

# Flo-Tronic Plus™

## User Manual



**Manual #: 011**

Initial Release: 12/21/2010

Rev No: 4

Date: 8/12/2016

**For assistance please contact:**

United Process Controls Inc.

TEL: +1 414 462 8200 • FAX: +1 414 462 7022

Toll-Free North America +1-800 438 3347

[waukee.support@group-upc.com](mailto:waukee.support@group-upc.com)

[www.group-upc.com](http://www.group-upc.com)

**COPYRIGHT**

No part of this publication may be reproduced, transmitted, transcribed, stored in a retrieval system, or translated into any language or computer language, in any form or by any means, electronic, mechanical, magnetic, optical, chemical, manual, or otherwise, without prior written permission of United Process Controls Inc..

**DISCLAIMER:**

The Flo-Tronic Plus™ is to be used by the industrial operator under his/her direction. United Process Controls is not responsible or liable for any product, process, damage or injury incurred while using the Flo-Tronic Plus™. United Process Controls Inc. makes no representations or warranties with respect to the contents hereof and specifically disclaim any implied warranties or merchantability or fitness for any particular purpose.

# TABLE OF CONTENTS

<b>WARNING</b> .....	<b>4</b>
<b>MANUAL OVERVIEW</b> .....	<b>5</b>
<b>FLOW SENSOR INTRODUCTION</b> .....	<b>6</b>
<b>SPECIFICATIONS</b> .....	<b>7</b>
<b>INSTALLATION AND WIRING</b> .....	<b>8</b>
<b>CALIBRATION AND FIELD SERVICE</b> .....	<b>11</b>
<b>MAINTENANCE</b> .....	<b>13</b>
<b>CALCULATIONS</b> .....	<b>14</b>
<b>TROUBLESHOOTING</b> .....	<b>15</b>
<b>APPENDIX “A” - DRAWINGS</b> .....	<b>16</b>

## WARNING

Thank you for purchasing control equipment from Waukee Engineering a member of United Process Controls. We want your new control equipment to operate safely. Anyone who uses this equipment should read this publication (and any other relevant publications) before installing or operating the equipment.

To minimize the risk of potential safety problems, you should follow all applicable local and national codes that regulate the installation and operation of your equipment. These codes vary from area to area and usually change with time. It is your responsibility to determine which codes should be followed, and to verify that the equipment, installation, and operation are in compliance with the latest version of these codes.

At a minimum, you should follow all applicable sections of the National Fire Code, National Electrical Code, and codes of the National Electrical Manufacture's Association (NEMA). There may be local regulatory or government offices that can also help determine which codes and standards are necessary for safe installation and operation.

Equipment damage or serious injury to personnel can result from failure to follow all applicable codes and standards. We do not guarantee the products described in this publication are suitable for your particular application, nor do we assume any responsibility for you product design, installation, or operation.

If you have any questions concerning the installation or operation of this equipment, or if you need additional information, please call us at 414-462-8200.



**WARNING: Read this manual thoroughly before using Flo-Tronic.**



**WARNING: This unit contains ESD (Electrostatic Discharge) sensitive parts and assemblies. Static control precautions are required when installing, testing, servicing or repairing this assembly. Component damage may result if ESD control procedures are not followed. If you are not familiar with static control procedures refer to an applicable ESD protection handbook.**



**WARNING: Flo-Meter must be earth grounded. Ungrounded Flo-Meters may become a source of Ignition.**

# MANUAL OVERVIEW

## The Purpose of this Manual

Thank You for Purchasing a Flo-Tronic Plus™ Flow Sensor. This manual shows you how to install, wire and maintain Waukee's Flo-Tronic Plus. It also helps you understand how to interface it to other devices in a control system. This manual contains important information and should be read and understood by all individuals who install, use or service this equipment.

## Supplemental Manuals

The Installation and Operation of UPC Flo-Meters manual contain technical information as well as precautions about Waukee Flo-Meters.

## Technical Support

We strive to make our manuals the best in the industry. We rely on your feedback to let us know if we are reaching our goal. If you cannot find the solution to your particular application, or, if for any reason you need technical assistance, please call us at:

**+1-414-462-8200 Toll free North America: +1-800-438-3347**

Our technical support group will work with you to answer your questions. They are available Monday through Friday from 8:00 A.M. to 4:30 P.M. Central Standard Time. We also encourage you to visit our web site where you can find technical and non-technical information about our products and company.

<http://www.group-upc.com>

If you have a comment, question or suggestion about any of our products, services, or manuals, please e-mail or contact us by phone.

## Conventions Used



When you see the exclamation point icon in the left-hand margin, the paragraph to its immediate right will be a warning. This information could prevent injury, loss of property, or even death in extreme cases. Any warning in this manual should be regarded as critical information that should be read in its entirety. The word **WARNING** or **CAUTION** in boldface will mark the beginning of the text.



When you see the "notepad" icon in the left-hand margin, the paragraph to its immediate right will be a special note.

# FLOW SENSOR INTRODUCTION

The Waukee Flo-Tronic™ utilizes a sensor to read the position of the float rod indicator on a Waukee Flo-Meter™. The unit provides both electrical and mechanical indication of flow. The unit is factory calibrated to provide linear and accurate flow measurement. If necessary, the Flo-Tronic may be “field calibrated”.

## How it works

Magnet assembly attached to float rod of the Waukee Flo-Meter interacts with a magnetostrictive linear position sensor installed in Flo-Meter sensing head. A strain pulse is induced in a specially designed waveguide by the momentary interaction of two magnetic fields. One field comes from a moving magnet, which passes along the outside of the sensing tube, the other field from a current pulse launched along a wire inside the waveguide. The interaction between these two magnetic fields produces a strain pulse which travels at sonic speed along the waveguide, until the pulse is detected at the head of the transducer. The position of the moving magnet is precisely determined by measuring the elapsed time between the launching of the electronic pulse and the arrival of the strain pulse. As a result, accurate non-contact sensing of the Flo-Meter’s indicator is achieved. The indicator position is directly related to the Flo-Meter’s flow rate and is represented by a proportional analog electrical signal.

## Model Explanation

FT M17

**Size**

- S17: S Gas (3" Scale)
- SF17: SF Liquid (3" Scale)
- M17: M1-7 (6" Scale)
- M811: M8-11 (6" Scale)
- L13: L1-3 (9" Scale)
- L46: L4-6 (9" Scale)
- L79: L7-9 (9" Scale)
- L10: L10 (9" Scale)

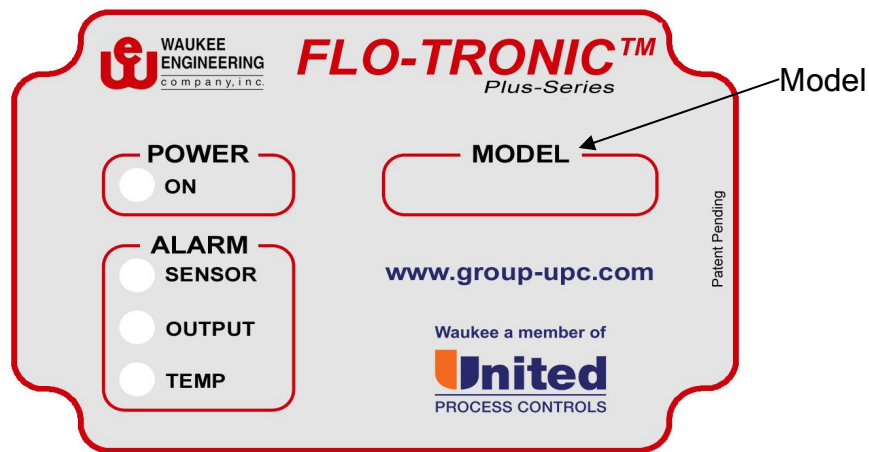

## SPECIFICATIONS

General Specifications		
Operation Specification		
Measurement	Accuracy	$\pm 0.4\% \text{ FS} + 1.6\% \text{ Rd}$
	Repeatability	$< 0.5\% \text{ FS}$
	Turndown Ratio	1:40 (2.5 ... 100%)
Electrical Power	Operating Voltage	24VDC $\pm 10\%$
	Power Consumption	75mA
Analog Output	Ranges Selectable	Current: 4-20mA or 0-20mA Voltage: 0-10VDC or 2-10VDC
	<b>Voltage Output</b>	
	Short Circuit Protection	YES
	Short Circuit Current	0.875mA
	Min Load Impedance	1k Ohm
	<b>Current Output</b>	
	Open Circuit Voltage	24VDC
	Max Load Impedance	500 Ohm
Relay Output	Type	SPST
	Contact Rating	0.5A @ 30VDC
	Alarm Logic	No power or alarm condition de-energize relay
Environment	Operating Temp	0°C to 65°C (32°F to 150°F)
	Humidity	20 to 90% RH (non-condensing)
	Storage Temp	-20°C to 65°C (-4°F to 150°F)
	Enclosure Rating	IP 65
	Installation Location	Keep from corrosive gas and liquid

# INSTALLATION AND WIRING

## Flo-Meter Installation

The Installation and Operation of Waukee Flo-Meters manual contains instructions on the proper installation of the Flo-Meter. Read all CAUTIONS and WARNINGS before proceeding.

The Flo-Tronic -Meter is shipped as a complete unit. Before installing the Flo-Meter, carefully remove the Flo-Tronic Sensor, to achieve this lay the unit on its side on a work bench or table. Then hold the Flo-Tronic unit with one hand, while unscrewing the union nut counters clockwise with the other hand to loosen it.



**CAUTION:** Once the Flo-Tronic is loose from the Flo-Meter make sure to pull the Flo-Tronic from the Flo-Meter straight back off the float rod assembly. Moving the Flo-Tronic to one side or another during removal may result in damage to the float rod assembly.

Remove the Float Rod Assembly and store it in a safe location until Flo-Meter body is installed and mounted. Once the Flo-Meter is installed, remove the red tape from the float rod and insert the float rod assembly into the Flo-Meter body. Fill the sight glass tube with Waukee Flo-Meter oil so that the level of oil is approximately one (1) inch from the top. Then carefully install the Flo-Tronic on to the Flo-Meter.



Do not put oil in the sight glass tube of meters used for **oxygen** or **methanol** service. Oxygen Flo-Meters should be run dry, or with distilled water. Flo-Meters for Methanol service will automatically fill the sight glass tube with Methanol when in service.



**WARNING:** Do not fill the sight glass tube with Flo-Meter oil on meters used for oxygen service. Use of oil may cause fire or explosion. Serious personal injury may result from fire or explosion.

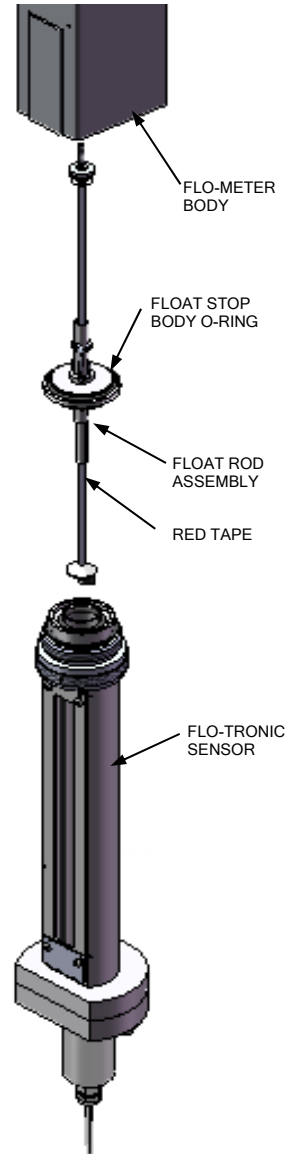



## Wiring Guidelines

Your company may have guidelines for wiring installation. If so, you should check those before you begin the installation. Here are some general things to consider:

- Use the shortest wiring route whenever possible.
- Use shielded wiring for all signal wiring and ground the shield at the Field Device end. **DO NOT** ground the shield at both the Flo-Tronic Sensor and Field Device.
- Do not run the signal wiring next to large motors, high current switches, or transformers. This may cause noise problems.
- Route the wiring through an approved cable housing to minimize the risk of accidental damage. Check local and national codes to choose the correct method for your application.
- Be sure to leave enough slack in the cables to allow easy removal of the Flo-Tronic from the Flo-Meter for maintenance. If seal tight or similar conduit is used, be sure to provide an adequate loop of conduit for maintenance access.

## Wiring Connections

All wiring connections are located inside the main box. To access the wiring terminals remove the (4) four screws located on the front of the box and remove the cover.



**CAUTION:** To reduce the risk of electrical shock and also to prevent damage to the Flo-Tronic and the Field Device. It is advised to turn off the supply power to the Flo-Tronic and Field Device before connecting or disconnecting any wires.



**WARNING:** Any electrical or mechanical modification to this equipment without prior written consent of United Process Controls will void all warranties, may result in a safety hazard, and may void the CE listing.



Use 18-22AWG shielded cable for the signal wiring. It is recommended to run all signal wires in a separate steel conduit. The shield wire should only be connected at the Field Device end. Do not connect shield wire on both ends.

## Circuit Protection

The Flo-Tronic is equipped with built-in over-voltage and short circuit protection. The unit may require recycling of power to reset once the fault condition is removed.

## Wiring Terminals

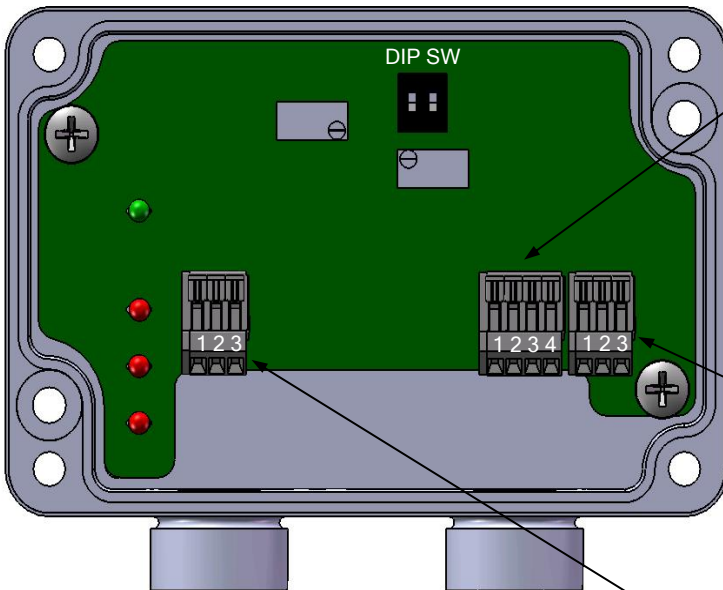

Power / Analog Output Wiring (4 Pin Terminal Block)		
Pin #	Description	Wire Color
1	+24VDC	Red
2	DC Common	Black
3	Analog Output (+)	Green
4	Analog Output (-)	White

Alarm Relay Wiring (3 Pin Terminal Block)		
Pin #	Description	Wire Color
1	Common	Brown
2	N.C.	Blue
3	N.O.	Orange

Sensor Wiring (3 Pin Terminal Block)		
Pin #	Description	Wire Color
1	+VDC	Brown
2	Signal Input	Green
3	Common	White

## Analog Output Configuration

Use the table below to configure the unit to the desired analog

DIP Switch Settings		
Switch A	Switch B	Analog Output
OFF	OFF	4-20mA
OFF	ON	2-10VDC
ON	OFF	0-20mA
ON	ON	0-10VDC

## Basic Wiring Diagram

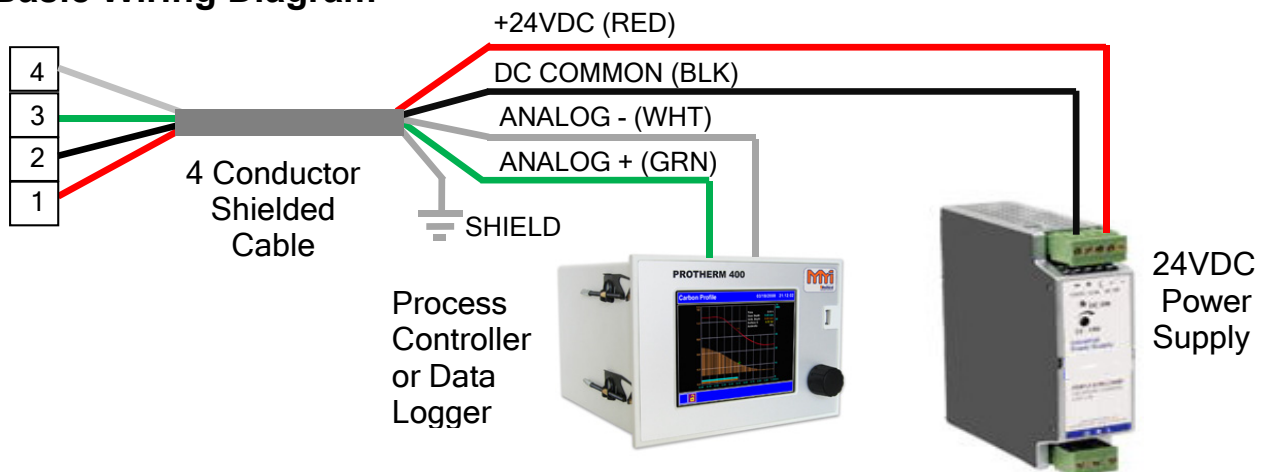

## Alarm Relay Wiring

The Flo-Tronic Plus includes an alarm relay, on power up the relay is energized to indicate that the unit has power. The relay will de-energize under the following alarm conditions:

- Loss of Power
- Loss of Sensor Signal
- Over Temperature Condition
- Output Wiring Problem



**CAUTION: Relay is for use with 30VDC or less ONLY!!! Use of any other voltage may result in damage to unit and poses a potential fire risk.**



**WARNING: An external relay must be used if connecting alarm contacts to a load over 0.5 Amps. Use of alarm contact with loads over 0.5 Amps will result in relay failure and poses a potential risk of fire.**

## CALIBRATION AND FIELD SERVICE

The Flo-Tronic Plus output signal is calibrated at the factory and should be received calibrated, but in some cases the unit may require field calibration of the electronics. If you find that the analog output signal is not correct in relation to the indicated flow, you can recalibrate the output by the adjustment of the “Zero” and “Span” potentiometers located inside the sensor box.



**CAUTION: Do not turn potentiometers excessively as these adjustments are sensitive.**

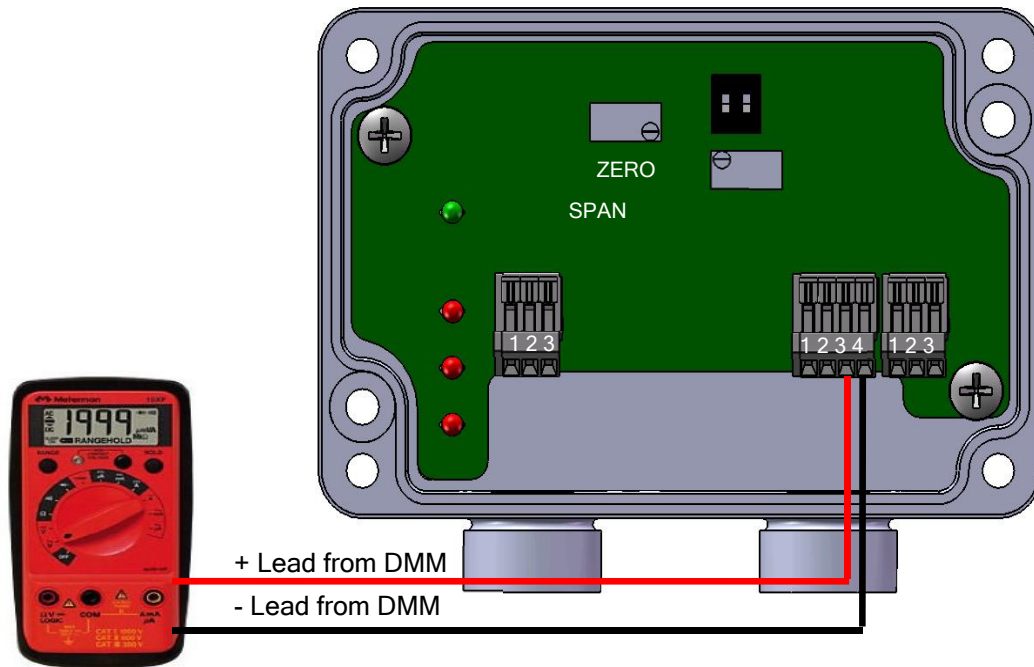

## Measurement of Output Signal

The best way to measure the output signal is to disconnect the unit from the field device and connect a multi-meter across terminals 3&4. Set the multi-meter to measure the correct signal the unit is setup for.



If you are unsure what the output signal is, refer to “Analog output configuration” located on page 8.

## Adjustment of Output Signal

This procedure requires the ability to move the float rod from 0 “Zero” flow to 100% “Full Scale” flow. There are two methods to achieve this.

### **Method 1**

Remove the Flo-Tronic and float rod assembly from the Flo-Meter and manually move the float rod assembly to the required position for calibration. Refer to page

6 of this manual for removal and installation. This is the preferred method of Calibration of the Flo-Tronic.



**CAUTION: Make sure supply fluid to Flo-Meter has been SHUT-OFF before removing the Flo-Tronic from the Flo-Meter. Failure to do so may result in accidental death or explosion.**

### **Method 2**

If the equipment and process allows this, the float rod assembly can be moved to the required position for calibration by shutting off the fluid valve for zero flow and opening the fluid valve to full open for full flow.



**WARNING: Depleting or over-gassing of equipment that the Flo-Meter is connected to may produce a hazardous condition, check with all personnel before attempting this method of calibration. Waukee is not responsible for any damages that may occur using this method.**

To adjust the Zero (0%), the float rod should be at the bottom or zero flow position. Then adjust the “Zero” pot until the signal is correct for the selected analog output. This will be 4mA for 4-20mA, 0mA for 0-20mA, 2V for 2-10VDC and 0V for 0-10VDC

To adjust the Span “Full Scale Flow”, the float rod will now need to be adjusted to Full scale (100%). Then adjust the “Span” pot until the signal is correct for the selected analog output. This will be 20mA for a current output or 10VDC for a voltage output.

## **MAINTENANCE**

The Flo-Tronic is a magnetic based sensor which is unaffected by dirt. The dampening oil can be soiled to the point that it is not possible to visually read the flow on the Flo-Meter and the unit will still accurately determine the position of the float rod assembly.

The Flo-Meter is a mechanical device that requires regular maintenance in order to maintain accuracy. All Flow Meters are susceptible to dirt affecting its accuracy. Although not all manufactures have a means to gauge when the Flo-Meter requires maintenance. Waukee Flo-Meters on the other hand have a built in indication when the Flo-Meter requires maintenance, which is the dampening oil. When the oil becomes soiled it is indication maintenance on the Flo-Meter is needed. The frequency of maintenance intervals will vary depending on the cleanliness of the gas being used. To replace the oil will require the removal of the Flo-Tronic; refer to the installation section of this manual for instructions. Also during these maintenance intervals it is recommended that all

gaskets and o-rings are inspected for signs of wear or damage. Replace worn or damaged seals. Gasket kit sets are available from Waukee if needed.

## CALCULATIONS

### Determine output for a given flow rate

1. First determine the % of scale represented by:

$$\% \text{ of Scale} = \frac{\text{Actual Flow (cfh)}}{\text{Full Scale Flow (cfh)}}$$

2. Then the Output is calculated by:

$$\text{For 4-20mA } \text{mA} = (\% \text{ of Scale} \times 16) + 4$$

$$\text{For 0-20mA } \text{mA} = \% \text{ of Scale} \times 20$$

$$\text{For 2-10VDC } \text{VDC} = (\% \text{ of Scale} \times 8) + 2$$

$$\text{For 0-10VDC } \text{VDC} = \% \text{ of Scale} \times 10$$

#### Example 1:

Scale Plate is 750CFH  
Indicated Flow is 500CFH  
Output range = 4-20mA

$$\frac{500}{750} = .6666$$

$$(.6666 \times 16) + 4 = 14.65\text{mA}$$

### Determine the flow rate from the output

1. First determine % of Full Scale:

$$4\text{-}20\text{mA Range} = \frac{\text{mA} - 4}{16}$$

$$0\text{-}20\text{mA Range} = \frac{\text{mA}}{20}$$

$$0\text{-}10\text{VDC Range} = \frac{\text{VDC}}{10}$$

$$2\text{-}10\text{VDC Range} = \frac{\text{VDC} - 2}{8}$$

2. Then Actual Flow is calculated by:

$$\text{Actual Flow} = \% \text{ of Full Scale} \times \text{Full Scale Flow}$$

#### Example 2:

Find the flow rate for a 4-20mA signal of 12.00mA and a Flow Meter Scale of 1000CFH

$$\frac{12 - 4}{16} = .5 \text{ or } 50\%$$

$$.5 \times 1000 = 500\text{CFH}$$

## TROUBLESHOOTING

### Diagnostic Lights

The Flo-Tronic has a comprehensive diagnostic system. The diagnostic lights are displayed on the front panel of the unit.

**PWR** - The Power LED indicates when power is applied.

**SEN** - The Sensor LED indicates when Sensor Signal is Lost

**OUT** – The Output LED indicates when there is a problem with the output signal  
 Current mode = Output Open (No Load) or load resistance too high  
 Voltage mode = Output shorted or input resistance too low

**TEMP** – The TEMP LED indicates when unit electronics (IC) temperature is in excess of 185°F; unit will not function until temperature is below 185°F

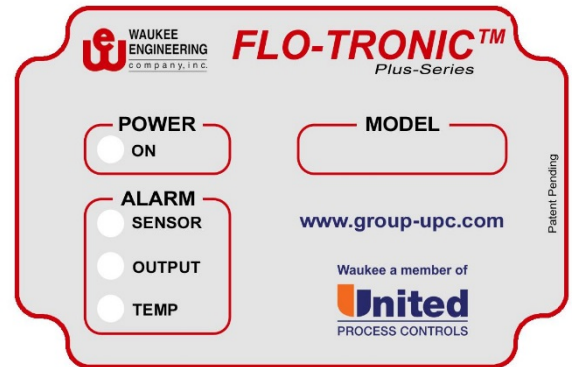

Diagnostics	
Description	Corrective Actions
PWR LED not Illuminated	<ol style="list-style-type: none"> <li>1. Check for 24VDC power at terminals 1 and 2</li> <li>2. Make sure power supply is not over loaded</li> </ol>
SENSOR LED Illuminated	<ol style="list-style-type: none"> <li>1. Check wiring at terminals 1,2,3 of sensor TB</li> <li>2. Check for cut or damaged sensor cable</li> </ol>
OUTPUT LED Illuminated	<ol style="list-style-type: none"> <li>1. Check wiring at terminals 3 &amp; 4</li> <li>2. Check wiring at Field device</li> <li>3. Ensure unit is configured for correct output signal</li> </ol>
TEMP LED Illuminated	<ol style="list-style-type: none"> <li>1. Shield device from sources of heat</li> </ol>

# **APPENDIX “A” - DRAWINGS**

On Demand



---

Reach us at [www.group-upc.com](http://www.group-upc.com)

United Process Controls brings together leading brands to the heat treating industry including Waukee Engineering, Furnace Control, Marathon Monitors and Process-Electronic.

We provide prime control solutions through our worldwide sales and services network with easy-to-access local support.

**UNITED PROCESS CONTROLS INC.**  
5600 W. Florist Avenue, Milwaukee, WI 53218 USA

Phone: +1-414-462-8200 Fax: +1-414-462-7022  
Toll-Free North America +1-800-438-3347  
E-mail: [waukee.sales@group-upc.com](mailto:waukee.sales@group-upc.com)

