

Versapro Carbon / Dewpoint Monitor / Controller

Installation and Operation Handbook



Manual #: 020

Part # F200061

Revision 0.00	October 1, 2003	
Revision 0.01	December 8, 2004	
Revision 0.02	March 28, 2005	(Firmware revision 1.11)
Revision 0.03	September 2, 2005	(Firmware revision 1.13)
Revision 0.04	November 30, 2005	(Firmware revision 1.13 and higher)
Revision 0.05	February 6, 2006	(Firmware revision 1.15 and higher)
Revision 0.06	May 18, 2006	(Firmware revision 1.19 or 2.19 and higher)
Revision 0.07	May 21, 2006	(Firmware revision 1.19 or 2.19 and higher)
Revision 0.08	July 19, 2006	(Firmware revision 1.20 or 2.20 and higher)
Revision 0.09	April 19, 2007	(Firmware revision 1.22 or 2.22 and higher)
Revision 0.10	December 7, 2007	(Firmware revision 1.25 or 2.25 and higher)
Revision 0.11	June 27, 2008	(Firmware revision 1.26 or 2.26 and higher)
Revision 0.12	August 11, 2008	(Firmware revision 1.26 or 2.26 and higher)
Revision 0.13	September 3, 2008	(Firmware revision 1.26 or 2.26 and higher)
Revision 0.14	April 27, 2009	(Firmware revision 1.26 or 2.26 and higher)
Revision 0.15	October 15, 2009	(Firmware revision 2.27 and higher)
Revision 0.16	October 6, 2011	(Firmware revision 2.32 and higher)
Revision 0.17	March 20, 2013	(Firmware revision 2.35 and higher)
Revision 0.18	October 30, 2013	(Firmware revision 2.35 and higher)
Revision 0.19	February 24, 2015	(Firmware revision 2.38 and higher)
Revision 0.20	May 1, 2015	(Firmware revision 2.39 and higher)

All trademarks used in this publication are duly marked and the sole property of their respective owners. No attempt at trademark or copyright infringement is intended or implied.

Modbus is a registered trademark of MODICON, INC.

COPYRIGHT

No part of this publication may be reproduced, transmitted, transcribed, stored in a retrieval system, or translated into any language or computer language, in any form or by any means, electronic, mechanical, magnetic, optical, chemical, manual, or otherwise, without prior written permission of United Process Controls Inc.

DISCLAIMER

United Process Controls makes no warranties express or implied beyond the written warranty presented at initial purchase. United Process Controls Inc. is not responsible for any product, process, damage or injury incurred while using this equipment. United Process Controls makes no representations or warranties with respect to the contents hereof and specifically disclaims any warranties of merchantability or fitness for any particular application or purpose.

For assistance please contact:

United Process Controls Inc.

TEL: +1 513 772 1000 • FAX: +1 513 326 7090

Toll-Free North America +1-800-547-1055

upc.support@group-upc.com

www.group-upc.com

Table of Contents

SAFETY AND ENVIRONMENT INFORMATION	5
SERVICE AND REPAIR.....	5
INSTALLATION SAFETY REQUIREMENTS.....	5
SAFETY SYMBOL.....	5
PERSONNEL.....	5
ENCLOSURE OF LIVE PARTS	5
LIVE SENSORS	6
WIRING.....	6
POWER ISOLATION.....	6
EARTH LEAKAGE CURRENT	6
OVER CURRENT PROTECTION.....	6
VOLTAGE RATING.....	6
CONDUCTIVE POLLUTION	7
OVER-TEMPERATURE PROTECTION.....	7
GROUNDING OF THE TEMPERATURE SENSOR SHIELD	8
INSTALLATION REQUIREMENTS FOR EMC	8
ROUTING OF WIRES	8
VERSAPRO FEATURES.....	8
INSTALLATION.....	9
MOUNTING.....	10
PROCESS CONTROL OPTIONS.....	11
CONTROL MODES.....	11
TIME PROPORTIONING (TP).....	12
TIME PROPORTIONING DUAL (TD)	12
TIME PROPORTIONING WITH COMPLEMENT (TC)	12
POSITION PROPORTIONING (PP)	12
ON/OFF (OF).....	13
ON/OFF DUAL (OD).....	13
ON/OFF WITH COMPLEMENT (OC).....	13
DIRECT CURRENT OUTPUT.....	13
DIRECT OR REVERSE CONTROL ACTION.....	14
ANALOG OUTPUT CHANNELS	14
ALARMS	15
PROCESS ALARMS.....	16
OFF.....	16
Full Scale HI.....	16
Full Scale LO.....	17
Deviation Band.....	17
Deviation High.....	17
Deviation Low	17
Output High.....	17
Output Low.....	17
Fault.....	17
Probe.....	17
Time.....	17
Start.....	18
Soak.....	18
ALARM ACTION	18

ALARM DELAY TIMES	18
DIAGNOSTIC ALARMS.....	19
SERIAL INTERFACE.....	19
FRONT PANEL OPERATION.....	20
ENTER KEY.....	21
REMOTE KEY.....	22
SETPY KEY.....	22
SETUP KEY.....	23
DUAL KEY FUNCTIONS.....	33
<i>Starting / Stopping Probe Tests</i>	34
<i>Start Timer</i>	34
<i>Edit Timer</i>	34
<i>Monitor Mode</i>	34
DIGITAL INPUT EVENT	34
OFF.....	35
PROB.....	35
<i>AUTO (controller only)</i>	35
<i>rEn (controller only)</i>	35
ACK.....	35
<i>PrOC (controller only)</i>	35
<i>Strt (controller only)</i>	35
<i>HOLd (controller only)</i>	36
<i>End (controller only)</i>	36
TIMER FUNCTION.....	36
SETTING THE TIMER.....	36
TIME.....	37
GUARANTEED START TIMER.....	37
GUARANTEED SOAK TIMER.....	38
TIMER ALARM BEHAVIOR.....	39
TIMER STATE DIAGRAM.....	39
TIMER SIO OPERATIONS.....	41
CONTROLLING THE TIMER REMOTELY.....	42
SENSOR IMPEDANCE TEST.....	43
WHY MEASURE SENSOR IMPEDANCE?	44
SENSOR BURNOFF.....	45
PROCEDURE TO TEST THE SENSOR	46
TUNING.....	47
WHAT IS TUNING?.....	47
SCALING ANALOG INPUTS.....	50
LINEAR A EXAMPLE	50
SCALING ANALOG OUTPUTS.....	50
CALIBRATION	51
CALIBRATION DISPLAYS AND KEYBOARD OPERATION.....	52
PREPARING FOR INPUT CALIBRATION	52
<i>Calibration of Temperature and Cold Junction</i>	53
<i>Calibration of the Thermocouple Input (linear mode)</i>	55
<i>Calibration of the Probe Millivolt Input</i>	55

PREPARING FOR ANALOG OUTPUT CALIBRATION	55
COMMUNICATIONS.....	56
MODBUS	56
<i>RTU Framing</i>	57
<i>Address Field</i>	57
<i>Function Field</i>	57
<i>Data Field</i>	58
<i>Error Check Field (CRC)</i>	58
MMI MESSAGE PROTOCOL.....	59
INSTRUMENT TYPE 'U' COMMAND SET.....	61
<i>'X' Command</i>	62
<i>Block Commands</i>	64
<i>MMI Error Codes</i>	66
PROCESS CALCULATION	66
PERCENT CARBON	66
DEW POINT.....	68
TROUBLESHOOTING QUESTIONS.....	69
ANALOG INPUTS.....	69
CONTROL OUTPUTS.....	70
DIGITAL COMMUNICATIONS	70
DISPLAY FUNCTIONS	70
PROBE CARE	71
TIMER FUNCTION	71
TECHNICAL SPECIFICATION.....	73
ENVIRONMENTAL RATINGS.....	73
EQUIPMENT RATINGS	73
GENERAL.....	73
VERSAPRO MEMORY MAP.....	75
VERSAPRO SETUP SHEET.....	88

Safety and Environment Information

Please read this section carefully before installing the controller

This instrument is intended for industrial applications used in conjunction with United Process Controls zirconia carbon sensors and standard thermocouple types. It is assumed that any installation meets either CE standards for industrial safety or NEC standard wiring practices. Failure to observe these standards or the installation instructions in this manual may degrade the safety or electrical noise protection provided by this instrument. It is the installer's responsibility to ensure the safety and electrical noise compatibility of any installation.

Service and repair

This controller has user replaceable fuses but no other user serviceable parts. Contact your Marathon Sensors Service (800-547-1055) for repair.

Caution: Charged capacitors

Before removing an instrument from its case, disconnect the supply and wait at least two minutes to allow capacitors to discharge. Failure to observe this precaution will expose capacitors that may be charged with hazardous voltages. In any case, avoid touching the exposed electronics of an instrument when withdrawing it from the case.

Electrostatic Discharge (ESD) Precautions

When the controller is removed from its case, some of the exposed electronic components are vulnerable to damage by electrostatic discharge. Anyone who is not probably ground using an ESD wrist strap or in contact with a ground while handling the controller may damage exposed electronic components.

Installation Safety Requirements

Safety Symbol

Various symbols are used on the instrument, they have the following meaning:

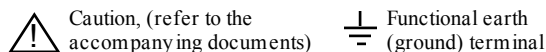

The functional earth connection is required for safety ground add to ground RFI filters.

Personnel

Installation must be carried out by qualified personnel.

Enclosure of live parts

To prevent hands or metal tools touching parts that may be electrically live, the controller should be installed in an enclosure. The contacts on the rear of the instrument case or finger save but it is still possible for loose wiring, or metal objects to come in contact with live terminal connections. It is recommended that power be removed from the instrument connections before they are disconnected. However,

instrument's power connector can be removed with power applied. Care should be taken that the connector does not come in contact with any grounded object.

Live sensors

The dc inputs, dc logic, and dc outputs are all electrically isolated from chassis ground. If the temperature sensor is connected directly to an electrical heating element then the inputs will also be live. The controller is designed to operate under these conditions. However you must ensure that this will not damage other equipment connected to these inputs and that service personnel do not touch connections to these terminals while they are live. With a live sensor, all cables, connectors and switches for connecting the sensor and non-isolated inputs and outputs must be mains rated.

Wiring

It is important to connect the controller in accordance with the wiring data given in this handbook. Take particular care not to connect AC supplies to the low voltage sensor input or other low level inputs and outputs. Only use copper conductors for connections (except thermocouple inputs) and ensure that the wiring for installations comply with all local wiring regulations. For example, in the UK, use the latest version of the wiring regulations, BS7671. In the USA use NEC Class 1 wiring methods.

Power Isolation

The installation must include a power isolating switch or circuit breaker. This device should be in close proximity to the control actuator, and within easy reach of the operator. There is no means of disconnecting power from the instrument other than removing the connectors from the rear of the instrument. It is recommended that additional power disconnects are provided in the installation to remove power from these connectors as well.

Earth leakage current

Due to RFI Filtering there is an earth leakage current of less than 0.5mA. This may affect the design of an installation of multiple controllers protected by Residual Current Device, (RCD) or Ground Fault Detector, (GFD) type circuit breakers.

Over Current protection

The instrument has an internal 3.15 Amp fuse (P/N MFU-3.15PCTT) for instrument power and 1 Amp fuses (P/N MFU-1.0PCTT) for the control contacts and alarms. It is recommended that additional protection against excess currents be used for loads exceeding this rating. Fusing and interposing relays should be added to the control circuit if high current or large inductive loads are used.

Voltage rating

The maximum continuous voltage applied between any of the following terminals must not exceed 250VAC:

- line or neutral to any other connection;

- relay output to logic, dc or sensor connections;
- any connection to ground.

The controller should not be wired to a three phase supply with an unearthed star connection. Under fault conditions in this supply could rise above 264VAC with respect to ground and the product would not be safe.

Voltage transients across the power supply connections, and between the power supply and ground, must not exceed 2.5kV. Where occasional voltage transients over 2.5kV are expected or measured, the power installation to both the instrument supply and load circuits should include a transient limiting device.

These units will typically include gas discharge tubes, metal oxide varistors, and constant voltage transformers help suppress voltage transients on the supply line due to lightning strikes or inductive load switching. Devices are available in a range of energy ratings and should be selected to suit conditions at the installation.

Conductive pollution

Electrically conductive pollution must be excluded from the cabinet in which the controller is mounted. For example, carbon dust is a form of electrically conductive pollution. To secure a suitable atmosphere in conditions of conductive pollution, fit an air filter to the air intake of the cabinet. Where condensation is likely, for example at low temperatures, include a thermostatically controlled heater in the cabinet.

Over-temperature protection

When designing any control system it is essential to consider what will happen if any part of the system should fail. In temperature control applications the primary danger is that the heating will remain constantly on. Apart from scrapping the product, this could damage any process machinery being controlled, or even cause a fire.

Reasons why the heating might remain constantly on include:

- The temperature sensor becoming detached from the process;
- Thermocouple wiring becoming a short circuit;
- The controller failing with its heating output constantly on;
- An external valve or contactor sticking in the heating condition;
- The controller setpoint set too high.

Where damage or injury is possible, we recommend fitting a separate over-temperature protection unit. Factory Mutual requires that any over temperature device use an independent temperature sensor, which will isolate the heating circuit.

Please note that the alarm relays within the controller will not give protection under all failure conditions. This instrument is not suited for over temperature protection and should not be used as a safety device.

Grounding of the temperature sensor shield

In some installations it is common practice to replace the temperature sensor while the controller is still powered up. Under these conditions, as additional protection against electric shock, we recommend that the shield of the temperature sensor be grounded at one end of the wire. Do not rely on grounding through the framework of the machine.

Installation requirements for EMC

To ensure compliance with European EMC directives certain installation precautions are necessary as follows:

- When using relay outputs it may be necessary to fit a filter suitable for suppressing the emissions. The filter requirements will depend on the type of load. For typical applications such as Schaffner FN321 or FN612 line filters or equivalents.
- If the unit is used in table top equipment which is plugged into a standard power socket, it is likely that compliance to the commercial and light industrial emissions standard is required. In this case, to meet the conducted emissions requirement, a suitable mains filter should be installed. Recommended filters would be Schaffner types FN321 and FN612 or equivalents.

Routing of wires

To minimize the pick-up of electrical noise, the wiring for low voltage dc and particularly the sensor input should be routed away from high-current power cables. Where it is impractical to do this, use shielded cables with the shield grounded at one end.

VersaPro Features

The VersaPro is a single loop process non programmable controller / monitor with the following capabilities:

Both Controller and Monitor

- Two channel 24 bit Sigma-Delta ADC for thermocouple, probe millivolt, with cold junction compensation.
- Two (2) Form A control contacts.
- Two (2) Form A alarm contacts.
- Internal relay for zirconia sensor burnoff.
- Internal relay for zirconia sensor impedance testing.
- Serial EEPROM stores setup and calibration values.
- Two (2) 4-20 milliamp outputs for control or chart recorder.
- One digital event input (dry contact only).
- Sixteen character LCD with two four digit LED segment displays.
- RS 485 serial communication port for either MMI protocol or Modus.
- Timer function

Controller only

- Two (2) Form A control contacts.
- PID control mode.

Installation

The VersaPro instrument is designed for up to 1/8" panel mounting in a DIN standard opening of 3.62" square (adapter panels available by special order). Required rear clearance is 7.5" to allow for wiring.

As with all solid state equipment, the controller should be located away from excessive heat, humidity, and vibration. Since the unit uses LED and LCD display devices, it should also be located so that direct sunlight will not interfere with the display's visibility. The instrument requires 120/240 VAC 50/60 Hz and should not be on the same circuit with other noise-producing equipment such as induction machines, large electrical motors, etc. Signal wiring must be run separate from control wiring. It is suggested that signal wiring at the rear terminals of the instrument be routed in one direction (up or down) while the AC power wires are routed in the opposite direction.

The following figure shows the rear terminals locations on the rear of the VersaPro.

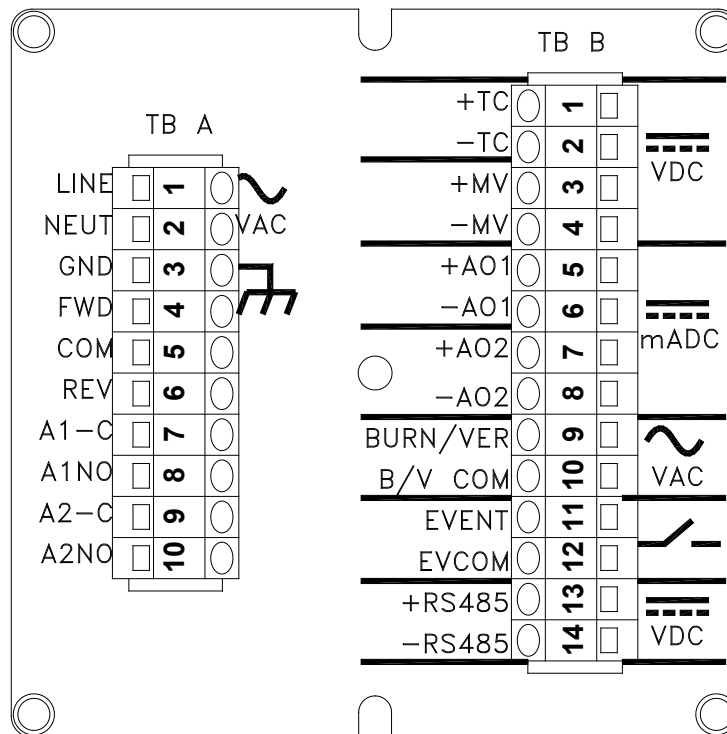

Figure 1 VersaPro Rear Panel

The next figure shows a typical wire schematic for the Versapro carbon controller.

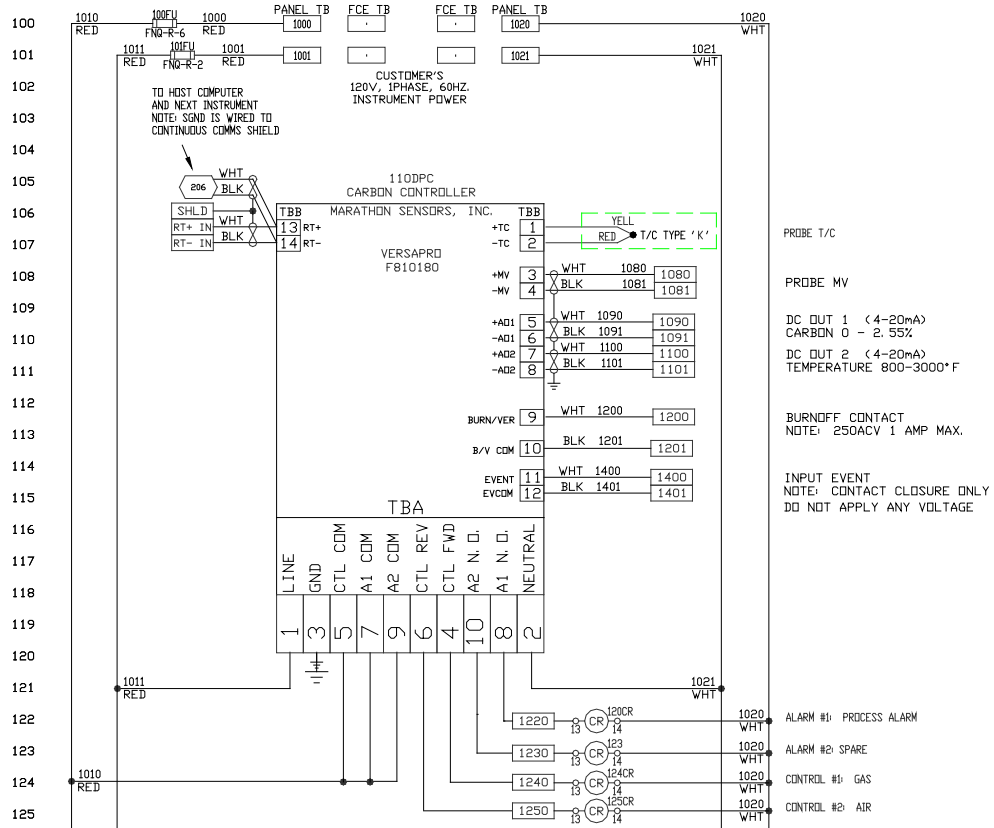

Figure 2 Typical Wiring Schematic

Mounting

To mount the instrument in a control panel, a hole must be cut 3.62" square in the necessary location on the panel. The following procedure should be followed to mount the VersaPro in the panel.

- 1) Insert the unit into previously cut out 3.62" square hole in panel.
- 2) While supporting unit, insert one clamping bracket into the groove on the bottom of unit, and then install the 6-32 set screw.
- 3) Repeat step 2 for the top of the unit.
- 4) With a HEX KEY wrench, alternately tighten the screw on either side of instrument to a torque of six in.-lbs. Insure rigidity of mounting. DO NOT OVER TIGHTEN. This can warp the instrument enclosure and make removal difficult.

To remove the instrument from the panel, reverse the above procedures.

Process Control Options

The Versapro can be configured to perform a number of specific control functions. The following table outlines the available process functions for the carbon controller / monitor.

Table 1 Instrument Control Options

Function	Description
Carbon	Uses the millivolt and temperature signals from a zirconia sensor to calculate carbon concentrations and controls to a carbon set point. Typically a direct process.
Dew point	Uses the millivolt and temperature signals from a zirconia sensor to calculate dew point and controls to a dew point set point. Typically a reverse process.
Linear Input A	Uses the millivolt signal from a linear sensor connected to terminals +TC / -TC
Linear Input B	Uses the millivolt signal from a linear sensor connected to terminals +MV / -MV

Control Modes

The VersaPro controller provides:

- Time Proportional Single (TP)
- Time Proportional Dual (TD)
- Time Proportional Compliment (TC)
- Position Proportioning (PP)
- On/Off (OF)
- On/Off Dual (OD)
- On/Off Compliment (OC)
- Direct Signal Output (4-20mA)

The instrument controls with two control contacts or direct 4-20mA output from two analog output channels. The control function can be set to direct acting or reverse acting.

Direct acting increases the output control signal to increase the process. Reverse acting decreases the output control signal to increase the process.

It is recommended that the HI and LOW Percent Output values are checked any time the control mode is changed. This insures that a negative LOPO value is selected for dual control modes.

Time Proportioning (TP)

Time proportioning adjusts the duty cycle of the control device to maintain control. This is usually done with solenoid valves controlling the flow of a trim gas or addition air to the process. The control loop percent output is the percentage of the ON time relative to total cycle time. The cycle time is the ON time plus OFF time.

For example if the control loop percent output is 34% and the cycle time is 10 seconds, then the ON time would be 3.4 seconds and the OFF time would be 6.6 seconds. The selection of the proper cycle time is a trade off between excess wear and tear on the solenoid valve with short cycle times or oscillation of the control process using long cycle times. Only the first control contact is used in this mode.

Time Proportioning Dual (TD)

This mode is used when there are two processes to control that have complementary effects; like gas and air. The time proportioning dual mode uses two control outputs; one for gas and one for air. There is never a time when both outputs are on simultaneously. The control loop computes a percent output from -100 to +100%. When positive, the proportioning action applies to the forward output (gas). When negative the proportioning action applies to the reverse (air) output.

Time Proportioning with Complement (TC)

This mode is identical to the time proportioning mode except that both control outputs are used. The second control output is the complement of the first. That is when the first output is ON then the second is OFF and vice versa. This mode is used with single action motorized valves that open quickly when a voltage is applied to one terminal and close quickly when voltage is applied to the other terminal.

Position Proportioning (PP)

This mode is used with motorized valves that do not have slidewire feedback. This mode is sometimes referred to as "bump" mode because it "bumps" the valve slightly more open or closed. This mode uses both control outputs; one to drive the motor forward (open) and the other to drive it reverse (closed). The control output is the difference between the new percent output and the last percent output. If the difference is positive then the valve motor is driven open for that percentage of the cycle. If negative it is driven closed by that percentage of the cycle time.

For example if the new percent out is 60% and the old was 45% then the motor is driven open for 15% of the cycle time. If the cycle time is set to the time that the motor takes to move to fully open, then the flow is theoretically increased by 15%. Two special cases exist. If the control output is computed at 100% then the motor is driven continuously in the open direction. Likewise, if the control output is computed as 0% then the motor is driven continuously closed. The HIPO is limited to a range of 0 to 100%. The minimum LOPO value is 0%.

There is a built in deadband for this control of 1% of control output difference. The control output is calculated to 0.1% of control but in PP mode only a full 1% of change will affect the control contacts. The PID values do have an affect on the

response time of the control output changes. High proportional band values should be used if the value is moving too quickly for the process.

ON/OFF (OF)

ON/OFF control is exactly what it implies, the control action is either ON or OFF. With true ON/OFF control the control output is ON whenever the process is below the setpoint value and OFF when the process is at or above the process value. In many real world applications this simple control method will cause "contact chatter" because of noisy signals which will switch the ON and OFF states rapidly. Also since the control action does not turn OFF until the setpoint is reached, the process will overshoot due to lags in the control action.

Marathon controllers incorporate two features that prevent these problems from occurring; hysteresis and deadband. Hysteresis provides a delay between the control on point and the off point. Noise will not cause the control output to "chatter" with this gap applied. Hysteresis is $\pm 20\%$ of the deadband value.

Deadband allows the process to deviate away from the setpoint by the width of the deadband before any control action occurs. The deadband is adjusted through the Proportional Band in units of the displayed setpoint value. The reset and rate values have no effect in ON/OFF control.

Let's assume the process setpoint is 1.00% carbon with a proportional band of 5. This represents a deadband of 0.05% carbon, which is a band of $\pm 0.05\%$ carbon around setpoint. The hysteresis is 0.01% of the setpoint or 20% of the deadband. The output is turned on when the process drops below 0.95% carbon and turns off then it reaches 0.99% carbon.

The deadband controls the point where the control is turned on to correct any deviation from set point. The hysteresis controls the point where the control is turned off to prevent overshoot or chatter.

ON/OFF Dual (OD)

This mode is similar to the time proportioning dual mode. The forward output acts as described in the ON/OFF description above. The reverse output responds when the process is above the setpoint.

Using the carbon example with a proportional band (deadband) of 5, the gas contact would turn on when the process is 0.95% carbon and will turn off when it comes to 0.99% carbon. Likewise the air contact would turn on when the process exceeds 1.05% carbon and will turn off when it drops to 1.01% carbon.

ON/OFF with Complement (OC)

This mode is exactly like ON/OFF control with the addition of a second control output. The second control contact is turned ON when the first is control contact is OFF and vice versa.

Direct Current Output

The Versapro has two analog output channels that provide an isolated 4 to 20mA signal proportional to selectable process values. The analog outputs can be configured to control the process by driving actuators with a 4-20mA signal proportional to the calculated percent output of the PID loop. One or both output channels can be used depending on the control mode selected. POUT selection drives the output signal based on the HIPO and LOPO settings. If a Dual Time Proportioning control mode is selected with a HIPO = 100 and a LOPO = -100 then the output will be 4mA for -100%, 12mA for 0%, and 20mA for +100% output. This setting is helpful if one actuator is driving two valves in a split configuration where air is fully opened at -100% and gas is fully opened at +100% or both are closed at 0%.

It is possible to drive two actuators independently by setting on output to PO1 or PO2 where PO1 is the 0 to +100% control output and PO2 is 0 to -100%. In this configuration both outputs are at the maximum ($\pm 100\%$) with an output of 20mA.

It is also possible to drive one actuator with an output channel and a solenoid with a control contact. For example, select PO1 for one analog output channel to drive a gas actuator and connect an air solenoid to the reverse control contact. The percent output for both functions is determined by the PID settings. The cycle time should be set to the stroke time required to fully open the actuator from a fully closed condition. Typical stroke times would be 30 to 45 seconds.

The control contacts will still act as described in the previous modes even if the analog output channels are being used.

Direct or Reverse Control Action

Control action determines how the output of the controller will react to effect a change on the process. The control action is considered 'direct' if an increase in the output produces an increase in the process value. A 'reverse' control action would be when an increase in the output produces a decrease in the process.

For example oxygen would require a reverse acting control if the process component the instrument is controlling is a trim gas. Increasing the trim gas will result in a decrease in the oxygen reading. It would be considered a direct acting control if the process component under control is additional air. Either process would use the first control contact, it would just be activated above or below the process set point depending on what is being added to the process.

Carbon is typically a direct acting control if control contact 1 is gas and control contact 2 is air. Increase the control 1 output (gas) will increase the carbon. In the same control scheme, dew point would require a reverse control action where the increase in gas would lower the dew point.

Analog Output Channels

The two analog output channels can also be set to retransmit selectable process values. The Analog Output Offset and Range can be set to correspond to the process range. The default settings for these channels is 0 – 2.55% carbon for channel 1 and 0 to 2000°F sensor temperature for channel 2.

The Versapro output channels can drive a chart recorder or PLC input. Each output channel has an internal current source and does not need an external power supply. The remote input should be configured for of 0 - 5 VDC or 4 - 20 mA. If the input device only responds to a DC voltage input, it will be necessary to add a 250 ohm dropping resistor across its input terminals and scale the analog output as 0 – 20mA.

The ideal location of the input device such as a recorder is adjacent to the instrument but it may be located remotely if the connecting wires are properly shielded. For best results, the chart recorder input(s) should be isolated from ground with the cable shield grounded on one end of the cable.

In the controller mode, the outputs can be configured drive a two separate valve actuators or a single actuator setup in a split configuration.

Alarms

The instrument has two types of alarms, process alarms and diagnostic alarms. If an alarm has been selected and conditions are such that the alarm becomes active, the instrument will display this condition on the center LCD display. Alarms can be configured as latched or non-latched and as direct or reverse.

A reverse configuration would be considered a failsafe setting since the alarm contact is closed during normal conditions and opens if power is removed to the instrument or the configured alarm condition occurs.

The alarm message will be displayed on the LCD screen with it occurs. If the LCD screen is written with another message all active alarms can be seen by pressing the up or down arrow keys.

The display cannot be cycled to other parameters such as temperature or probe millivolts if an alarm is active.

ALARM DISPLAY	CONDITION	ACTION
HIGH ALARM	Alarm contact assigned to FSHI, dUbd, bdHI, HIPO	Full Scale High, above Deviation Band, or above percent output setting. Contact automatically resets unless latched.
LOW ALARM	Alarm contact assigned to FSLO, dUbd, bdLO, LOPO	Full Scale Low or below Deviation Band, or below percent output setting. Contact automatically resets unless latched.
PROBE CARE FAULT	Alarm contact assigned to PrOb	Probe impedance high or probe recovery time exceeds limit. Contact resets monetarily unless latched.
TIMER END	Alarm contact assigned to TinE, Strt, SOAK	Timer end alarm when the timer counts to zero for Timer, Start, or Soak timer modes. The contact latches until reset by pressing the Enter key or through the Input

ALARM DISPLAY	CONDITION	ACTION
		Event.
LLLL	Display only	Displays process value is negative and exceeds display range or exponent setting
HHHH	Display only	Displays process value is positive and exceeds display range or exponent setting
FLASH CSUM	Alarm contact assigned FALt	Reset instrument power. Return to Marathon if error does not clear.
EEPROM CSUM	Alarm contact assigned FALt	Reset instrument power. Return to Marathon if error does not clear.
KEYBOARD	Alarm contact assigned FALt	Reset instrument power. Do not push any keys while instrument is powered on. Return to Marathon if error does not clear.
FLASH ERASE	Alarm contact assigned FALt	Programming error, Reset instrument power, attempt reload.
FLASH / EE SIZE	Alarm contact assigned FALt	Programming error, Reset instrument power, attempt reload.
TEMP OPEN	Alarm contact assigned FALt	Check thermocouple for open condition or loose connection.
MV OPEN	Alarm contact assigned FALt	Check probe millivolt signal for open condition or loose connection. This signal can only be tested if the probe temperature is above 1300°F and exposed to process gas.
CPU FAULT	Alarm contact assigned FALt	Reset instrument power. Return to Marathon if error does not clear.
CPU IDLE ZERO	Alarm contact assigned FALt	Idle timer of CPU has counted to zero. This means that a CPU process has exceeded an allocated time slot. Possible during extended block transfer requests.

Process Alarms

The process alarms can be setup to activate either or both of the two alarm contacts provide on the VersaPro. Nine user selectable modes are available.

OFF

Disables the alarm function and the alarm contacts.

Full Scale HI

An alarm is generated any time the process value goes above the Full Scale HI alarm value. This alarm is reset if the process falls below the alarm value or acknowledgement from the front panel or through the event input (if configured).

Full Scale LO

An alarm is generated any time the process value drops below the Full Scale LO alarm value. The alarm will arm once the process is measured above the alarm value. This alarm is reset with an acknowledgement from the front panel or through the event input (if configured).

Deviation Band

An alarm is generated any time the process value goes above or below the band alarm setting. The alarm setting is \pm value of the band. For example, if a value of 10 is entered as the alarm value, an alarm is generated if the process goes 10 units above or 10 units below the set point. Units are the process units such percent or degrees. This alarm will not arm until the process is in-band of the set point.

Deviation High

An alarm is generated any time the process value goes above the band alarm setting. The alarm setting is number of units allowed above set point. Units are the process units such percent or degrees. This alarm will not arm until the process is in-band of the set point.

Deviation Low

An alarm is generated any time the process value goes below the band alarm setting. The alarm setting is number of units allowed below the set point. Units are the process units such percent carbon or degrees. This alarm will not arm until the process is in-band of the set point.

Output High

An alarm is generated any time the control percent output exceeds the alarm value. The alarm setting is maximum percent output allowed.

Output Low

An alarm is generated any time the control percent output drops below the alarm value. The alarm setting is minimum percent output allowed.

Fault

An alarm is generated any time an open input occurs on either the T/C or MV inputs. Both inputs are pull up to a maximum value if no input is connected or if the input fails in an open circuit mode. An open T/C input fault is ignored for the Linear configuration. The center display will indicate which of these conditions has caused the alarm. The alarm process will also become active if any of the listed hardware faults occur. The center display will indicate which of these conditions has caused the alarm.

Probe

An alarm is generated any time the probe exceeds the maximum probe impedance setting, or the verification test tolerance. All of the probe values and limits are configured in the Probe Menu. The center display will indicate which of these conditions has caused the alarm.

Time

This alarm setting is necessary for the timer function to work. The timer will only run if it is enabled in the Ctrl Setup menu and a timer setpoint value other

than zero has been assigned. This alarm setting allows the timer to start running when it is activated at the Start Timer parameter in the Setpt key menu, when the dual key combination Left Arrow and Enter keys are pressed, or if the Input Event has been configured for Start and a contact closure occurs. The timer will start running as soon as it starts, independent of any process values. See the Timer section for more details.

Start

This alarm setting is necessary for the timer function to work. The timer will only run if it is enabled in the Ctrl Setup menu and a timer setpoint value other than zero has been assigned. This alarm setting allows the timer to be activated from the Start Timer parameter in the Setpt key menu, when the dual key combination Left Arrow and Enter keys are pressed, or if the Input Event has been configured for Start and a contact closure occurs. The timer will start running as soon as the process level is above the alarm value and will continue to run once it has started. See the Timer section for more details.

Soak

This alarm setting is necessary for the timer function to work. The timer will only run if it is enabled in the Ctrl Setup menu and a timer setpoint value other than zero has been assigned. This alarm setting allows the timer to be activated from the Start Timer parameter in the Setpt key menu, when the dual key combination Left Arrow and Enter keys are pressed, or if the Input Event has been configured for Start and a contact closure occurs. The timer will start running as soon as the process level is within the band around set point determined by the alarm value. The timer will stop any time the process falls outside the band limit. See the Timer section for more details.

Alarm Action

Each alarm can be configured to operate in several different modes. Each alarm can be configured as a reverse (normally closed) contact. This mode is usually used for failsafe alarms that will open during an alarm condition, fault, or power failure. Each alarm can also be configured as a direct (normally open) contact that closes when an alarm condition occurs. In both cases the alarm will automatically clear if the alarm condition is resolved.

Each alarm can also be configured for either reverse or direct latched conditions. In this mode the alarm contact will remain active until an acknowledgement is received through the configured Event Input terminals or by pressing the ENTER key.

Alarm Delay Times

Each alarm can have delay ON, delay OFF, or both delays applied. Delays can be applied in increments of a second, up to a maximum of 250 seconds. ON delays are helpful if a known upset in the process can be ignored. This avoids nuisance alarms but still maintains an active alarm if the alarm condition persists following the delay. OFF delays will hold the alarm contact active for a determined period of time once the alarm condition has cleared. This can be helpful as an interlock to other process functions that may have to recover following an alarm condition.

Diagnostic Alarms

A diagnostic alarm is shown on the instrument's center display when a fault is detected in the internal hardware during power up. These alarms included:

FLASH CSUM FAULT	A	fault has been detected in the Flash memory.
EEPROM CSUM FAULT		A fault has been detected in the EEPROM.
KEYBOARD FAULT		A key is stuck or was held down during power up.
FLSH ERASE FAULT		This error may occur during instrument programming. The Flash memory may be faulty. Retry programming, make sure the communications link to the instrument is working properly.
FLSH SIZE FAULT		This error may occur during instrument programming. The Flash memory may be faulty. Retry programming, make sure the communications link to the instrument is working properly.
CPU IDLE ZERO		A CPU process has exceeded the allotted process time. Maybe due to extended serial communications block transfers. Limit the number of parameters requested in a block in this condition occurs.
CPU FAULT		Occurs if the CPU has not initialized correctly. Try resetting power.

If either alarm contact is configured for a fault this alarm will engage if any of the above faults occur. The LCD display will indicate the fault condition.

The front panel display will show LLLL if the process value is below the display resolution, or HHHH if the process value is above the display resolution. It may be necessary to adjust the carbon exponent and/or the carbon decimal point settings if these symbols occur.

Serial Interface

The VersaPro has a single RS-485 half duplex (two wire) communications port. This port can be configured for either the Marathon protocol or Modbus RTU protocol. Baud rates and parities are selectable. The Modbus protocol only uses a parity of none. See the section on communications for details on both of these protocols.

The Versapro can be connected to networks with up to 128 similar devices. The differential transceiver used in the Versapro meets or exceeds the TIA/EIA-485 and ISO/IEC 8482:1993(E) standards.

Connections for the serial interface should be connected to the following terminals:

TB-B 13	RTX +
TB-B 14	RTX -

All connections to any RS-485 bus should be made with shielded twisted pair wires using a low capacitance cable specified for RS-485 multi-drop connections. The shield should be connected to ground on one end of the wire run. Shield continuity should be maintained between wire segments. Each end of the network should be terminated with a resistor that is close to the impedance of the cable. 100 to 120 ohms are typical values. All connections to multiple instruments should be made in a daisy-chain fashion, from one instrument to the next. A star network connection should never be used. A repeater should be considered for cable distances beyond 3900 feet (1.2Km). Any network that is run between buildings should use repeaters with optical fiber connections between buildings to avoid any noise spikes generated by lightning strikes.

Front Panel Operation

The instrument has a display/keyboard assembly. This assembly has a 2 x 4 keyboard group, two groups of four LED seven segment displays (upper and lower), and a single line sixteen character LCD display.

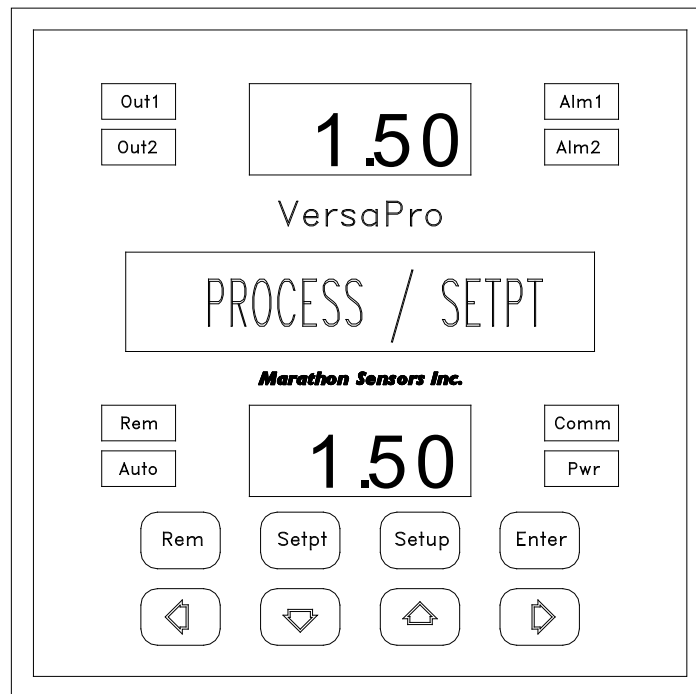

Figure 3 VersaPro Display

The LEDs to either side of the LED segment arrays light when the corresponding function is active.

- COMM flashes when the instrument is properly interrogated over the RS485 port.
- PWR is hard wired to the instrument 5VDC supply
- AUTO is lit when the instrument is controlling to a set point (controller option)
- REM is lit when the instrument is controlling to a remote set point (controller option)
- REM and AUTO flash together if the instrument is in manual mode (controller option).
- REM will flash if timer is running.

The upper display indicates the process value or the Setup Menu Heading when the SETUP key has been pressed.

The center display indicates what the measured process calculation is and what the lower display indicates. In figure 2 the instrument is indicating % carbon is being measured. This measurement range is 0 to 2.55%. The lower display shows the set point.

The center display also shows the parameter name in Setup mode or fault and alarm messages if any are active.

The lower display shows the instrument set point if the controller is in automatic or remote mode. The display will switch to control output level when the instrument is changed to manual. The lower display can also be configured to show the probe temperature

Enter Key

If the normal process display is showing on the LED and LCD displays, then pressing the Enter key will cycle the LCD and lower LED through various controller parameters. The display will cycle through

PROCESS / SETPT
PROCESS / TEMP
PROCESS / %OUT
PROBE MILLIVOLT
BOFF MILLIVOLT
PROBE IMPEDANCE
PROBE IMP RECOVERY
NEXT PROBE TEST
REMAINING TIME

The carbon or dew point process value will always be displayed in the top LED display depending on which process is selected in the control setup menu.

Each time an alarm occurs the particular alarm prompt will appear in the LCD display. The process information will continue to display normally if the Enter key is pressed. It is still possible to view any active alarm by pressing the UP or DOWN arrow keys.

Remote Key

Pressing the REM key causes the VersaPro to cycle between Remote, Automatic, or Manual control if it is a controller. This key has no function in the monitor version. When switching from Automatic to Manual or Manual to Automatic, the control output remains at the last output value in either mode. This allows for a bumpless control transition between either mode.

When the controller is set to Automatic mode the “Auto” LED lights and the lower display indicates the process setpoint (default).

When the controller is set to Remote mode the “Rem” LED lights and the VersaPro will accept a remote setpoint from a master on the host serial interface. The lower display indicates the process setpoint (default). The Setpt key does not work if the instrument is in remote mode. In some slave communications schemes the communications status may indicate an error unless the instrument is set to Remote mode.

When the controller is set to Manual mode both the “Rem” and “Auto” LED’s will flash together and the lower display indicates the power output of the controller. This value can be manually increased or decreased in 1% steps by pressing the UP or DOWN arrow keys. Pressing the RIGHT or LEFT arrow keys changes the output in 10% steps. The output will remain in the last control level if the instrument is switched into manual mode from remote or automatic or back to either setpoint control mode.

In setup mode, pressing the Remote key will back up the parameter list. Press the Enter key in this mode will proceed down the parameter list.

Setpt Key

The Setpt key provides access to the instrument local process and timer set points. When the key is pressed the center display will show “SET POINT” which is the process set point. The set point value in the lower display can then be manually changed by moving the flashing digit cursor with the RIGHT or LEFT arrow keys and increasing or decreasing the selected digit with the UP or DOWN arrow keys. If you press the Enter key the display will show the Timer Set Point. You can change this value in the same way. Press Enter again will ask if you want to start the timer. You can exit the set point function at any time by pressing the Setpt key. Any changes that are made to the set point are then displayed in the lower window if the instrument is set up of Automatic control.

The following table outlines the options available under the Set Point key.

Table 2 Setpoint Ranges

Parameter Name	Range	Description
SET POINT	0 – 2.55% carbon -99.9 – 212.0 dewpt -999 – 9999 linear	Units for carbon, dewpoint, or linear input.

TIMER SETPOINT	0 – 9999	Units in minutes
START TIMER	YES / NO	Starts timer when YES is selected. This is the same as pressing the dual keys LEFT arrow and Enter to start the timer.

If the instrument is left in the Set Point display mode the instrument will automatically return to the process display after one minute from the time the SetPt key was pressed.

Setup Key

The instrument can be placed in setup mode by pressing and holding the SETUP key for 5 seconds. The upper display initially shows the first setup menu while the center and lower displays are blank. At this level you can select different menus by pressing the RIGHT or LEFT arrow keys. The upper display will change accordingly.

You can enter a menu and proceed through the parameter list by pressing the ENTER key when the desired menu heading is being displayed. Pressing the Remote key will move up the parameter list. The parameter list will continually cycle by pressing either key. Pressing the arrow keys will change menu parameters. Value changes can be saved or the next parameter can be selected by pressing the ENTER key. A new menu can be select only when the menu heading is displayed, indicated by the blank lower display. You can exit from the Setup mode by pressing the SETUP key at any time.

The following tables outline the Setup menus available in the VersaPro Controller and Monitor when the operator presses the SETUP key.

Table 3 Setup Menus

Setup Menu Heading	Description
Ctrl	Control functions and PID
Inpt	Thermocouple type and Millivolt setup
CaLc	Process correction value and decimal point
Prob	Probe tests and verification parameters
Aout	Analog output selection and parameters
ALr	Alarm contact configurations
Host	Communication protocols and parameters
Info	General information displays
CaL	Input / Output calibration

You have to press the SETUP key for five seconds to activate the setup mode. Initially when the setup mode is activated, the upper LED display will show the first menu heading, the LCD and lower LED displays are blank. Page to the next Menu heading by pressing the RIGHT or LEFT arrow keys. The menu headings will continue to wrap around as the RIGHT or LEFT arrow keys are pressed. Pressing

the SETUP key at any point while in the Setup Menus will return the display to the normal process display. See figure 3.

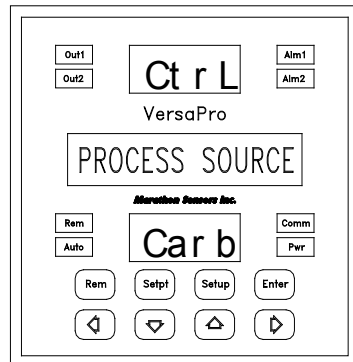

The displayed menu is selected by pressing the ENTER key. The first parameter name in the selected menu list will appear in the center display. The upper LED group continues to display the menu name, and the lower LED group shows the parameter value. A flashing cursor in the lower LED display indicates which digit can change if the parameter value is numeric. The UP or DOWN arrows increase or decrease the digit

value. The RIGHT or LEFT arrow keys move the cursor to the right or left digit. Numeric wrap-around is provided as well as wrap-around for the menu parameters. No wrap-around is provided for the cursor position when changing a parameter value.

If the parameter has a table of choices such as thermocouple types, the various selections can be displayed by pressing the UP or DOWN arrows. No digit flashes in parameters that have a list selection. In either case, the selection is set when the ENTER key is pressed and the display advances to the next parameter.

In the example shown above, the selected menu is Control (Ctrl), the selected parameter is Process Source, and the selected source is carbon. Different source selections can be made by pressing the UP or DOWN arrow keys.

Pressing the REM key will back the display up toward the beginning of the menu. Pressing the Enter key will advance down through the menu. The menu display will wrap around to the top of the menu when the ENTER key is pressed at the last parameter..

Pressing the SETUP key at any time escapes from the menu display and returns to the normal process display. You can only select another menu heading when the display is at a menu heading.

The following figures and tables outline the menu options and parameters under the Setup key.

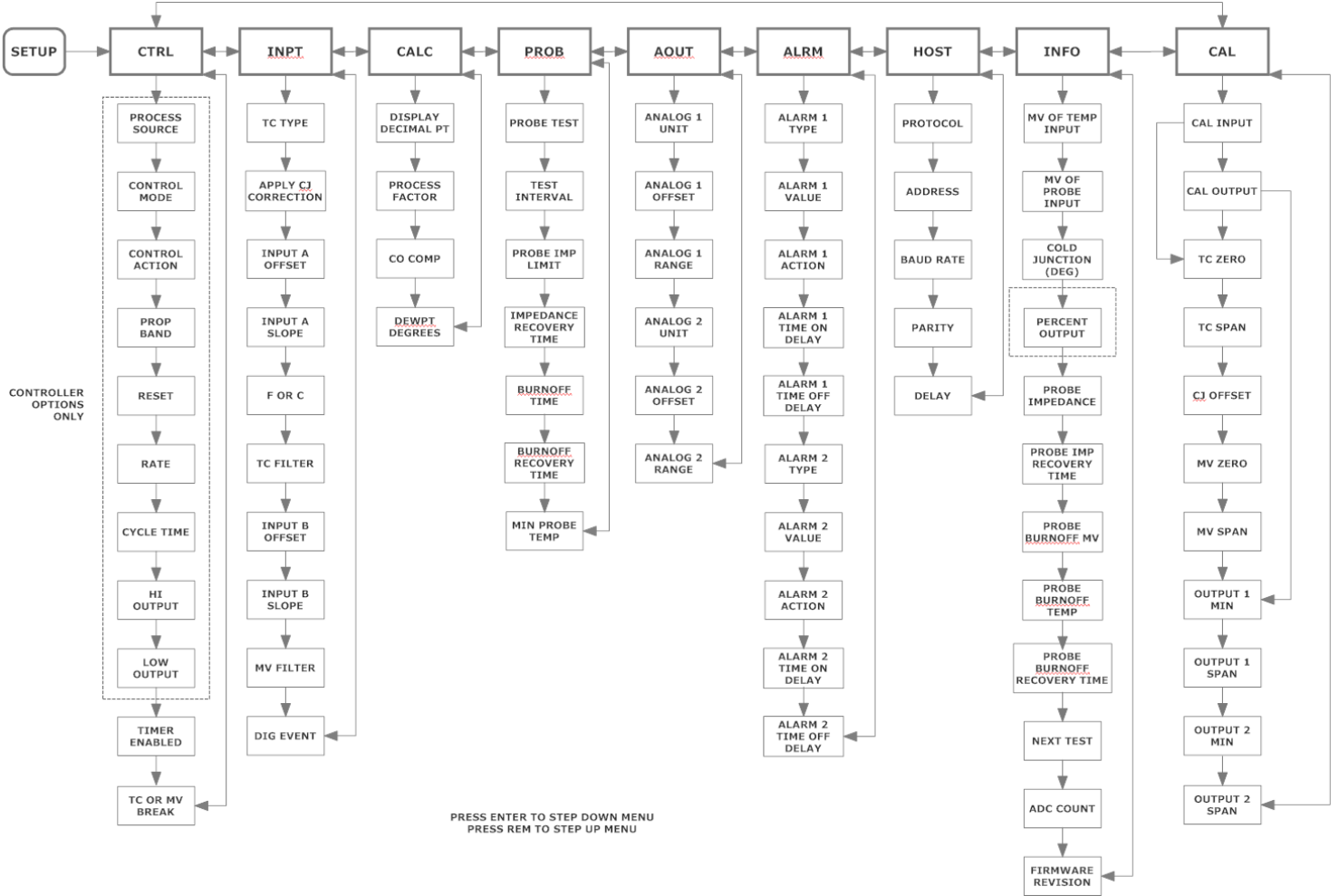

Figure 4 Setup Menu Tree

Table 4 Control Menu (Ctrl)

Parameter Name	Units or Options	Range	Description
PROCESS SOURCE	CARB, DPT, LInA, LInB	Carbon range: 00.00 to 02.55 Dewpt range: -99.9 to 212.0 -999 to 9999 for Input A or Input B	Control type only available on instrument's specific configuration. This selection controls what other parameters will be available. E A is input A (0-50mV), E B is input B (0-2000mV)
TC OR MV BREAK		ZERO, HOLD	ZERO sets the control output to 0 if a thermocouple break and/or an open mV input are detected. HOLD holds the output and the last process value prior to an opened input. HOLD will take effect temporarily if the mV signal changes by more than 50mV

Parameter Name	Units or Options	Range	Description
			between samples. This prevents changes if the mV signal is failing.
The following parameters in this table are only available in the controller			
CONTROL MODE	TP, TC, TD, PP, OF, OC, OD or NON		See Control Modes if configured as a controller, shows NON (MONITOR) only if the instrument is configured as a monitor. Check the HI and LOW percent output settings when this parameter is changed.
CONTROL ACTION	DIR/REV		Direct or Reverse control action
PROPORTIONAL BAND	Process Value	0 – 9999	Proportional Band value in displayed process units for PID control or Deadband in ON/OFF control
RESET	repeats/min	00.00 – 99.99	Integral control value, no effect in ON/OFF settings
RATE	Minutes	00.00 – 9.99	Derivative control value, no effect in ON/OFF settings
CYCLE TIME	SECONDS	0 – 250	Proportional time period (TP, TC, TD) Motor cycle time (PP) Minimum ON time (OF,OC,OD)
HI PERCENT OUT (HIPO)	MAXIMUM OUTPUT	0 – 100	Sets max. forward control. Output
LOW PERCENT OUT (LOPO)	MINIMUM OUTPUT	-100 to 100	Sets min. reverse control output
TIMER ENABLE	YES / NO		Enables timer function

Table 5 Input Menu (InPt)

Parameter Name	Units or Options	Range	Description
TC TYPE	B, E, J, K, N, R, S, T		See Input calibration for thermocouple ranges. Linear mode allows for input scaling, see IN A OFFSET and IN A SLOPE.
COLD JUNC APPLY	YES or NO		Applies the cold junction correction or not when a thermocouple type is selected. In LINEAR mode the cold junction is never applied. Default is NO.
IN A OFFSET	Only in Linear	-999 – 9999	Linear offset to scale Input

Parameter Name	Units or Options	Range	Description
	mode		A to Engineering Units when INPUT A is selected as the process source.
IN A SLOPE	Only in Linear mode	-999 – 999 -99.9 – 99.9 -9.99 – 9.99 -.999 - .999	Linear slope to scale Input A to Engineering Units when INPUT A is selected as the process source. This is the slope number in the linear calculation where: $EU = SLOPE(mV) + OFFSET$ See key
TEMP SCALE	F OR C		Sets temperature scale.
TC FILTER		1 – 450	Temperature filter setting in seconds. Filters the temperature value with a moving average time window.
IN B OFFSET	Works only in mV Mode	-999 – 9999	Linear offset to scale Input B to Engineering Units when INPUT B is selected at the process source. This is the offset in used in the $SLOPE(mV) + OFFSET$ equation.
IN B SLOPE	Works only in mV Mode	-999 – 999 -99.9 – 99.9 -9.99 – 9.99 -.999 - .999	Linear slope to scale Input B to Engineering Units when INPUT B is selected as the process source. This is the slope number in the linear calculation where: $EU = SLOPE(mV) + OFFSET$
MV FILTER		1 – 450	Millivolt filter setting in seconds. Filters the millivolt reading with a moving average time window.
DIG EVENT	OFF, PrOb, AUtO, rEn, ACK, PrOC, Strt, HOLd, End		See Digital Event section for an explanation of selections. See the Timer section for the Strt, HOLd, and End selections.

Table 6 Calculation Menu (CALC)

Parameter Name	Units or Options	Range	Description
DISPLAY DECML PT	Decimal point	0-4	Sets decimal pt., for Input A and Input B. Carbon defaults to 2.
PROCESS FACTOR		0 – 1999	Used to correct displayed carbon value when compared to shim stock readings. The default is 150.
COMPENSATION	Carbon Monoxide %	10-50	CO% of process atmosphere. The default is 20% with a Process Factor of 150. If CO Compensation value is to be adjusted then keep Process Factor at 150.
DEWPT DEGREES	F, C		Select °F or °C for dewpoint calculation.

Table 7 Probe Setup Menu (PrOb)

Parameter Name	Units or Options	Range	Description
PROBE TEST		NONE RES BOFF BOTH	No test (NONE), Impedance (RES), Burnoff (BOFF), or BOTH impedance and burnoff can be selected.
TEST INTERVAL	HRS.TENTHS	0 – 99.9	Sets time interval between automatic probe tests, 0 disables automatic testing.
PROBE IMP LIMIT	KOHMS	10 – 100	Sets maximum impedance for Probe alarm
IMP RECVRY TIME	SECONDS	0 – 250	Sets maximum Probe recovery time, timer cut short if probe recovers faster. The Probe alarm is set if the probe signal does not recover while this timer is active.
BURNOFF TIME	SECONDS	0 – 999	The period of time when air is allowed to flow to the tip of the sensor.
BURNOFF RECOVERY	SECONDS	0 – 999	Recovery time for probe following the burnoff test. The PROBE alarm is set if the probe signal does not recover before this timer expires.
MIN PROBE TEMP	F OR C	1100° – 2000° F 590° – 1090° C	Minimum temperature for probe impedance and

Parameter Name	Units or Options	Range	Description
			verification tests.

Table 8 Analog Output Menu (AOUT)

Parameter Name	Units or Options	Range	Description
ANALOG 1 UNIT	Proc, LInA, TENP, POUT, PO1, PO2, PROG, LInB	4 to 20mA output.	<p>Proc – retransmits Carbon or Dewpoint depending on the control process selection.</p> <p>LInA – scaled millivolt value of input A depends on which input selected as process source.</p> <p>TENP – probe temperature when carbon is selected as process source and a thermocouple type is selected.</p> <p>POUT – Power output is available for the controller, allows for –100% to 100% for split actuators. PO1 or PO2 allow for just 0 – 100% output for either control contact.</p> <p>PROG - allows the output to be controlled from the DACV1 memory location.</p> <p>LInB – scaled millivolt value of input A depends on which input selected as process source.</p>
ANALOG 1 OFFSET	Offset for selected process value or percent output.	<p>-99.9 to 300.0 for Proc, LInA or LInB</p> <p>-300 to 3000 for temperature</p> <p>LOPO for POUT</p> <p>0 or DAC_OFFSET for PROG</p>	<p>This is the minimum value of the process associated with the 4mA output. The magnitude of this number is based on the display resolution.</p> <p>In POUT mode the offset is fixed to the LOPO value. When PROG is selected the offset is fixed at 0</p>
ANALOG 1 RANGE	Span scaling for selected process value or percent output.	<p>0 to 9999 for Proc, LInA, LInB, and Temp</p> <p>HIPO for POUT</p>	<p>This is the maximum value of the process associated with the 20mA output. The magnitude of this number is based on the display resolution. When POUT is</p>

Parameter Name	Units or Options	Range	Description
		4096 or DAC_SPAN for PROG	selected this value is fixed to the HIPO value. When PROG is selected the range is fixed at 4096
ANALOG 2 UNIT	Proc, LInA, TENP, POUT, PO1, PO2, PROG, LInB		Same as Analog 1
ANALOG 2 OFFSET	Offset for selected process value or percent output.		Same as Analog 1
ANALOG 2 RANGE	Span scaling for selected process value or percent output.		Same as Analog 1

Table 9 Alarm Menu (ALr)

Parameter Name	Units or Options	Range	Description
ALARM 1 TYPE	OFF FSHI, FSLO dUbd dbHI dbLO HIPO LOPO FALt PROB tinE Strt SOAk		OFF disables alarm contact. FSHI - Full Scale HI , active when process is above ALARM 1 VALUE. FSLO - Full Scale LO , active when process is below ALARM 1 VALUE. dUbd – Deviation Band available for the controller only, active when process is outside of symmetrical band around setpoint. dbHI – Deviation High , defines a process band above the process setpoint. The alarm is active if the process moves outside this band. dbLO – Deviation Low , defines a process band below the process setpoint. The alarm is active if the process moves outside this band. HIPO – Output High , this alarm sets the threshold for the maximum control output allowed which is set by ALARM 1 VALUE. LOPO – Output Low , this

Parameter Name	Units or Options	Range	Description
			alarm sets the threshold for the minimum control output allowed which is set by ALARM 1 VALUE. FALt – Fault , open inputs for mV, thermocouple or hardware fault. Prob – Probe , fault active if impedance or verification are out of range. tinE – Time , establishes alarm contact as the contact used for the End alarm. Strt – Start , same as Time. SOAk – Soak , same as Time.
ALARM 1 VALUE			Trigger set point value
ALARM 1 ACTION	REV, LREV, DIR, LDIR		REV = Reverse (N.C.) can be acknowledged even if the condition still exists. LREV = Latched Reverse (N.C.) cannot be acknowledged if the condition still exists. DIR = Direct (N.O.) can be acknowledged even if the condition still exists. LDIR = Latched Direct (N.C.) cannot be acknowledged if the condition still exists.
ALRM 1 TM ON DLY	0 – 250 SECONDS		Delay ON time for ALARM1
ALRM 1 TMOFF DLY	0 – 250 SECONDS		Delay OFF time for ALARM1
ALARM 2 TYPE	Same as ALARM 1 TYPE	OFF	Same as ALARM 1 TYPE
ALARM 2 VALUE			Trigger set point value
ALARM 2 ACTION			Same as ALARM 1 ACTION
ALRM 2 TM ON DLY	0 – 250 SECONDS		Delay ON time for ALARM2
ALRM 2 TMOFF DLY	0 – 250 SECONDS		Delay OFF time for ALARM2

Table 10 Communication Menu (HOST)

Parameter Name	Units or Options	Range	Description
PROTOCOL	PROP OR BUSS		PROP is United Process Controls, Inc. slave

Parameter Name	Units or Options	Range	Description
			protocol, BUSS is RTU Modbus protocol.
ADDRESS	1 TO 15 (MMI)		
BAUD RATE	1200,2400,4800,9600,19.2K		
PARITY	None/Even/Odd		Modbus uses None parity only.
DELAY	NONE, 10, 20, 30		NONE = 0 Delay, other selections are millisecond delay in response.

Table 11 Info Menu (InFO)

Parameter Name	Units or Options	Range	Description
MILLIVOLT TEMP IN	MILLIVOLTS	-10-100	Displays direct mV of Temperature input. NOTE: This value is affected by the cold junction correction. Turn off the cold junction compensation to read the input millivolts directly.
MILLIVOLT PROB IN	MILLIVOLTS	0-2000	Displays direct mV reading of probe input
COLD JUNCTION	DEG (F OR C)	0 – 60°C	Displays actual cold junction temperature
PERCENT OUTPUT	% Output	LOPO to HIPO	Displays actual % output
PROB IMPEDANCE	Kohms	0 – 100	Displays last probe impedance value.
IMP RECVRY TIME	SECONDS	0 – 250	Displays last impedance recovery time.
BURNOFF MV	MILLVOLTS	0 – 2000	Millivolts read at the end of the probe burnoff cycle
BURNOFF TEMP	°F OR °C	0 – 2000	Displays probe temperature read at the end of the probe burnoff cycle
BURNOFF RECVRY TIME	SECONDS	0 – 250	Time taken for probe to return to 98% of pre-test millivolt reading.
NEXT TEST	Hours.tenths		Time to next probe test, shows 00.0 if test automatic test is disabled.
ADC COUNT	Counts	0-255	Tracks any faults in ADC
FIRMWARE REV	Version number		

Table 12 Calibration Menu

Parameter Name	Units or Options	Range	Description
CAL INPUT	NO / YES		Default to NO, must be changed to YES to enter input calibration routine.
TC ZERO (CAL IN)			Changes calibration value for input A zero. The displayed value will be different depending on the process source. Temperature for Proc, or millivolts for E A (input A).
TC SPAN (CAL IN)			Changes calibration value for input A span. The displayed value will be different depending on the process source. Temperature for Proc, or millivolts for E A (input A).
PROBE mV ZERO (CAL IN)			Changes calibration value for millivolt zero (input B)
PROBE mV SPAN (CAL IN)			Changes calibration value for millivolt span (input B)
CJ OFFSET (CAL IN)		0 – 60° C 0 – 140° F	Sets the cold junction offset depending on the temperature range selected
CAL OUTPUT	NO / YES		Default to NO, must be changed to YES to enter output calibration routine.
OUTPUT 1 MIN (CAL OUTPUT)			Sets signal level for the minimum mA output.
OUTPUT 1 SPAN (CAL OUTPUT)			Sets signal level for the maximum mA output.
OUTPUT 2 MIN (CAL OUTPUT)			Sets signal level for the minimum mA output.
OUTPUT 2 SPAN (CAL OUTPUT)			Sets signal level for the maximum mA output.

Pressing the Setup key once at any point in the Setup menu will return the instrument to the normal process display.

Dual Key Functions

The VersaPro has four dual key functions as defined below:

RIGHT arrow / Enter

Start probe test sequence if stopped or stops probe test if running

LEFT arrow / Enter

Start Timer

DOWN arrow / Enter

Edit Remaining Timer

Rem / Enter

Monitor Mode

Starting / Stopping Probe Tests

Pressing the RIGHT arrow / Enter keys simultaneously will start the probe tests if a probe test function has been selected in the Probe Setup Menu, parameter Probe Test, and the probe temperature is above the minimum probe temperature parameter in the same menu. If a probe test is running, these same keys will stop the test. It should be noted that stopping a probe test manually may cause an up set in the furnace depending on what test was running at the time the test was stopped.

If there is a value other than 0.0 entered in the Probe Test Interval parameter the probe test will be performed after the selected interval time has elapsed from the time the test was manually started. If the interval time is set to 0.0, then no additional tests will be performed until the next manual start. Starting the test through this dual key function is the same as if the Start Test parameter in the Probe menu had been changed from NO to YES or if the PMC (probe maintenance control) word was set to 0 via serial communications.

Start Timer

Pressing the LEFT arrow / Enter keys simultaneously will start the timer if the timer has been enabled in the Control Setup menu, the timer set point is greater than zero, and an alarm contact has been assigned a timer function. Press both keys while the timer is running will stop the timer.

Edit Timer

Pressing the DOWN arrow / Enter keys simultaneously while the timer is running will allow the remaining time to be changed. The remaining time can be increased or decreased. The change in time takes effect when the Enter key is pressed and the display returns to the normal remaining time display.

Monitor Mode

Monitor Mode is used by factory personnel only. Return to operate mode by cycling power or sending the appropriate command word to the instrument.

Digital Input Event

The VersaPro has a single digital input. This input is activated by making an isolated contact closure between terminals TB-B 11 and 12. This input is debounced for a momentary closure of at least 0.6 seconds.

NOTE

Do not connect either terminals TB-B 11 or 12 to any AC or DC potentials. These terminals are internally

connected to an isolated 5VDC source. Use only an isolated contact closure across these terminals.

The input event can be set to any one of the following functions: OFF, PrOb (start probe test), AUTO (set to auto), rEn (set to remote), ACK (alarm acknowledge), PrOC (process hold), Strt (timer start), HOLd (timer hold), End (timer end acknowledge). These settings can be selected in the Input Setup menu at the DIG EVENT parameter. The selections can be made by pressing the up or down arrow keys and then pressing the Enter key.

OFF

This selection disables the input event function. This is the default condition of this feature unless another function is selected.

PROB

This selection will start the impedance (10Kohm) test and/or probe burnoff. The various probe tests will run only if they are selected in the Probe Menu. The PrOB input event will have no effect if no probe tests are selected.

If a probe test interval time is set to any value other than zero, activating this function will reset the interval countdown timer. If the probe test interval time is set to zero this function will operate only when the contact closure is made across the event input terminals. The contact closure must open and close each time to initiate another probe test.

AUTO (controller only)

This selection will force the instrument from manual mode or remote mode into local automatic mode. No change will occur if the instrument is already in automatic mode.

rEn (controller only)

This selection will force the instrument from local setpoint mode or manual mode into remote setpoint mode. No change will occur if the instrument is already in remote setpoint mode.

ACK

This selection will acknowledge any latched active alarm except the timer end alarm. This function will have no effect if the alarm condition persists when the acknowledge signal is issued. This function resets a latched alarm similar to pressing the Enter key.

PrOC (controller only)

This selection will place the process calculation in hold. The control output is also held at the output level when the process hold event was set. This includes all analog output signals as well as control contacts. This is similar to the state the instrument is set to when the probe tests are running.

Strt (controller only)

This selection will start the timer function if the timer is enabled, the set point is greater than 0, and one alarm contact is assigned to a timer function.

HOLd (controller only)

This selection will place the timer in a hold state for as long as the event input is active.

End (controller only)

This selection will acknowledge the end condition of the timer, clear the end state, and reset the timer for another start.

Timer Function

The Versapro timer function is available on all process controller options. The timer can operate independently or it can be dependent on the process based on how either alarm contact is configured. The instrument has three possible functions; timer, guaranteed start timer, and guaranteed soak timer. These functions are set through the mode selection of alarm 1 or alarm 2 in the Setup menu. Only one alarm should be set to a timer function at any time.

The timer will only work if three conditions are met; the timer function must be enabled in the Setup Control Menu, an alarm contact must be configured for a timer function, and the timer set point must be greater than zero.

The timer set point is set in the Setpt Key menu. The remaining time is displayed in the display cycle list and can be edited when the timer is running. The timer set point is entered in whole minutes. The remaining time will show the tenths of a minute if the timer is less than 1000 and shown as whole minutes. The timer start setting follows the remaining time display in the Setpt Menu.

Setting the Timer

The first step for using the timer is to enable the timer function in Setup Control Menu. This allows the timer to be started in various ways and also allocates a serial port channel for the timer.

The next step is to move to the Alarm menu and select a timer function for one of the alarms. The alarm that is selected will close its alarm contact with the timer counts to zero. Only one alarm should be selected for a timer function and any time.

NOTE

Do not set both alarms to timer functions at the same time.

The final step is to press the Setpt key and the Enter key until the TIMER SETPT parameter appears. Enter the desired value of the timer. This value is the only set point for the timer. This value will be used as the timer set point if the instrument is in the local automatic or remote control mode. There is no separate remote timer set point value. The local timer set point value will be over written by the value received from a remote device like a computer or master instrument.

The final step is to start the timer. This can be done in the Setpt menu by pressing the Enter key until the TIMER START parameter appears and selecting 'YES'. The

timer can also be started by pressing a dual key sequence LEFT arrow and Enter, through the serial interface, or through the digital event input.

Timer Dual Key Functions

← + Enter

In Auto or Remote mode this two key combination will activate or deactivate the timer function.

⇩ + Enter

This two key combination allows the timer function remaining time to be edited.

The behavior of the timer is controlled through the selection of the alarm modes. If no timer alarm is selected for either alarm 1 or alarm 2 then the timer will not start. The Time, Start, or Soak alarm modes must be selected for one alarm contact before the timer will start.

The Rem LED on the front panel will flash while the timer is active in the RUN, HOLD, or END modes. The timer will go inactive when END is acknowledged or if the timer is disabled.

The timer can be stopped by pressing the Enter and Right arrow keys during an active RUN state, sending a remote timer set point of 0 when the instrument is in remote mode, or by changing the remaining time to zero.

The Event Input can be configured to start the timer, hold the timer, or acknowledge the End state.

Time

The Time alarm mode it will run continuously once it has started and the alarm contract will close when the remaining time reaches zero. The alarm value has no effect in the simple timer mode and the timer will not stop or hold if the process value changes. The alarm message is 'End' will display on the LCD screen and the appropriate alarm contact will activate.

Guaranteed Start Timer

The guaranteed start timer function works in conjunction with the alarm value. The timer will hold until the process value is greater than the lower band value of the process. The alarm value is the band value. In the figure below the alarm value is 10, which represents a band around set point of $\nabla 10^{\circ}$. The timer will not HOLD once it has met the initial starting conditions. The process can fluctuate outside of the alarm band after the timer has started without placing the timer in a HOLD state. The following figure shows the behavior of the guaranteed start timer.

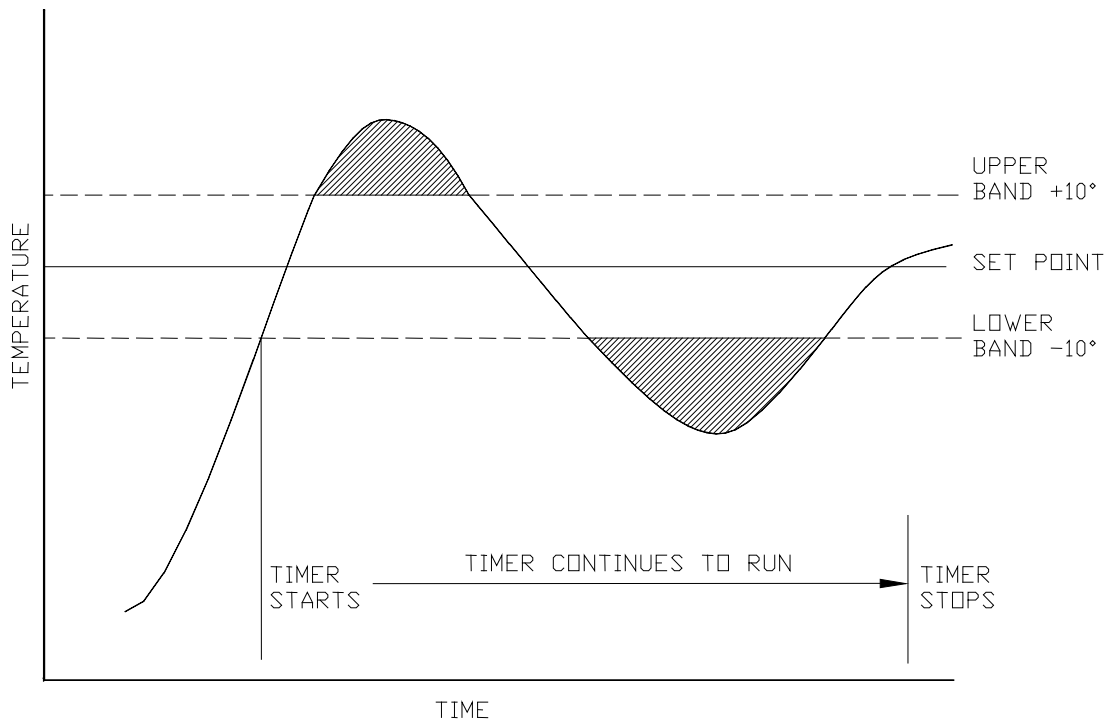

Figure 5 Guaranteed Start

Guaranteed Soak Timer

The guaranteed soak timer works in conjunction with the alarm process value. The alarm value is the valid band around the process set point. The process must be within the band around the process set point to start the timer once it has been activated. If the process passes above or below the alarm band setting, the timer will go to a HOLD state. The timer will be allowed to continue only when the process is within the band setting. In the following figure the alarm value is set to 10 degrees for a temperature process.

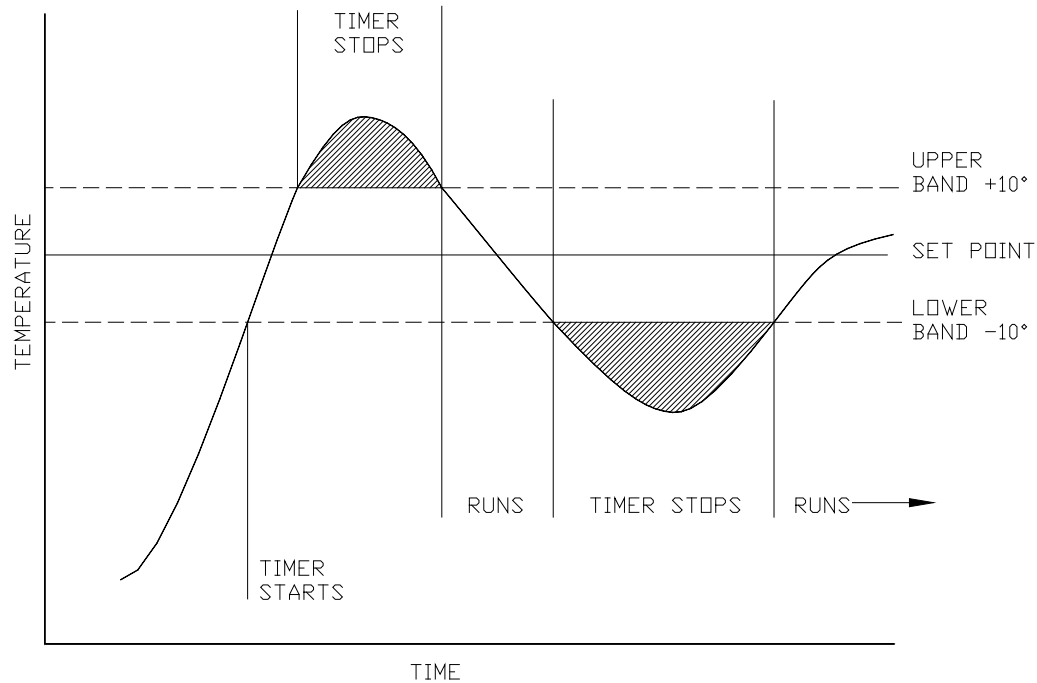

Figure 6 Guaranteed Soak

Timer Alarm Behavior

The alarm contacts do not work like normal process alarms when the timer, soak, or start timer functions are selected. If the alarm is configured for the timer, the contact will only activate when the remaining time counts down to zero and the timer reaches the END state. Once this occurs the END Alarm message will appear on the LCD display. The alarm will stay latched until it is acknowledged by pressing the Enter key or closing a contact across the Digital Event terminals if the End setting is selected as the Digital Event function. The Rem light flashes during the END state and stops flashing when the timer is acknowledged and returns to the IDLE state.

Timer State Diagram

The following diagram shows the conditions that control the state of the timer function.

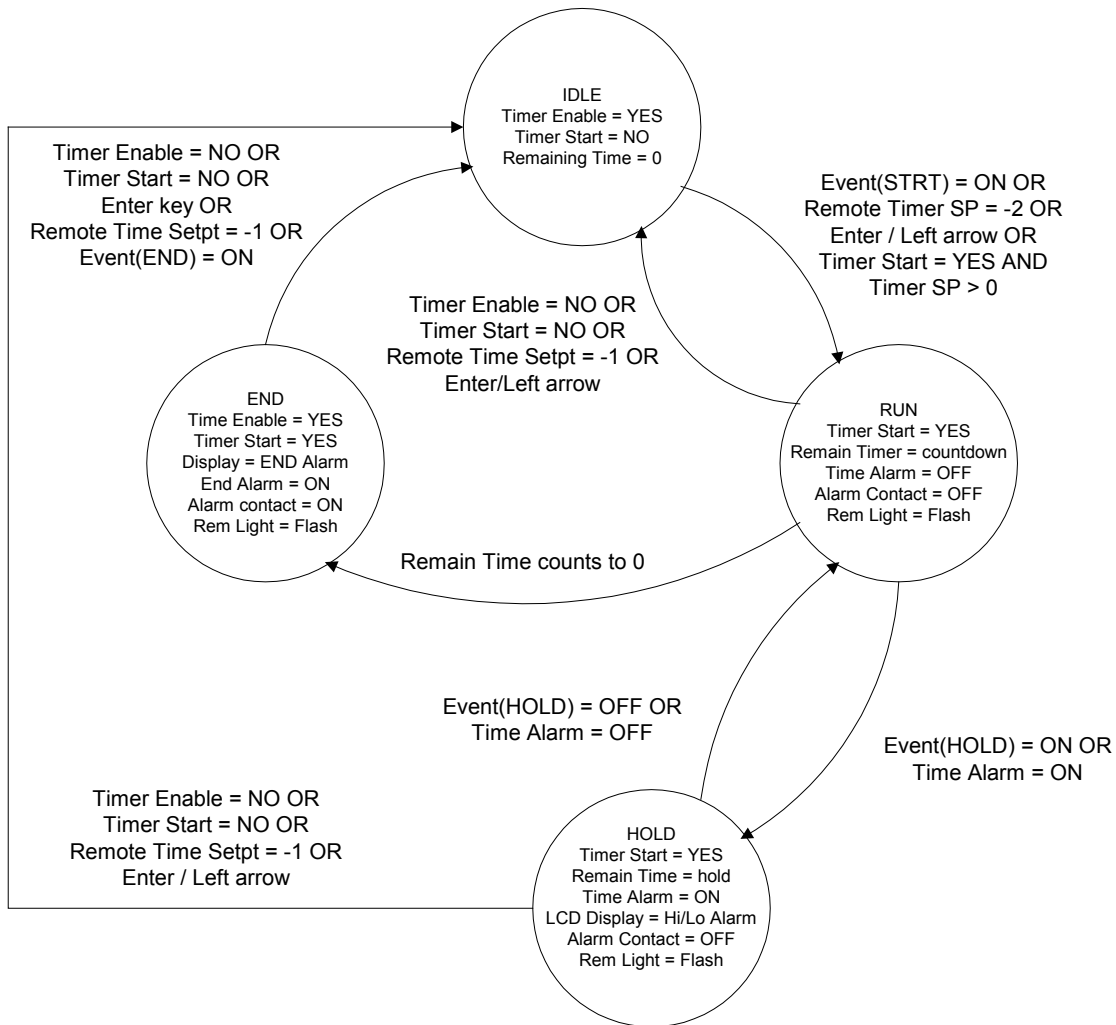

Figure 7 Versapro Timer State Diagram

The timer has four states. The IDLE state is the inactive condition. The RUN state is the active state when the timer is counting down. The HOLD state is when counting is paused due to either Digital Event = HOLD or a configured alarm is active. The END state is when the timer has timed-out but has not been acknowledged. The configured alarm contact will activate when the END state is entered.

The following is a summary of ways to change the state of the Timer. These assume the standard setups are in effect. It is assumed that the Timer is enabled for it to start or run.

Timer will start if:

1. Timer Enable = YES and
2. Alarm is set to timer function and
3. Timer Setpoint > 0 and
4. Digital STRT event = ON or
5. Enter/Left keys = CLOSE or
6. Timer Start = YES or

7. Remote Setpoint = -002

Timer will hold if:

1. Digital HOLD event = ON or
2. Alarm Soak or Run deviation is active

Timer will run if:

1. Timer Enable = YES and
2. Timer Start = YES and
3. Timer Setpoint > 0 and
4. Digital HOLD event = OFF and
5. Remaining Time > 0

Timer will reset to IDLE without activating END if:

1. Enable = NO or
2. Timer Start = NO or
3. Remote Timer setpoint = -001 or
4. Enter/Left keys pressed

Timer goes to END state if:

1. Timer countdown reaches 0

Timer returns to IDLE state from END when:

1. Enable = NO or
2. Timer Start = NO or
3. Operator presses Enter key or
4. Remote Timer setpoint = -001 or
5. Digital END input = ON

Timer SIO Operations

The Versapro allocates a second host address if the timer function is enabled and the host port protocol is set to PRoP (Marathon) using the Marathon slave protocol. If the host port protocol is set to buss (Modbus) or the Marathon block protocol is used, then the timer information is accessed directly. For the Marathon slave protocol, the first address is the primary address set by the Address parameter setting in the Setup HOST menu. The second address is assigned as Address +1 and will respond to 10Pro type commands. The setpoint commands affect the timer set point. The initial state conditions must be met for the timer to run.

The remaining timer value will be transmitted as the process value when responding in 10Pro slave mode. The timer values and process values are available at the host address if the instrument is responding to the Marathon block command or Modbus. The Address + 1 address is always active while the timer is enabled and the serial port protocol selection is MMI and inactive when Modbus is selected. It is important to consider this extra address allocation if multiple slaves with timers are going to be connected to a master. Only eight addresses are possible when the 10Pro command mode is used. See the section on serial communication for details on these differences. If only the Marathon block command is going to be used then the instrument will not respond on the second address.

In the MMI 10Pro protocol, the value returned for the percent output command is the timer control byte. The bits in the control byte are defined in the following table.

Timer Control Byte

Bit	Description	Purpose
0	Timer Enabled	Indicates that the timer is enabled in the setup menu.
1	Timer Running	Indicates that the timer has started.
2	End	Indicates that the timer has timed out and not acknowledged.
3	Hold	Indicates that the timer is in hold mode.
4 & 6	N/A	Not used.
7	Control	Set when the timer is started. Reset when timer has stopped. Is toggled by the Enter + Left Arrow or set by the SIO sending a time setpoint.

Controlling the Timer Remotely

All timer setpoint values must be written to the host address + 1 and the timer function must be enabled in the instrument control menu for the instrument to recognize any host address + 1 command.

Control of the timer via the serial port using the 10Pro commands has limited capabilities since the only value that can be written is the time set point. There are special cases if the Versapro is connected to Dualpro/Multipro as a slave. The master instrument must first send a valid setpoint value from 1 to 9999. The master can then send a setpoint of -002 to start the timer assuming all other configuration requirements are met. If the master sends a setpoint of -001 the timer is reset and stopped with no End alarm.

The master can set the timer functions, alarm values, and delay times using the Marathon Block or Modbus protocols. The sequence of events is similar for either Marathon Block or Modbus protocol.

The timer control word is located at parameter 70, Timer Control and Event (TCE). The timer control byte is the upper byte of this word. The input event configuration is in the lower byte of this word. Any configuration of the input event must be added to the timer function values when this word is written to the Versapro. In this example the event configuration is set to none (0). It is suggested that this word be read by masking the upper byte of the word to record the input event configuration. This value can then be added to the following timer control values to retain the input event configuration.

The timer will only work when it is enabled, the timer setpoint is greater than 0, and at least one alarm mode is set to a timer function. The alarm mode has to be manually configured. Programming the timer involves the following sequence:

- Enable the timer by writing a value 32768 (0x8000) to TCE.
- Set the timer setpoint by writing setpoint value to parameter 3 (TSETPT)
- Start the timer by writing a value 33024 (0x8100) to TCE.

- The timer will indicate it has timed out when TCE = 34560 (0x8300).
- Acknowledge the end alarm by writing a value 0 (0x0000) to TCE.

A description the TCE word and the timer flags in the TCE word can be found in the Versapro Memory Map table.

Sensor Impedance Test

The sensor impedance test is performed by measuring the open circuit voltage of the sensor, applying a known shunt resistor across it and measuring the shunted voltage output. The value of the shunt resistor is 10kohm for carbon sensors.

To run a sensor impedance test it is necessary setup the sensor testing parameter in the SETUP Sensor Menu. Please refer to Probe parameters table for an explanation of these setup parameters. It is necessary to have the impedance (RES) test or both (BOTH) selected at the PROBE TEST parameter in order to run the impedance test. You may choose to accept the defaults for the other parameters in this menu or change them to suit your applications.

NOTE

It is necessary that the sensor be above the MIN PROBE TEMP parameter setting for this test to run. It is also necessary that the sensor is measuring a stable process gas during this test.

There are two ways to start this test. The first way to start the test is by pressing the ENTER and RIGHT ARROW keys at the same time. The test can be stopped by pressing the ENTER and RIGHT ARROW keys again. The sensor test must be specified in the probe setup menu and the sensor temperature must be above the minimum temperature for any test to run.

The second way to start the sensor test is to write a 1 to the PSTART (Probe Start) word in the instrument memory Block 3 Parameter 72 via the serial communications interface. Refer to the instrument memory map for details on the format of this word. The instrument will reset this value when the test starts and will ignore any changes while the test is running.

The following table explains the various operations of the impedance test.

If the TEST INTEVAL parameter has a number other than 00.0 then the test will continue to run each time the test interval timer counts down to 0. This test interval can be stopped by setting the interval timer to 00.0.

Table 13 Sensor Impedance Sequence

Sequence #	Description
1	Inhibit process variable calculations. Freeze all process controls and outputs.
	Freeze alarms at last state except clear any previous probe test failure alarm.
	Store present probe millivolt reading
	Apply shunt resistor across probe
2	Wait for impedance test timer, fixed time of 30 seconds
	Compute impedance of probe and remove shunt resistor. Save measured impedance as PROBE IMPEDANCE in INFO menu.
	If impedance is greater than PROBE IMP LIMIT then set probe test failure alarm.
3	Wait for probe to recover to $\geq 99\%$ of original millivolts.
	Evaluate actual recovery time to IMP RECVRY TIME
	If recovery time is greater than IMP RECVRY TIME then set probe test failure alarm.
	Store recovery time (or max value) as IMP RECVRY TIME in INFO menu
4	If verification is to be performed then go to step 1 of verification sequence
	Otherwise wait 30 seconds and resume normal operation of all instrument functions.

Why Measure Sensor Impedance?

It is important to track sensor impedance over a period of time to help determine the replacement schedule for the sensor. A high impedance ($>50 \text{ K}\Omega$) indicates that the electrode contact on the sensor zirconia has deteriorate to a level that probably warrants replacement. High sensor impedance results in a lower signal output from the sensor and an eventual failure of the electrode connection on the process side of the zirconia ceramic. This deterioration is more of a factor in highly reducing atmospheres. In such applications, it may be necessary to check the impedance at least once a month. Under light reducing, annealing, or brazing operations, the impedance may not have to be check unless there is a question about the sensor's performance.

A typical impedance for a new sensor is less than $1 \text{ K}\Omega$. As the sensor starts to age the impedance will increase. Past 20 KOHM the sensor should be monitored more closely. Above $50 \text{ K}\Omega$, the sensor should be replaced. If it is necessary to replace the sensor, remove it carefully, following the instructions supplied with the sensor. Do not discard a sensor with a high impedance. It may be possible to rebuild the sensor if the ceramic parts are intact. Contact United Process Controls, Inc. for information on rebuilding your sensor.

An impedance test can only be performed if the sensor temperature is at or above a minimum temperature of 1100°F with stable atmosphere present. The default minimum temperature is 1400°F . The instrument freezes all control functions and process signals during the test.

A 10K Ω resistor is shunted across the sensor output. The sensor impedance is calculated as:

$$R_x = [(E_o/E_s)-1]*R_s$$

Where R_x = sensor impedance, E_o = sensor's open circuit voltage, E_s = shunted sensor's voltage, and R_s = shunt resistor. The units of R_x are the same as R_s .

Sensor Burnoff

Sensor burnoff is performed by flowing air into and around the oxygen sensor internal ceramic substrate. This air creates a flame at the tip of the sensor that burns off any accumulated carbon or soot. A ¼" CPI compression fitting at the mounting hub of United Process Controls sensor is provided for the air connection. This air floods the sensor sheath and flows out and around the sensor. The sensor does have to be above the MIN PROBE TEMP parameter found in the PROBE setup menu. This value is typically 1300°F or higher.

To run a sensor burnoff it is necessary setup the sensor test parameters in the SETUP Probe Menu. Please refer to Sensor parameters table for an explanation of these setup parameters. It is necessary to have the burnoff (BOFF) test or both (BOTH) selected at the PROBE TEST parameter in order to run the burnoff. You may choose to accept the defaults for the other parameters in this menu or change them to suit your application. It is necessary that the sensor be above the MIN PROBE TEMP parameter setting for this test to run. It is not necessary for the sensor to be measuring a stable process gas during this test.

There are two ways to start this test. The first way to start the test is by pressing the ENTER and RIGHT ARROW keys at the same time when the display is showing the process values. The test can be stopped by pressing ENTER and RIGHT ARROW.

The second way to start the sensor test is to write a 1 to the PSTART (Probe Start) word in the instrument memory Block 3 Parameter 72 via the serial communications interface. Refer to the instrument memory map for details on the format of this word. The instrument will reset this value when the test starts and will ignore any changes while the test is running.

If the TEST INTEVAL parameter has a number other than 00.0 then the test will continue to run each time the test interval timer counts down to 0. This test interval can be stopped by setting the interval timer to 00.0.

Readings are averaged to eliminate variations in measurement due to initial flow conditions. There are three operator inputs for verification time periods;

- TEST INTERVAL is an interval timer that sets the time between automatic verifications in hours and tenths. The verification can be manually initiating by pressing and holding the Enter key and then the Right Arrow key. Setting the test interval time to zero disables automatic testing.
- BURNOFF TIME is the period in seconds burnoff air is flowing to the sensor.

- BURNOFF RECOVERY is the time period in seconds that allows the sensor to recover and return to the process level.

The following table outlines the actions the instrument takes at each sequence step.

Table 14 Sensor Burnoff Sequence

Sequence #	Description
1	Inhibit process variable calculations. Freeze all process controls and outputs.
	Freeze alarms at last state except clear any previous probe test failure alarm.
	Close burnoff contact and wait the BURNOFF time period.
2	Release the burnoff contact and wait the BURNOFF RECOVERY time period.
	Save the mV reading as in INFO menu.
3	Resume normal operation of all instrument functions.

Procedure to Test the Sensor

The following section describes the steps required to do an automatic or manual test of an oxygen sensor using the Versapro controller or monitor.

Set up parameters for the Probe Testing.

1. Press the **SETUP** key for five seconds to activate the setup mode
2. Page to the **Prob** Menu heading by pressing the RIGHT or LEFT arrow keys. When **Prob** appears in the LCD display, press the **Enter** key.
3. The first parameter is probe test. Press the UP or Down Arrow keys until the lower display reads **Both**. Press the **Enter** key to advance to the next parameter.
4. The next parameter is the Test Interval (hours). This should be set to **0** for a manual start test. A flashing cursor in the lower LED display indicates which digit can change if the parameter value is numeric. The UP or DOWN arrows increase or decrease the digit value. The RIGHT or LEFT arrow keys move the cursor to the right or left digit. If a number is entered here it is the interval in hours between automatic repeats of the probe test. The probe test must be started manually the first time to initiate the repeat function.
5. The next parameter is the Probe Impedance Limit. This should be set to **20 (Kohms)**. This setting is where the sensor electrodes are starting to wear and should be watched. If the impedance reaches 50 Kohms, the sensor should be replaced.
6. The next parameter is the Impedance Recovery Time (seconds). The default value is **30**. This value should always be greater than the millivolts filter value in the Input menu.
7. The next parameter is the Burnoff Time (seconds). The default value is **30**. This value typically should not exceed 60 seconds if burnoff is being done at regular intervals.

8. The next parameter is the Burnoff Recovery (seconds). The default value is **30**. This value may have to be increased if there is low re-circulation in the furnace.
9. The next parameter is the Minimum Probe Temperature. This should be set to **590** if C is used or **1100** if F is used.
10. After pressing the **ENTER** key for the last parameter, press the **SETUP** key to exit the Menu and return to regular process operation.

Manually start of probe test procedure

1. Simultaneously press the **RIGHT arrow/Enter** keys with the display in normal process mode.
2. The instrument will cycle through the test steps and return to normal operation after completing the test if results are satisfactory.
3. You may access the results by cycling the display with presses of the **Enter** key. If a probe fault alarm is displayed it will be necessary to go to the **Info** section of the **SETUP** Menu. The measured probe impedance, probe impedance test recovery time, probe millivolts and probe temperature during burnoff, and burnoff recovery time are listed.

If a Probe Fault occurs

To clear a Probe Fault alarm, you must run a successful probe test procedure, also see the Troubleshooting section of this document.

Access the Probe Test Results data from the **Info** section of the **SETUP** Menu. Check the probe impedance and recovery times against the parameter settings in the Probe setup section. If necessary, adjust the test parameters to allow a successful test. Take the necessary actions to correct the problem.

Tuning

Before attempting to tune the instrument make sure you understand the *Operation and Setup* part of the instrument.

What is tuning?

Tuning the controller means that the control characteristics of the controller are matched to those of the process in order to obtain hold the process to setpoint. Good control means:

- Stable, 'straight-line' control of the process variable at setpoint without fluctuation
- No (minimum) overshoot, or undershoot, of the process variable relative to setpoint
- Quick response to deviations from the setpoint caused by external disturbances, thereby rapidly restoring the process variable to the setpoint value.

Tuning involves calculating and setting the value of the parameters listed the following table. These parameters appear in the Control Setup menu.

Table 15

Parameter	Meaning or Function
Proportional band	The bandwidth, in display units, over which the output power is proportioned between minimum and maximum.
Integral time (Reset)	Determines the time taken by the controller to remove steady-state error signals.
Derivative time (Rate)	Determines how strongly the controller will react to the rate-of-change of the measured value.
Cycle Time	The total amount of time used to calculate the combination of percent on and percent off periods of the control function.

The Versapro uses the Proportional Band as a representation of the Proportion section of PID, the Reset as a representation of the Integral section of PID, and the Rate as a representation of the Derivative section of PID. Thus by following a simple procedure, PID tuning can easily be implemented in any control situation. A suggested procedure is diagramed in the next figure.

All of the PID parameters may be altered by changing these parameters in the Setup / Ctrl menu. The following procedure assumes the initial PID values for a typical batch furnace. You may be able to start with a proportional band setting of 10 or less for a smaller box or temper furnace.

You must determine what the initial cycle time should be. If you are using control motors or continuous motors, set the cycle time to the time it takes the control motor or actuator to fully open and fully close. If you are using quick acting solenoids to control the process the cycle time setting is a compromise between longer times to limiting contact cycles and extend the life of the actuator or shorter times to maintain good control. A good rule is to watch the process value and turn on the solenoid. Measure the time it takes for the process to react with a 5% change. Double this time and enter it as the cycle time. Decrease the cycle time to get a smoother control.

If, after following the procedure, the process continues to oscillate, it may be necessary to change the HIPO or LOPO parameters. Make sure that the control output is linear through the full range from LOPO to HIPO. In situations where the system is difficult to tune, it is most likely the output is not linear or there is too much lag time between the control command and measurable changes in the process. Test the system in manual mode to verify the output is linear.

A much higher proportional band may be necessary for extreme lag in the process response. In most cases, the derivative part of the control equation is not necessary. Generally, furnace control can be maintained using only the proportional band and the reset parameters.

Make sure you record all operating parameters and keep them in a secure place for later reference.

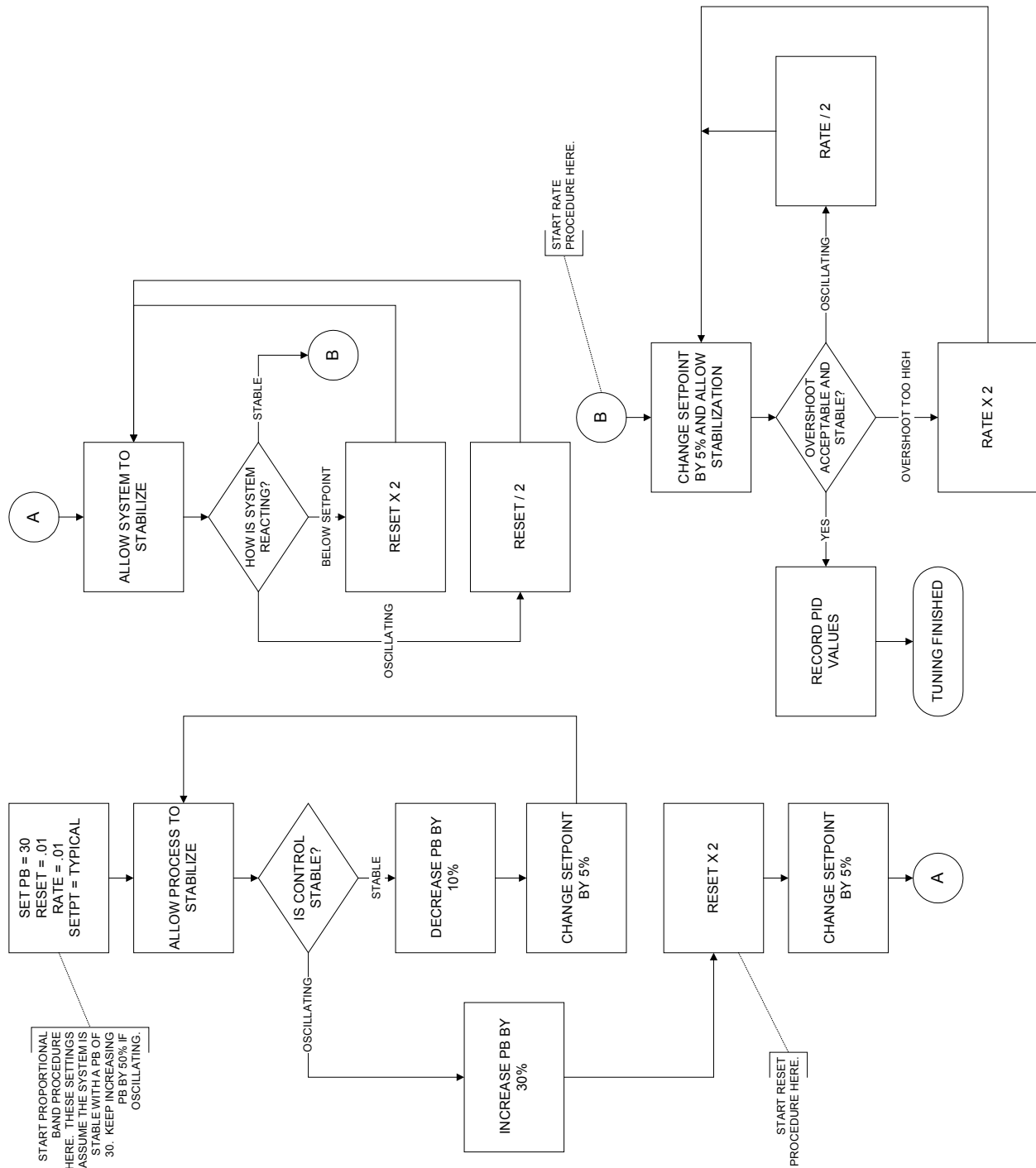

Figure 8 PID Manual Tuning Procedure

Scaling Analog Inputs

If the process is set to either linear input, the displayed value for that input can be scaled to desired engineering units. This is helpful if the measured linear value has to be scaled and re-transmitted on one of two analog output channels.

Using the equation $y = mx + b$, where

Y is the desired engineering unit to be displayed

X is the linear millivolt value

M is the Slope of the y/x relationship

B is the y intercept

Linear A Example

Let us use Input A input for a linear oxygen transducer that outputs a 0mV to 53.2mV signal for a 0% to 100% oxygen range. Since both the signal output and the process minimum are both 0, the Input A offset will be 0.

The slope can be calculated by dividing the maximum process value (100) by the maximum input level (53.2mV). This gives a slope value of 1.879. This number can be entered as the Input A slope. The decimal point can be shifted by placing the flashing cursor on the most significant digit and pressing the Left arrow key until decimal point shifts to the required position.

These scaling values will produce a process value of 100.0160% carbon for a maximum sensor input of 53.2mV. The process display can be configured to display either 100 or 100.0. This process value can then be retransmitted to other control devices are a recorder. The control model of the Versapro will be able to control to a set point for the new process value.

Keyboard Function during Input Slope

The four digits in the slope display can be change from 0 to 9 or the left digit and change to the negative sign. This most significant digit position also allows you to shift the decimal point by pressing the LEFT arrow key. The decimal point will shift from first digit to the third digit as the LEFT arrow key is pressed. Pressing the RIGHT arrow key when the cursor is on the least significant digit will shift the decimal point to the right.

Scaling Analog Outputs

The analog outputs are scaled as simple offset and span values. For example if analog output 1 is to be scaled for a 0 to 2.50% carbon value, the offset value would be 0 and the span value would be 2.50.

It is possible to narrow the range of the output even if the instrument can measure a larger process range. If a smaller range of carbon were to be retransmitted it is necessary to change the offset value to the lowest value to be retransmitted. The span would be set to the highest value. For example if a carbon span of .50% to 1.00% was to be retransmitted then the offset would be .50, the span would be 1.00. The full 4mA to 20mA output range would respond to this narrower range of carbon.

The same rules apply to analog output 2. The range of the offset and span numbers depends on the range of the process value that has been selected for either analog output.

Additional selections for Power Output and Program mode have fixed offset and span values. The power output offset and span values are fixed to the LOPO and HIPO values selected for the control outputs under the Setup Control menu.

The Program mode selection has a fixed offset of 0 and a fixed span of 4096. When this output mode is selected the analog output can only be changed by writing a value to either the DACV1 or DACV2 registers.

When the main process value such as carbon, dewpoint, etc. is retransmitted the analog source 'Proc' should be selected. If the process source is set to either Lin A or Lin B then Lin A or Lin B analog sources should be selected to output the scaled value of either linear input.

Linear A is typically the thermocouple input for most applications does not respond if a control process requiring temperature is selected. The analog source 'TENP' (temperature) should be selected in these cases. Linear B can re-transmit the sensor millivolts for all process selections requiring an oxygen sensor.

Calibration

The Versapro has two analog inputs, a cold junction compensation sensor, and two analog outputs. The input levels are determined by which terminals are used for the input signal. There are two pairs of input terminals: TB-B 1, 2, typically for the thermocouple (T/C) input, and TB-B 3, 4, typically for the probe millivolt input.

The 4 – 20mA analog outputs are at TB-B 5, 6 and TB-B 7, 8.

The following is a brief description of input/output and its specifications.

- | | | | |
|----|----------------|-----------------|---|
| a) | T/C Input | Input range | -10 to +70 millivolts \pm 2 μ V |
| | | TC burnout | >full scale |
| b) | Probe mV Input | Input range | -50 to +2000 millivolts \pm .1 mV, linear |
| | | Input impedance | 40 megohm |
| | | Open input | >full scale |
| c) | Output 1 | Output range | 0 to 20 milliamps |
| | | Max. Load | 650 ohms |
| d) | Output 2 | Output range | 0 to 20 milliamps |
| | | Max. Load | 650 ohms |

Calibration Displays and Keyboard Operation

When entering the Calibration Menu, the operator has to answer one of two questions depending on which inputs or outputs have to be calibrated. If the CALIBRATION IN prompt is answered with a YES, the parameters related to the thermocouple input, millivolt input, and cold junction can be changed. If this prompt is skipped by pressing the Enter key, a second prompt, CALIBRATION OUT is displayed. If this prompt is answered with a YES, the zero and span values for both analog outputs can be changed.

In the Calibration Menu the displays and front panel keys take on special assignments. The LCD display shows the input and calibration point being calibrated. The upper LED display indicates that the instrument is in CAL mode. The lower LED display indicates the actual input level for the input channels or the calibration factor for the output channels.

It is very important that the display is indicating the proper I/O parameter before making an adjustment or the wrong value will be changed.

For the CAL INPUT calibration mode, the following keys perform the described functions:

<u>Key</u>	<u>Function</u>
UP ARROW	Increases the displayed value.
DOWN ARROW	Decreases the displayed value.
RIGHT ARROW	Shifts the flashing digit to the right and decreases the amount of adjustment or sensitivity of the adjustment.
LEFT ARROW	Shifts the flashing digit to the left and increases the amount of adjustment or sensitivity of the adjustment.
ENTER	Advances to next input value and saves the calibration changes.
SETUP	Exits the calibration mode.

Preparing for Input Calibration

The thermocouple calibration can be done in several ways depending on the type of calibrator available, the selected process source, and the cold junction setting. If the process source has been set to LInA (input A) then the displayed values for offset and span will be the direct millivolt inputs. If the process source is selected as carbon, dew point, oxygen, or temperature then the display values will be in temperature. When in temperature mode, this reading can also be affected by the cold junction. If cold junction is not applied then the cold junction adjustment has no

affect and the temperature reading is not compensated. If cold junction is applied then the cold junction correction is applied to the zero, span, and cold junction adjustment values and the cold junction adjustment will have an effect on the temperature reading.

These methods of calibrating the temperature input can be used in situations where only one type of calibrator is available or in the field where a compensated thermocouple source is the most likely source. If an uncompensated thermocouple source is used then the connection to the instrument should be with copper wire and the cold junction compensation should be turned off.

The following items are required to calibrate thermocouple and millivolt inputs depending on the type of thermocouple input configuration.

- Calibrated millivolt source, 0 – 2000mV with a 0.1 mV resolution (input B)
- Calibrated millivolt source, -10mV to 50mV with a 0.1 uV resolution (input A linear mode).
- Copper wire to connect the millivolt source to the instrument (input A linear mode or CJ non compensated).
- Calibrated thermocouple simulator with internal cold junction compensation (process mode with CJ compensation).
- Thermocouple extension wire for the type of thermocouple to be used (process mode with CJ compensation).

Calibration of Temperature and Cold Junction

There are several ways to calibrate the temperature input depending on the circumstances. If the temperature varies by a few degrees from a thermocouple source then it may be possible to only adjust the CJ ADJUSTMENT found in SETUP, CAL IN menu. To do this, go into calibration mode, select YES for Cal Input and press Enter at TC Zero and TC Span. At CJ ADJUSTMENT correct the temperature reading by pressing the Up or Down arrow keys. Press SETUP to escape calibration mode.

For a complete calibration it is necessary to have a millivolt source with copper wire and a cold junction compensated source using the correct thermocouple extension wire. Use the following procedure for a full thermocouple calibration.

Calibration procedure:

1. Go into SETUP mode and select Ctrl menu, press Enter and select the required process such as carbon or dewpoint.
2. Press Rem to return to the top of the menu. Press the Right arrow to go to the INPUT menu. Press Enter to verify the thermocouple type and set APPLY CJ to NO.
3. Use a millivolt source with copper wire. Connect the wire to TB-1(+) and TB-2(-).
4. Set the source output for the equivalent zero millivolt level for the thermocouple setting.

5. Press Rem to return to the top of the menu. Press the Left arrow to get to the CAL menu. Press Enter to go to CAL IN and select Yes. Press Enter to get to thermocouple zero.
6. Adjust the Zero display to match the corresponding zero temperature value and press Enter to go to thermocouple span.
7. Set the source output for the equivalent span millivolt level for the thermocouple setting.
8. Adjust the Span display to match the corresponding span temperature value.
9. Press Rem to return to the top of the CAL menu. Press the Left arrow to go to INPUT menu. Press Enter to change APPLY CJ to Yes. Return to the CAL IN menu, CJ ADJUSTMENT.
10. Connect the thermocouple extension wire for the type of thermocouple selected and set the calibrator to the thermocouple span value.
11. Adjust the CJ Adjustment display to match the source temperature value.

Refer to the following tables for the equivalent millivolt level and temperature range.

Table 16 Thermocouple Calibration Values

T/C type	Zero Temperature °F (°C)	Zero Millivolt Equivalent	Span Temperature °F(°C)	Span Millivolt Equivalent
B	800 (426.7)	0.898	3000 (1648.9)	11.835
E	32(0.0)	0.000	1830 (998.9)	76.289
J	32 (0.0)	0.000	1400 (760.0)	42.919
K	32 (0.0)	0.000	2500 (1371.1)	54.856
N	32 (0.0)	0.000	2300 (1260.0)	46.060
R	300 (148.9)	1.032	3000 (1648.9)	19.525
S	300 (148.9)	1.021	3000 (1648.9)	17.353
T	32 (0.0)	0.000	700 (371.1)	19.097

The usable ranges for the thermocouple types are shown in the following table. If it is desirable to have a higher accuracy over a specific operating range then the input should be calibrated over that range.

Table 17 Usable Thermocouple Range (°F)

T/C type	Minimum Value (°F)	Maximum Value (°F)
B	800	3270
E	-440	1830
J	-335	1400
K	-340	2505
N	-325	2395
R	300 *	3210
S	300 *	3210
T	-380	755

* Due to the extreme non-linearity of low level signals, using type R and S below 300° F is not recommended.

Calibration of the Thermocouple Input (linear mode)

Calibration procedure:

1. Connect terminals TB-B 1, 2 to an isolated, stable millivolt source calibrator using standard copper wire, 20 AWG is sufficient.
2. Set the calibrator output to 0.00 mV.
3. Set the process source to LinA and activate the calibration mode by entering the calibration SETUP menu and changing Calibration IN - NO to YES.
4. Use the Enter key to select the TC ZERO mode.
5. Using the arrow keys, adjust the displayed value to equal the calibrator input.
6. Press the Enter key to select the TC SPAN mode.
7. Set the calibrator output to 50.0mV (70mV maximum).
8. Using the arrow keys, adjust the displayed value to equal the calibrator output.

Calibration of the Probe Millivolt Input

Calibration procedure:

1. Connect terminals TB-B 3, 4 to an isolated, stable millivolt source calibrator using standard copper wire, 20 AWG is sufficient. The input can respond to a maximum 2000 mV .
2. Set the calibrator output to 0.00 mV.
3. Activate the calibration mode by entering the SETUP menus, selecting the Calibration menu and changing Calibration IN - NO to YES.
4. Use the Enter key to select the MV ZERO mode. Set the calibrator output to 0.00mV.
5. Using the arrow keys, adjust the process value to equal the calibrator input.
6. Press the Enter key to select the MV SPAN mode.
7. Set the calibrator output to the required millivolt span (2000 mV maximum).
8. NOTE: The displayed number will change in resolution. The millivolt value will show the tenths digit if the measured value is less than 1000 mV. Above 999.9 mV the display will shift to whole numbers. Use the arrow keys to adjust the process value to equal the calibrator output.

Preparing for Analog Output Calibration

The same calibration procedure can be used for either output channel. For the CAL OUTPUT mode, the following keys perform the described functions:

<u>Key</u>	<u>Function</u>
UP ARROW	Increases the value of the flashing digit.
DOWN ARROW	Decreases the value of the flashing digit.
RIGHT ARROW	Shifts the flashing digit to the right.
LEFT ARROW	Shifts the flashing digit to the left.

ENTER Advances to next calibration value and saves the calibration changes.

SETUP Exits the calibration mode.

Note: If a mA meter is not available it is possible to calibrate using a volt meter and a resistor. For direct readings in voltage a precision 100 ohm resistor is recommended. Connect the resistor across the two terminals of either output channel. Connect the volt meter to the leads of the resistor. If a 100 ohm resistor is used, there will be a 0.400V reading for the zero output for an analog output. For a span output a voltage of 2.0V will be displayed.

Calibration procedure:

1. Connect terminals TB-B 5, 6 (or 7, 8) to a multimeter such as a Fluke 77. Select the milliamp measurement range and verify that the test leads are plugged into the milliamp jack and common on the multimeter.
2. Activate the calibration mode by entering the SETUP menu, selecting the Calibration menu, press the ENTER key until CAL OUTPUT - NO is displayed.
3. Change the NO prompt to YES using the UP arrow key.
4. Press the ENTER key to select the OUTPUT 1 MIN mode. If OUTPUT 2 is required, continue pressing the ENTER key until OUT 2 MIN is displayed.
5. Using the UP or DOWN arrow keys, adjust the displayed number from 0 to 9. Press the RIGHT or LEFT arrow keys to select the adjustment sensitivity. Adjust the displayed value until the multimeter indicates the desired minimum output. This is typically set for 4 mA (cal factor ~ 800), but this level can be adjusted to 0mA (cal factor ~ 0).
6. Press the ENTER key to select the OUTPUT 1 SPAN mode. If OUTPUT 2 is required, continue pressing the ENTER key until OUTPUT 2 SPAN is displayed.
7. Using the arrow keys as explained in step 5, adjust the output to read 20mA on the multimeter. A typical cal factor for 20mA is 3200. The maximum cal factor is 4095.
8. Press the SETUP key to save the calibration values and exit the calibration routine.

Communications

Modbus

The MODBUS protocol describes an industrial communications and distributed control system (DCS) that integrates PLCs computers, terminals, and other monitoring, sensing, and control devices. MODBUS is a Master/Slave communications protocol, whereby one device, (the Master), controls all serial activity by selectively polling one or more slave devices. The protocol provides for

one master device and up to 247 slave devices on a half duplex twisted pair line. Each device is assigned an address to distinguish it from all other connected devices.

The VersaPro recognizes three Modbus RTU (Remote Terminal Unit) commands. These are: read single I registers (command 4), read a single H register (command 3), and preset a single H register (command 6)

In the RTU protocol sends data in 8-bit binary characters. Message characters are transmitted in a continuous stream. The message stream is setup based on the following structure:

Number of bits per character:

Start bits	1
Data bits (least significant first)	8
Parity	0 (no bits for no parity)
Stop bits	1 or 2
Error Checking	CRC (Cyclical Redundancy Check)

In Modbus mode, the VersaPro can be only be configured for the 'none' parity option.

The instrument never initiate communications and is always in the receive mode unless responding to a query.

RTU Framing

Frame synchronization can be maintained in RTU transmission mode only by simulating a synchronous message. The instrument monitors the elapsed time between receipt of characters. If three and one-half character times elapse without a new character or completion of the frame, then the instrument flushes the frame and assumes that the next byte received will be an address. The follow command message structure is used, where T is the required character delay. Response from the instrument is based on the command.

T1,T2,T3	ADDRESS	FUNCTION	DATA	CHECKSUM	T1,T2,T3
	8-BITS	8-BITS	N X 8-BITS	16-BITS	

Address Field

The address field immediately follows the beginning of the frame and consists of 8-bits. These bits indicate the user assigned address of the slave device that is to receive the message sent by the attached master.

Each slave must be assigned a unique address and only the addressed slave will respond to a query that contains its address. When the slave sends a response, the slave address informs the master which slave is communicating.

Function Field

The Function Code field tells the addressed slave what function to perform. MODBUS function codes are specifically designed for interacting with a PLC on the

MODBUS industrial communications system. Command codes were established to manipulate PLC registers and coils. As far as the VersaPro is concerned, they are all just memory locations, but the response to each command is consistent with Modbus specifications.

The high order bit in this field is set by the slave device to indicate an exception condition in the response message. If no exceptions exist, the high-order bit is maintained as zero in the response message.

Data Field

The data field contains information needed by the slave to perform the specific function or it contains data collected by the slave in response to a query. This information may be values, address references, or limits. For example, the function code tells the slave to read a holding register, and the data field is needed to indicate which register to start at and how many to read.

Error Check Field (CRC)

This field allows the master and slave devices to check a message for errors in transmission. Sometimes, because of electrical noise or other interference, a message may be changed slightly while it is on its way from one device to another. The error checking assures that the slave or master does not react to messages that have changed during transmission. This increases the safety and the efficiency of the MODBUS system.

The error check field uses a CRC-16 check in the RTU mode.

The following is an example of a function 03 call for timer setpoint value (TSETPT) at memory location 03. The value returned by the instrument is the hex value 1E (30 seconds).

Transmit from Host or Master

Address	Cmd	Reg HI	Reg LO	Count HI	Count LO	CRC HI	CRC LO
01	03	00	03	00	01	74	0A

Response from Versapro

Address	Cmd	Byte Count HI	Byte Count LO	Data HI	Data LO	CRC HI	CRC Lo
01	03	00	02	00	1E	38	4C

Note that all the values are interpreted as hexadecimal values. The CRC calculation is based on the A001 polynomial for RTU Modbus. The function 04 command structure is similar to the 03 structure.

The following is an example of a function 06 call to change the remote setpoint (RSETPT) to 200 (2.00%). The response from the instrument confirms the new value as being set.

Transmit from Host or Master

Address	Cmd	Reg HI	Reg LO	Data HI	Data LO	CRC HI	CRC LO
01	06	00	01	00	C8	D9	9C

Response from Versapro

Address	Cmd	Reg HI	Reg LO	Data HI	Data LO	CRC HI	CRC LO
01	06	00	01	00	C8	D9	9C

The Versapro will respond to several error conditions. The three exception codes that will generate a response from the instrument are:

- 01 – Illegal Function
- 02 - Illegal Data Address
- 03 – Illegal Data Value
- 04 – Slave Device Failure

The response from the Versapro with an exception code will have the most significant bit of the requested function set followed by the exception code and the high and low CRC bytes.

MMI Message Protocol

The basic United Process Controls message protocol format is shown below.

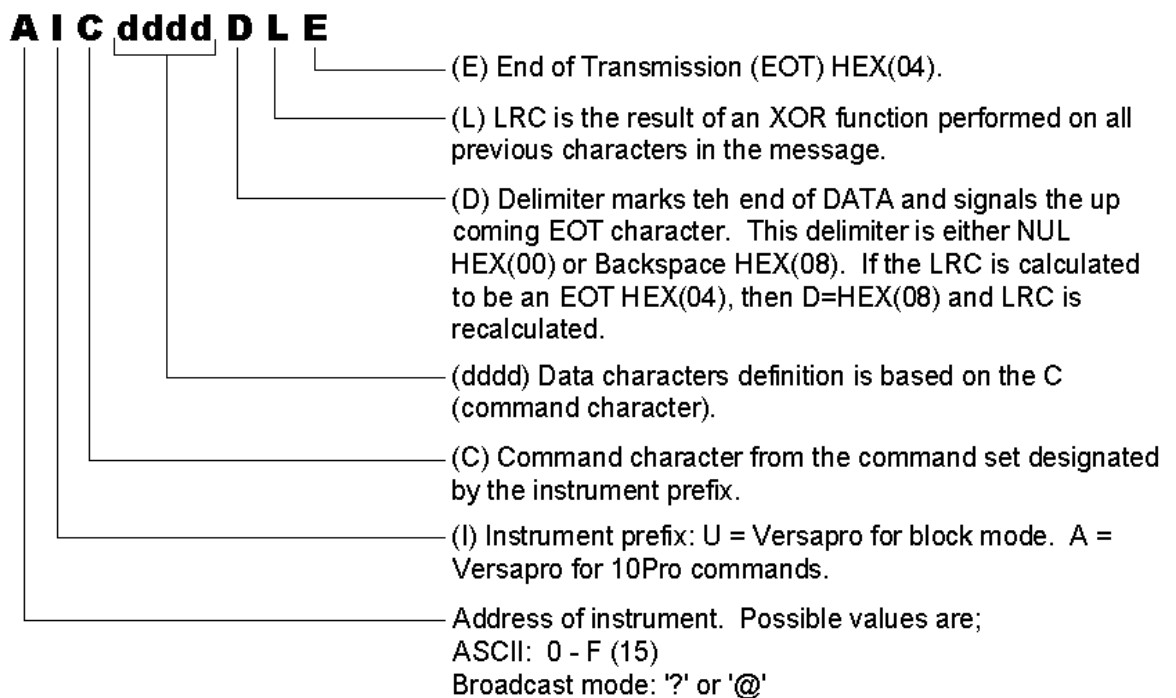

As indicated, the MMI or proprietary mode allows communication using the 10PRO 'A' command protocol or the 'U' block protocol.

The following command set applies to the 'A' command and is used for the Versapro and other 10PRO type instruments such as temperature controller slaves. The command set is sent by a master to a 10PRO slave instrument. These commands can also be used by any device such as a computer communicating with instruments via an instrument network. The commands that are supported are shown in the following table.

Table 18 10Pro / 10Pro-T Command Set

COMMAND LETTER	Process (temperature)	Timer	Returned Value
p (low case)	Read Auto / Manual mode	Same	A = auto, B = manual
o (low case)	Read Remote / Local	Same	A = local, B = remote
i (low case)	Read Remote Process Setpoint	Read Remote Time Setpoint	integer decimal number
h (low case)	Read Auto Process Setpoint	Read Auto Time Setpoint	integer decimal number
I (upper case as in Instrument)	Update Process Setpoint Temporarily	Update Time Setpoint Temporarily	integer decimal number
J (upper case)	Update Process Setpoint Permanently	Update Time setpoint Permanently	integer decimal number
I (lower case as in limits)	Read Actual Process	Read Remaining Time	integer decimal number
m (low case)	Read % Output	Read Time control byte	integer decimal number
P (upper case)	Update Auto/Manual mode	Same	A = auto, B = manual

The following are examples of commands and responses using the 10Pro type command set. The first row in each table shows the ASCII characters of the command as they would appear if monitored on the serial port. The second row in each table is the hexadecimal translation of the characters transmitted on the serial port. These values must be known to calculate the checksum.

This is the command and response for reading the actual process value of a 10Pro type slave instrument. In this example the 10Pro instrument address is 2 and the return value is 0071. This could be 71 degrees, 0.71% carbon, 7.1 degrees dewpoint, or 0.71% oxygen depending on the process and the instrument settings. Other parameters and scaling are available if the linear inputs are selected. In general the number that is returned is the number displayed on the instrument. Decimal point information is assumed.

Transmit from Host or Master

Add	Prefix	Cmd	Delim	LRC	
2	A	I	<NULL>	<HEX 1F >	<EOT>
0x32	0x41	0x6C	0x00	0x1F	0x04

Response from 10Pro

	Add	Prefix	Cmd	D1	D2	D3	D4	Delim	LRC	
<ACK>	2	A	l	0	0	7	1	<NULL>	<HEX 1F >	<EOT>
0x06	0x32	0x41	0x6C	0x3 0	0x3 0	0x3 7	0x3 1	0x00	0x1F	0x04

Here is an example of a request and response for the local setpoint of the instrument in Automatic mode. The response indicates that the instrument's address is 2 and the local setpoint is 1500.

Transmit from Host or Master

Add	Prefix	Cmd	Delim	LRC	
2	A	h	<NULL>	<HEX 1B >	<EOT>
0x32	0x41	0x68	0x00	0x1B	0x04

Response from 10Pro

	Add	Prefix	Cmd	D1	D2	D3	D4	Delim	LRC	
<ACK>	2	A	H	1	5	0	0	<NULL>	<HEX 19 >	<EOT>
0x06	0x32	0x41	0x68	0x3 1	0x3 5	0x3 0	0x3 0	0x00	0x19	0x04

Here is an example that shows how the HOST changes the instrument's remote set point. The instrument's address is 15. The HOST has sent a command to update the remote setpoint with 1450. The instrument responds by echoing the command.

Transmit from Host or Master

Add	Prefix	Cmd	D1	D2	D3	D4	Delim	LRC	
F	A	l	1	4	5	0	<NULL>	N	<EOT>
0x46	0x41	0x49	0x3 1	0x3 4	0x3 5	0x3 0	0x00	0x4E	0x04

Response from 10Pro

	Add	Prefix	Cmd	D1	D2	D3	D4	Delim	LRC	
<ACK>	F	A	l	1	4	5	0	<NULL>	H	<EOT>
0x06	0x46	0x41	0x49	0x3 1	0x3 4	0x3 5	0x3 0	0x00	0x48	0x04

Instrument Type 'U' Command Set

The MMI (United Process Controls Inc.) command set supports the extensive capabilities of the Dualpro the 10Pro-E and the Versapro. The command set consists of the characters shown in the following table.

Table 19 MMI Command Set

Update	Read	Description
X	x	Read / Writer Table Parameters

Not Allowed	*	Read Block Transfer
-------------	---	---------------------

'X' Command

The 'X' command allows almost unlimited access to all the instrument parameters. The 'X' command accesses the various parameter tables in the instrument. A typical parameter table for most Marathon instruments has 240 parameters numbered consecutively from 0 to 239 (0 – 0xEF). Instruments such as the Dualpro have many tables (0 – 31), where each table has 11 blocks or more.

The Versapro, 10Pro-E, and Version 3.5 Carbpro have only table 0. The table value is assumed to be 0 and the parameter is addressed directly with the possible range of 0 to 71. These numbers correspond with the decimal numbers in the Versapro Memory Map table.

To READ a data value from a table / parameter number in the instrument, use the following format:

AUx (Table # Parameter #) <delimiter> <checksum> <EOT>

Here is an example of a request and response for the instrument's proportional band setting in table 0, parameter 10 (0x0A). The instrument address is 1. The data value that is returned by the instrument is hexadecimal 0014 or 20.

Transmit from Host or Master

Add	Prefix	Cmd	Table #	Par #	Delim	LRC	
1	U	x	00	0A	NULL	<HEX 6D >	EOT
0x31	0x55	0x78	0x30 0x30	0x30 0x41	0x00	0x6D	0x04

Instrument Response

	Add	Prefix	Cmd	Table #	Par #	Data Delim	D1	D2	D3	D4	Delim	LRC	
<ACK>	2	U	x	00	0A	\$	0	0	1	4	<NULL>	J	<EOT>
0x06	0x32	0x55	0x78	0x30 0x30	0x30 0x41	0x24	0x30	0x30	0x31	0x34	0x00	0x4A	0x04

The response from the instrument includes the '\$' character. This character acts as the data delimiter, which separates the parameter data from the parameter address.

Here is an example of a request and response for the instrument's Alarm 1 value in table 00 (0x00) parameter 06 (0x06). The instrument address is 1. The data value that is returned by the instrument is 50 (0x32). The actual value is 0.50 where the decimal point is implied by the process.

Transmit from Host or Master

Add	Prefix	Cmd	Table #	Par #	Delim	LRC	
1	U	x	00	06	NULL	1A	EOT
0x31	0x55	0x78	0x31 0x30	0x31 0x33	0x00	0x1A	0x04

Response from Instrument

	Add	Prefix	Cmd	Table #	Par #	Data Delim	D1	D2	D3	D4	Delim	LRC	
<ACK>	1	U	x	00	06	\$	0	0	3	2	<NULL>	9	<EOT>
0x06	0x31	0x55	0x78	0x30 0x30	0x30 0x36	0x24	0x30	0x30	0x33	0x32	0x00	0x39	0x04

The parameter write command uses the following format:

AUX (Table # Parameter #) \$ data <delimiter> <LRC> <EOT>

To write a value to the instrument for a specific parameter use the uppercase X. To read a specific parameter from the instrument, use the lowercase x.

Here is an example of a parameter write command and response for data in table 00 (0x00) parameter 06 (0x06). The instrument address is 1. The data value that is written to the instrument is 0000 (0x0000).

Transmit from Host or Master

Add	Prefix	Cmd	Table #	Par #	Data Delim	D1	D2	D3	D4	Delim	LRC	
1	U	X	00	06	\$	0	0	0	0	NULL	1E	EOT
0x31	0x55	0x58	0x30 0x30	0x30 0x36	0x24	0x30	0x30	0x30	0x30	0x00	0x1E	0x04

Response from Instrument

	Add	Prefix	Cmd	Table #	Par #	Data Delim	D1	D2	D3	D4	Delim	LRC	
ACK	1	U	X	00	06	\$	0	0	0	0	NULL	18	EOT
0x06	0x31	0x55	0x58	0x30 0x30	0x30 0x36	0x24	0x30	0x30	0x30	0x30	0x00	0x18	0x04

The parameters for the Versapro are listed in the manual appendix. This listing includes the parameter name, number, and a short description that includes bit and byte mapping information.

Block Commands

Block transfer commands are used to read and write data in a group of 24 words. The Versapro has only three blocks in table zero. The block transfer command has to identify the table as well as the block.

A block read command format is shown below.

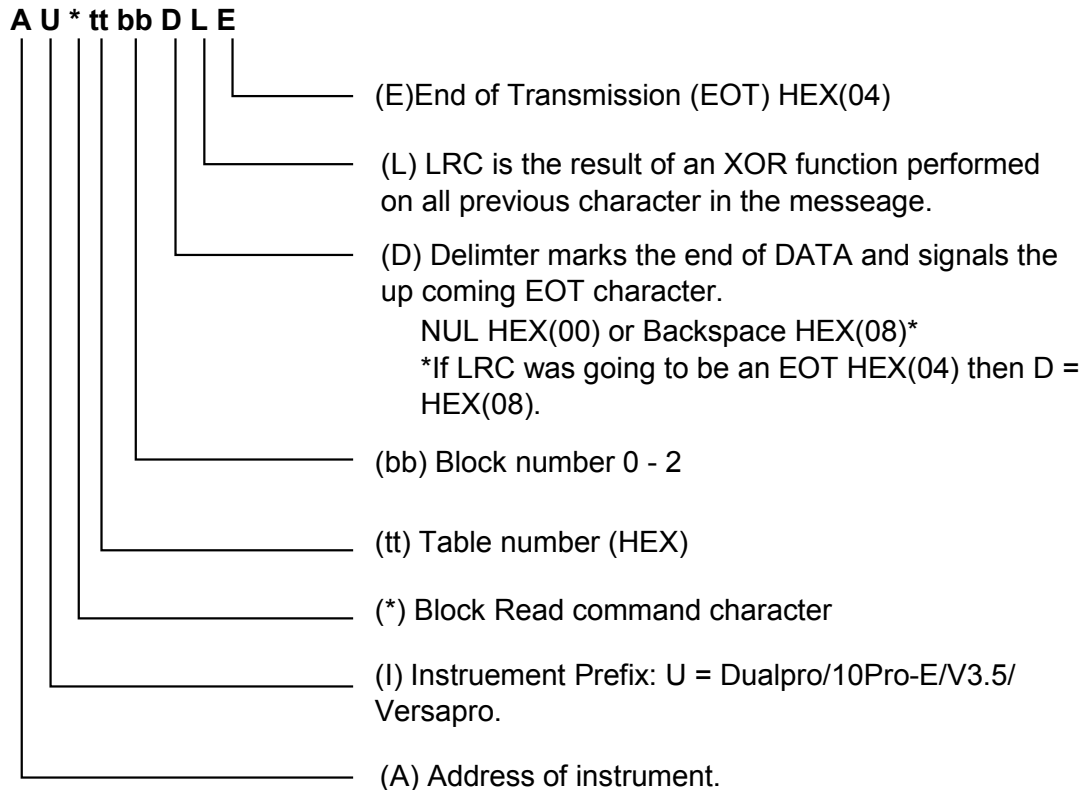

Figure 9 Block Read Command Format

The reply to a Block read request follows.

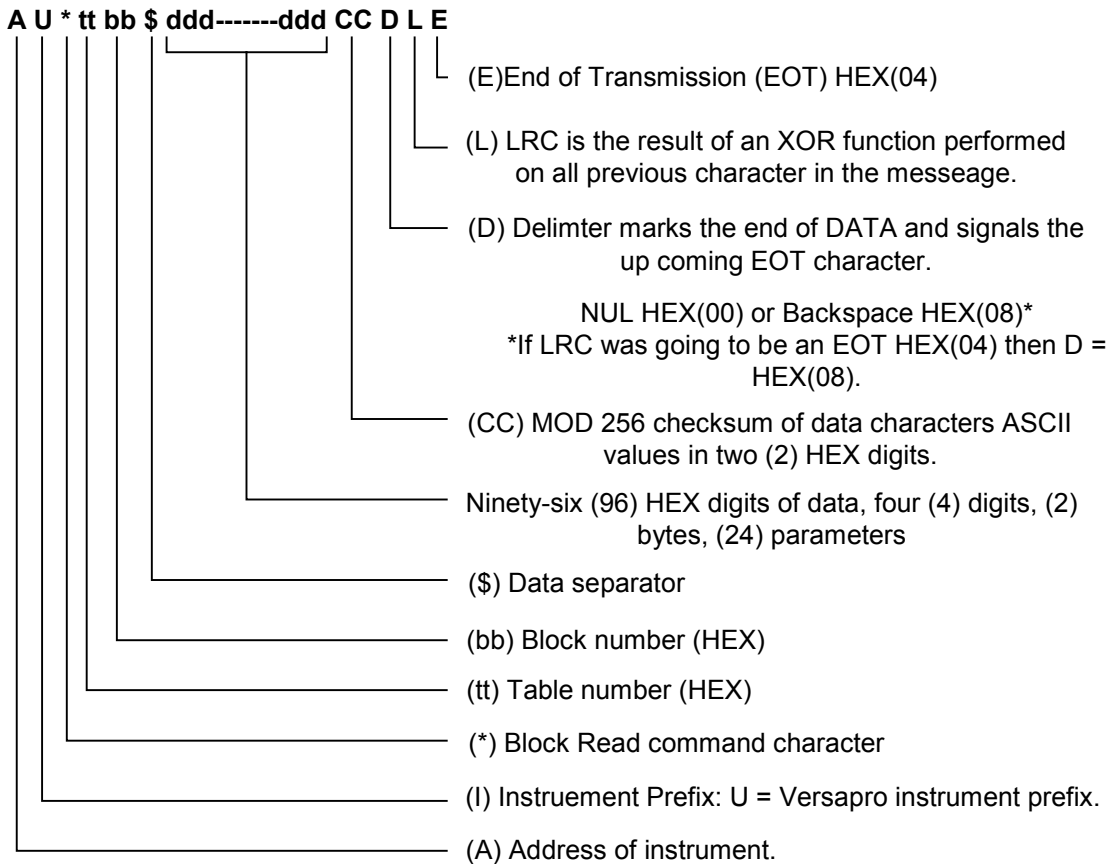

Figure 10 Block Read Response Format

The following is an example is for a block request from the Host and a reply from the instrument. The Host sends the command:

1U*0000<00>N<04><06>

Where the instrument address is '1', the instrument type is 'U', the table and block are both zero (TTBB), and the delimiter, LRC and EOT follow.

The instrument responds with the string shown in the following table.

Table 20 Sample Block Response

	Hex	ASCII
Address	1	31
Type	U	55
Command	*	2A
Register	0000	30 30 30 30
Delimiter	\$	24
Parameter 1	C11C	43 31 31 43
Parameter 2	00E5	30 30 45 35
Parameter 3	8112	38 31 31 32

Parameter 4	0096	30 30 39 36
Parameter 5	0096	30 30 39 36
Parameter 6	00C8	30 30 43 38
Parameter 7	03B6	30 33 42 36
Parameter 8	07D0	30 37 44 30
Parameter 9	0000	30 30 30 30
Parameter 10	0C00	30 43 30 30
Parameter 11	03E8	30 33 45 38
Parameter 12	03E8	30 33 45 38
Parameter 13	0000	30 30 30 30
Parameter 14	0000	30 30 30 30
Parameter 15	0000	30 30 30 30
Parameter 16	0000	30 30 30 30
Parameter 17	0060	30 30 36 30
Parameter 18	1C25	31 43 32 35
Parameter 19	00F3	30 30 46 33
Parameter 20	3C69	33 43 46 39
Parameter 21	0001	30 30 30 31
Parameter 22	03E8	30 33 45 38
Parameter 23	0000	30 30 30 30
Parameter 24	3D62	33 44 36 32
MOD 256	BF	42 46
Delimiter	00	00
LRC	1B	1B
EOT	04	04

Note that the MOD 256 is the 256 modulus of the sum of the ASCII values of the parameters. The delimiter and LRC are calculated as described in a previous section.

MMI Error Codes

The Marathon protocol for the Versapro has three error codes that can be generated by the instrument: E1 = Incorrect LRC detected on received message, E2 = Invalid command detected, and E3 = Invalid table or parameter address.

The format for the error message is

<NAK> Error Code DEL LRC <EOT>

Where <NAK> is the hexadecimal value 15 followed by the ASCII characters for the appropriate error code. The delimiter and LRC are calculated the same as for a normal message. The EOT (hexadecimal 04) end every message in the MMI protocol.

Process Calculation

Percent Carbon

The carburizing activity in a furnace are such that when equilibrium between carbon monoxide and oxygen exists, then the carbon potential of the atmosphere is fixed at a value determined by the relative amounts of these two gases. Assuming that the

carbon monoxide content of the atmosphere does not vary significantly, then the carbon potential will depend mostly upon the oxygen content of the atmosphere.

The oxygen in the atmosphere is measured by a technique that exposes an in-situ zirconia-platinum sensor to the gas. A millivolt signal generated by this sensor is transmitted to a controller for processing. Also transmitted is the atmosphere temperature by virtue of a thermocouple located in or near the oxygen sensor. Assuming that the oxygen and carbon monoxide are in equilibrium and that the carbon monoxide level does not vary significantly, we now have all the information required to produce an approximate calculation of %C in the atmosphere.

The equation used as the basis for the controller's calculation of %C is:

$$\%C = \frac{(5.102) \text{EXP} \left[\frac{E - 786}{.0431 T} \right]}{\frac{.2}{P_{\text{CoM}}} \times \frac{945.7(\text{af})}{P_{\text{CoA}}} + \text{EXP} \left[\frac{E - 786}{.0431 T} \right]}$$

Where:

E = oxygen probe output millivoltage

T = temperature of atmosphere (Kelvin)

P_{CoA} = assumed partial pressure of carbon monoxide in atmosphere (= %CO/100 at 1 atm. pressure)

P_{CoM} = measured partial pressure of carbon monoxide in atmosphere (= %CO/100 at 1 atm. pressure)

af = alloy factor for a given steel (Close to 1 for most carburizing steels); can be calculated from the equation:

af (for low-alloy steels only) =

$$\begin{aligned} &1 + \%Si(.15 + .033\%Si) + .0365(\%Mn) \\ &- \%Cr(.13 - .0055\%Cr) + \%Ni(.03 + .00365\%Ni) \\ &- \%Mo(.025 + .01\%Mo) - \%Al(.03 + .002\%Al) \\ &- \%Cu(.016 + .0014\%Cu) - \%V(.22 - .01\%V) \end{aligned}$$

It should be noted that if the Carbon Monoxide content of the furnace is not known, the term in the equation involving af and P_{Co} can be thought of as a single, overall constant for a given set of furnace and load conditions. For typical endo gas it is also assumed that P_{Co} is 20% Carbon Monoxide. It is for this reason that this term was chosen as the location for the "Process Factor" adjustment in the Carbon Controller. Mathematically, the "Process Factor" adjustment as entered on the front panel for a given case relates to the term in the above equation as follows:

$$29(\text{PF}) + 400 = \frac{945.7 \text{ af}}{P_{\text{Co}}}$$

Where:

PF = Process Factor (0-999) and

Pco = partial pressure of carbon monoxide in atmosphere, assumed to be 20%

Adjustment of the Process Factor by the user will allow compensation to be made for a wide range of conditions. A nominal 20% carbon monoxide methane-based endothermic gas atmosphere, with an assumed alloy factor of 1 would require a Process Factor of 149. If a propane-based endothermic (23% carbon monoxide), would require a Process Factor of 128. For nitrogen-methanol systems, the Process Factor used will be the same as for methane-based endo atmosphere. However, this will depend entirely on the ratio of methanol to nitrogen and some experimentation would be required to arrive at a working value. Note that for pure methanol, the theoretical process factor would be 85. Note also that if high-nickel steels such as 3115 are to be accurately carburized, an alloy factor (af) will be important in determining the correct Process Factor. Process factors for high alloy steels such as tool steels are not directly calculable because of carbide interaction. These must be arrived at experimentally.

As a practical matter, the correct Process Factor for a given set of circumstances is best determined from experimentation with shim stock and/or carbon test bars; the above equations may then be used as a basis for correcting the factor from a mathematical standpoint. It is usually easier, however, to correct the Process Factor in real-time by simply changing its value and observing the results in the %C display in relation to a known %C in the furnace. When using this method care must be taken to gather enough solid data before making adjustments. Not allowing for statistical variations between loads can be a potential cause of serious error in setting up a Process Factor.

If a significantly different Process Factor than seems logical must be used to get a correct %C display, a number of things must be investigated. The necessity of using a relatively high Process Factor can possibly be taken to mean that soot is present in the furnace, or that the oxygen probe is incorrectly located, or that the probe is sooted. A low value for Process Factor might indicate a problem with reference air supply to the probe or impending failure of the probe altogether.

The Versapro Carbon controller has two ways to correct the carbon reading; the Process Factor and the CO Compensation value. It is recommended that only one correction method is used depending on the circumstances of the process. Typically the Process Factor is used to make a carbon correction with the assumption that CO is 20%. The default for the Process Factor is 150 and the default for CO Compensation is 20.

It is possible to make carbon correction directly with changes in CO if the system has a CO analyzer. This information can be written digitally to the Versapro from a Master instrument that is also monitoring or controlling the infrared gas analyzer. See the section on Communications for details. If the CO Compensation is used as the process variable it is recommended that the Process Factor not change.

Dew Point

The dew point calculation is based on an endothermic atmosphere in equilibrium with the assumptions of 40% hydrogen and an initial process factor of 150.

$$\text{Dewpoint} = \frac{4238.7}{9.55731 - \log_{10}(E / (T_k \times 0.0215))}$$

Where:

E = probe millivolts + mv offset, T_k = probe temperature in degrees Kelvin.

NOTE:

This calculation is only valid for Endothermic Rx gas in a state of equilibrium. The equation will not work for a dew point calculation on Exothermic gases. Other types of processes will require empirical analysis.

Troubleshooting Questions

This section is organized alphabetically by the functional name of various instrument operations and features. Some explanations may be listed in more than one category since the problem can be approached from several different points of view. Each problem is presented as a question for typical problems that may be encountered. In most cases the problem can be resolved by changing a setup parameter in the instrument.

Analog Inputs

How come the display flashes HHHH or LLLL when I try to read a signal at input A or input B in linear mode?

There are possibly two reasons; the decimal point setting in the Calc menu has to be adjusted for the maximum signal level to be read or the signal level has exceeded the range of the input channel. Channel A is set up primarily for thermocouple levels from -10mV to 70mV. Channel B is set up for oxygen sensor millivolt ranges of 0 to 2000 mV. The display decimal point setting will not truncate the input value, it just increases the resolution of the input signal. If the value is within the input range of the channel but greater than or less than the possible display setting then the limit warnings will flash on the display.

I am trying to offset the temperature using the offset and scaling number in the Input menu but the temperature does not change.

The input offset and scaling numbers for inputs A and B only work if either Linear A or Linear B are selected as the process source in the Control Menu. If it is necessary to offset the temperature slightly it is possible to do this by changing the cold junction trim adjustment in the Input Calibration menu. It is not recommended that the actual linear calibration values for input A are changed.

Can the temperature and millivolt reading updates respond faster to changes while in calibration mode?

The zero and span values displayed in the calibration mode are affected by the filter settings in the INPUT setup menu. To make these values update faster it is necessary to decrease the filter value for either or both of the temperature and millivolts.

Control Outputs

I have a dual contact control mode selected but my second contact does not work.

When a dual control mode is selected it is necessary to also set the high percent output (HIPO) and low percent output (LOPO). In single time proportioning, the default mode, the HIPO is 100 and the LOPO is 0. When a dual mode is selected it is necessary to change the LOPO to -100. In the case of carbon control it is typically required to control gas and air. The first control contact would be connected to the gas solenoid and the second control contact would be connected to the air solenoid. The gas solenoid would be turned on all the time when the control output goes to 100%. Likewise the air solenoid would be on all the time if the control output was -100%.

When would I change my HIPO or LOPO settings to something other than the 100% or -100%?

These values rarely have to be changed but one case that requires it is when the control actuator is not acting in an expected linear fashion. An example would be an SCR driving a heater. If the SCR is not actually turning on until the control signal is at 20% and stops increasing at 80% then the linear response of the actuator is only between 20% and 80%. If the controller assumes the full output range of 0 to 100% then a large delay in process reaction will drive the reset function in the PID control calculation into oscillation. It would be necessary to set the LOPO to 20% and the HIPO to 100% to achieve stable control.

Digital Communications

How come I have communications problems with an instrument address following a Versapro address setting.

If the timer function has been enabled and the Versapro host protocol is set to 'Prop' for the Marathon protocol, the instrument will take the next host address setting to respond with the timer parameters. The problem can be corrected by turning off the timer function in the Control menu or setting the next instrument address to Versapro host address + 2.

Display Functions

How come the display flashes HHHH or LLLL when I try to read a signal at input A or input B in linear mode?

There are possibly two reasons; the decimal point setting in the Calc menu has to be adjusted for the maximum signal level to be read or the signal level has exceeded the range of the input channel. Channel A is set up primarily for thermocouple levels from -10mV to 70mV. Channel B is set up for oxygen sensor millivolt ranges of 0 to 2000 mV. The display decimal point setting will not truncate the input value. If the value is within the input range of the channel but greater than or less than the possible display setting then the limit warnings will flash on the display.

How come the process values will not cycle on the display when I press the Enter key?

The display will not cycle through the process values if there is an active alarm. Press the Enter key to see any active alarms. If multiple alarms are active it will be

necessary to press the UP or DOWN keys until all of the alarms have been displayed. It is necessary to clear these alarms before the display will cycle by pressing the Enter key.

Probe Care

How can I clear the Probe Fault alarm?

The probe fault can only be cleared with a successful test. Several ways to force this are to start and then quickly stop the probe tests or set the test criteria above the last test data collected during the failure.

I keep getting the Probe Fault alarm but do not know what the problem is?

A probe fault can occur if one of several parameters exceeds defined limits. These parameters are set in the Probe Care menu. For the carbon, oxygen, and dew point processes the probe impedance and probe impedance recovery time are tested when the 'res' or 'both' modes are selected in the probe menu. If the Probe Impedance Limit (Kohm) or Impedance Recovery Time limit (seconds) are exceeded then the probe fault condition is set.

The 'burnoff' or 'both' test modes for carbon and dewpoint are compared to a burnoff test recovery time setting (seconds). If the mV output of the sensor measured prior to the test does not return to previous level within the recovery time setting then the probe fault condition is set.

The 'verify' or 'both' test modes for oxygen measure the oxygen during the introduction of a known test gas. If this measurement does not fall within the limits of the standard verification gas setting and the allowed tolerance then the probe fault will be set. Most of the probe test results are displayed in the display cycle by pressing the Enter key but if a fault has occurred this function is disabled so that multiple alarms may be viewed. It is necessary to go to the Info menu to view the probe test measurements and compare these data to the probe test settings.

How come the probe test will not start?

One of the probe test parameters is minimum test temperature. The default of this temperature is 1400. If the measured temperature is below this value the test will not run. This minimum temperature setting is limited by the minimum temperature required for the sensor to operate. This limit is typically 1000 to 1100 mV. Trying to do a probe test below these temperatures or with no process atmosphere present will not produce any reliable information.

Timer Function

How come I cannot enter a timer setpoint.

Two things have to be set for the timer to work; the timer has to be enabled in the Control Menu, and a timer alarm function has to be selected for alarm 1 or alarm 2 but not both alarms at the same time. Only when these conditions have been met will the instrument accept a timer setpoint.

How come I cannot start a timer function when the Input Event is set to Start and activated?

Make sure all of the conditions explained in the first question of this time section have been met.

Why is there a delay between the Timer display changing to zero and the End alarm coming on?

The timer is counting in milliseconds but only displays whole seconds. When the display first changes from 1 to 0 it actually changes to 0.99. It continues to count down for the remaining milliseconds until the timer reaches zero at which point it turns on the End alarm.

Technical Specification

Environmental ratings

Panel sealing:	Instruments are intended of indoor panel mounting or protected outdoor installation. The rating of panel sealing is IP 51.
Operating temperature:	0 to 55°C. Ensure the enclosure provides adequate ventilation.
Relative humidity:	5 to 95%, non-condensing.
Atmosphere:	The instrument is not suitable for use above 2000m or in explosive or corrosive atmospheres.

Equipment ratings

Supply voltage:	100 to 240Vac -15%, +10%, or optionally:
Supply frequency:	48 to 62Hz.
Power consumption:	15 Watts maximum.
Relay 2-pin (isolated):	Maximum: 264Vac, 2A resistive. Minimum: 12Vdc, 100mA.
Relay changeover (isolated):	Maximum: 264Vac, 2A resistive. Minimum: 6Vdc, 1mA.
Over current protection:	External over current protection devices are required that match the wiring of the installation. A minimum of 0.5mm ² or 16awg wire is recommended. Use independent fuses for the instrument supply and each relay output. Instrument supply: 85 to 264Vac, 2A.
Relay outputs:	Triac outputs: 1A.
Low level I/O:	All analog input and output connections are intended for low level signals less than 24VDC.
DC output (Isolated):	0 to 20mA (650Ω max), 0 to 10V (using a 500Ω dropping resistor).
Fixed digital inputs:	Contact closure. (common to internal 5VDC source.)
DC or PV input:	As main input plus 0-1.6Vdc, Impedance, >100MΩ. (isolated.)
Transmitter supply:	30Vdc at 20mA. (isolated.)
Digital Comms:	EIA-485 half duplex. (isolated).

General

Thermocouple input:	Type B, K, R, and S accuracy after linearization +/- 1 deg F
Millivolt input :	0 to 2000 millivolts +/- 0.1 millivolt
Cold junction compensation:	0 to 60°C +/- 1 deg F
Calibration accuracy:	The greater of ±0.2% of reading, ±1 LSD or ±1°C.
Isolation:	1000V DC/AC Power input to signal inputs Power input to communications
Calculations:	Percent carbon 0 – 2.55% (no CO compensation) Dewpoint -99 – 212 °F (no hydrogen compensation) Percent oxygen. 0 – 20.9% (Small oxygen concentrations can be measured by changing the exponent setting.)
Accuracy:	+/- 1 of LSD of process value.

Probe Care: Probe verification and impedance for oxygen probes.

Communications port: RS-485 Half Duplex Only
 Protocol: 10Pro, MMI block transfer, or Modbus RTU
 Baud rates: 1200, 2400, 4800, 9600, 19.2K
 Parity: Even, odd, or None

Control Mode

Time Proportioning Single Contact Direct
 Time Proportioning Single Contact Reverse
 Time Proportioning Dual Contact Direct
 Time Proportioning Dual Contact Reverse
 Time Proportioning Complement Contact Direct
 Time Proportioning Complement Contact Reverse
 Position Proportioning Direct
 Position Proportioning Reverse
 On / Off Direct
 On / Off Reverse
 On / Off Dual Direct
 On / Off Dual Reverse
 On / Off Complement Direct
 On / Off Complement Reverse

Alarm Type (both Alarm 1 and 2)

High Limit Temp
 Low Limit Temp
 Process Deviation Band
 Process Deviation High
 Process Deviation Low
 Control Percent Out
 Input Fault (mV or Thermocouple)
 Time (start timer no conditions)
 Start (guaranteed timer at set point)
 Soak (guaranteed timer run in band)

Digital Event Input (isolated contact closure)

Probe Burnoff
 Manual/Auto
 Local/Remote
 Alarm Acknowledgement
 Freeze Process
 Start Timer
 Hold Timer
 Acknowledged Timer End

Note: Specifications may change without notification.

Versapro Memory Map

NOTE: Modbus refers to the hexadecimal address location. These parameters are formatted as unsigned 16 bit integers. Any real number such as temperature can be evaluated as a signed number, other parameters are bit mapped words that must be evaluated as single bits are bit groups.

BLOCK 0				
HEX	DEC	PARAMETER	DESCRIPTION	R/W
00	0	IDLE	Idle processor count. This number should never be 0.	READ ONLY
01	1	RSETPT	Remote setpoint sent to the instrument from the Host port. This number has to be scaled to the range of the displayed process value based on the decimal point and exponent settings of the instrument. Range = -999 to 9999 Default = 0.000 For example: If the process = oxygen, display decimal point = 2, and exponent = 6, as remote setpoint of 1234 would be interpreted and displayed as 12.34 ppm.	R/W
02	2	LSETPT	Process setpoint set by the operator through the Setpoint menu. This number is scaled to the range of the displayed process value based on the decimal point and exponent settings of the instrument. Range = -999 to 9999 Default = 0.000	READ ONLY
03	3	TSETPT	Timer setpoint set via the Host port or locally. Range = 0 to 999 minutes Default = 0	R/W
04	4	PROC	This value is the calculated process value shown as an integer. The decimal point and exponent values are required to determine the actual scaled value. Range = -999 to 9999. For example: If the process = oxygen, display decimal point = 2, and exponent = 6, and PROC = 1234, then the actual value and displayed as 12.34 ppm.	READ ONLY
05	5	TIME	This is the remaining time on the timer as it counts down from Time Setpoint. Zero indicates timer has stopped. Range = 0 to 999 minutes Default = 0	READ ONLY
06	6	ALARM1	Alarm value is based on process value display decimal point and exponent. Both are required to determine the real alarm	READ ONLY

BLOCK 0				
HEX	DEC	PARAMETER	DESCRIPTION	R/W
			value. Range = -999 to 9999. Default = 0000	
07	7	ALARM2	Alarm value is based on process value display decimal point and exponent. Both are required to determine the real alarm value. Range = -999 to 9999. Default = 0000	READ ONLY
08	8	ALRMMD1	Alarm 1 configuration BITS 0 – 3 0000 = OFF (DEFAULT) 0001 = DEVIATION BAND 0010 = BAND LOW 0011 = BAND HIGH 0100 = PERCENT OUT LOW 0101 = PERCENT OUT HIGH 0110 = FULL SCALE LOW 0111 = FULL SCALE HIGH 1000 = PROBE IMPEDANCE / VERIFY 1001 = SPARE 1010 = SPARE 1011 = SPARE 1100 = START 1101 = SOAK 1110 = TIMER 1111 = FAULT BIT 4 ACTION CONTROL 0 = DIRECT 1 = REVERSE BIT 5 NO LATCH = 0, LATCHED = 1 BIT 6 – 15 SPARE	READ ONLY
09	9	ALRMMD2	Alarm 2 configuration BITS 0 – 3 0000 = OFF (DEFAULT) 0001 = DEVIATION BAND 0010 = BAND LOW 0011 = BAND HIGH 0100 = PERCENT OUT LOW 0101 = PERCENT OUT HIGH 0110 = FULL SCALE LOW 0111 = FULL SCALE HIGH 1000 = PROBE IMPEDANCE / VERIFY 1001 = SPARE 1010 = SPARE	READ ONLY

BLOCK 0				
HEX	DEC	PARAMETER	DESCRIPTION	R/W
			1011 = SPARE 1100 = START 1101 = SOAK 1110 = TIMER 1111 = FAULT BIT 4 ACTION CONTROL 0 = DIRECT 1 = REVERSE BIT 5 NO LATCH = 0 LATCHED = 1 BIT 6 – 15 SPARE	
0A	10	PB	Proportional Band – Based on display units Range = 1 to 9999 Default = 20	READ ONLY
0B	11	RESET	Reset – Based on seconds Range = OFF to 9999 Where 0020 is assumed to be 00.20 seconds Default = OFF (reset value = 0)	READ ONLY
0C	12	RATE	Rate – Based on seconds Range = OFF to 9999 Where 0020 is assumed to be 00.20 seconds Default = OFF (rate value = 0)	READ ONLY
0D	13	CYCTIM	Cycle Time – Based on seconds Range = 0.2 to 9999 Where 0002 is assumed to be 0002 seconds Default = 30	READ ONLY
0E	14	RSTC	TruCarb Sensor real time resistance not corrected for resistance due to temperature. The value is an integer with an implied milliohm resolution.	READ ONLY
0F	15	HIPO	Control Output High Limit Range = -100 to 100 where HIPO is always greater than LOPO. Default = 100	READ ONLY
10	16	LOPO	Control Output Low Limit Range = -100 to 100 where LOPO is always less than HIPO. Default = 0	READ ONLY
11	17	CONMD	Control Type setting BITS 0 – 3= CONTROL PARAMETER 0000 = SPARE 0001 = Temperature 0010 = Millivolt INPUT B	READ ONLY

BLOCK 0				
HEX	DEC	PARAMETER	DESCRIPTION	R/W
			0011 = Carbon 0100 = Dewpoint 0101 = Oxygen 0110 = Redox 0111 = Millivolt INPUT A 1000 = GC Carbon BIT 4 = NORMAL (0) FREEZE CONTROL OUTPUT (1) BITS 5 – 7 = MODE 000 = TIME PROPORTIONING 001 = TIME PROP W/ COMPLEMENT 010 = TIME PROP, DUAL 011 = SPARE 100 = ON/OFF 101 = ON/OFF W/ COMPLEMENT 110 = ON/OFF, DUAL 111 = VALVE POSITIONING W/ FEEDBACK BIT 8 = DIRECT (0) OR REVERSE (1) ACTING BIT 9 = MANUAL (0) OR AUTO (1) BIT 10 = SETPT LOCAL (0) OR SETPT REMOTE (1) BIT 11 = MONITOR (0), CONTROLLER (1) BITS 12 = SENSOR BREAK OUTPUT 0 (0), OUTPUT HOLD (1) BITS 13 – 15 NOT USED	
12	18	CONFIG0	Input Configuration BITS 0-3 TC Input TYPE 0000 = B (DEFAULT) 0001 = E 0010 = J 0011 = K 0100 = N 0101 = R 0110 = S 0111 = T 1000 = SPARE 1001 = SPARE 1010 = SPARE 1011 = SPARE	READ ONLY

BLOCK 0				
HEX	DEC	PARAMETER	DESCRIPTION	R/W
			1100 = SPARE 1101 = SPARE 1110 = SPARE 1111 = SPARE BIT 4 = SPARE BIT 5 0 = NO CJ APPLIED, 1 = CJ APPLIED BIT 6 0 = °F, 1 = °C BIT 7 0 = 60HZ FILTER BIT 8 – 11 Millivolt Input TYPE 0000 = LINEAR (DEFAULT) All other bit combinations are spare BITS 12 – 15 are spare	
13	19	CTRLOUT	Control Output, unsigned integer Actual control output where: 1000 = 100.0% and 64536 = -100.0%	READ ONLY
14	20	ALRMT1	ALARM 1 ON/OFF TIMES RANGE = 0 – 255 SECONDS DEFAULTS = 0 BIT 0-7 = ON TIME BIT 8-15 = OFF TIME	READ ONLY
15	21	ALRMT2	ALARM 2 ON/OFF TIMES RANGE = 0 – 255 SECONDS DEFAULTS = 0 BIT 0-7 = ON TIME BIT 8-15 = OFF TIME	READ ONLY
16	22	FAULT	FAULT BIT MAP BIT 0 = Temperature Input Open BIT 1 = MV Input Open BIT 2 = Range of input is low BIT 3 = Range of input is high BIT 4 = Timer End BIT 5 = Probe Care Fault BITS 6 – 7 = SPARE BIT 8 = CPU Fault BIT 9 = Min Idle counter = 0 BIT 10 = Keyboard failure, stuck key or a key was pressed during power up. BIT 11 = Flash Erase Failed BIT 12 = Flash Checksum Failed BIT 13 = EEPROM Checksum Failed BIT 14 = Flash/EEPROM Size Fault BIT 15 = ADC Fault	READ ONLY
17	23	CJTRM	COLD JUNCTION TRIM RANGE = -128 TO +127 WHERE 1 COUNT = 1 DEG (C or F) and -128 = 65408	READ ONLY

BLOCK 1				
HEX	DEC	PARAMETER	DESCRIPTION	READ/WRITE
18	24	ASRC	<p>ANALOG OUT SOURCES</p> <p>LOW BYTE, ANALOG OUTPUT 1</p> <p>BITS 0 – 3</p> <p>0000 = N/A</p> <p>0001 = Temperature</p> <p>0010 = Linear Input A</p> <p>0011 = Carbon value</p> <p>0100 = Dewpoint value</p> <p>0101 = Oxygen value</p> <p>0110 = Redox value</p> <p>0111 = Output Power</p> <p>1000 = Control Output 1</p> <p>1001 = Control Output 2</p> <p>1010 = Linear Input B</p> <p>1011 = Programmable*</p> <p>*For Programmable, write required output value into DACV1, where DACV1 = 0 is minimum output and DACV1 = 4096 is maximum output.</p> <p>BITS 4 – 7 SPARE</p> <p>HIGH BYTE, ANALOG OUTPUT 2</p> <p>BITS 8 – 12</p> <p>0000 = N/A</p> <p>0001 = Temperature</p> <p>0010 = Linear Input A</p> <p>0011 = Carbon value</p> <p>0100 = Dewpoint value</p> <p>0101 = Oxygen value</p> <p>0110 = Redox value</p> <p>0111 = Output Power</p> <p>1000 = Control Output 1</p> <p>1001 = Control Output 2</p> <p>1010 = Linear Input B</p> <p>1011 = Programmable*</p> <p>*For Reference Number and Programmable, write required output value into DACV2, where DACV2 = 0 is minimum output and DACV2 = 4096 is maximum output.</p> <p>BITS 13 – 15 SPARE</p> <p>Special case: If Analog Output 1 = CONTROL OUTPUT 1 and Analog Output 2 = CONTROL OUTPUT 2 and the Control</p>	READ ONLY

BLOCK 1				
HEX	DEC	PARAMETER	DESCRIPTION	READ/WRITE
			Mode is dual, then Analog Output 1 is 4-20ma for 0 to +100% PO and Analog Output 2 is 4-20ma for 0 to -100% PO.	
19	25	AOUTOF1	ANALOG OUTPUT 1 OFFSET Minimum source value that correlates to minimum Analog Output of 4 mA. The source value is based on the selection in ASRC lower byte	READ ONLY
1A	26	AOUTRN1	ANALOG OUTPUT 1 RANGE Maximum source value that correlates to maximum Analog Output of 20 mA. The source value is based on the selection in ASRC lower byte where	READ ONLY
1B	27	AOUTOF2	ANALOG OUTPUT 2 OFFSET Minimum source value that correlates to minimum Analog Output of 4 mA. The source value is based on the selection in ASRC upper byte	READ ONLY
1C	28	AOUTRN2	ANALOG OUTPUT 2 RANGE Maximum source value that correlates to maximum Analog Output of 20 mA. The source value is based on the selection in ASRC upper byte where	READ ONLY
1D	29	TEMPFIL	Temperature Input Filter in seconds Range = 0 to 450. The higher the number the slower the reading update. DEFAULT = 10	READ ONLY
1E	30	MVFIL	Millivolt Input Filter in seconds Range = 0 to 450. The higher the number the slower the reading update. DEFAULT = 10	READ ONLY
1F	31	CONFIG2	SETUP VALUES BITS 0 - 4 OXYGEN EXPONENT RANGE = 0 to 31, where 2 = % and 6 = ppm DEFAULT = 2 BITS 5 - 6 DISPLAY DECIMAL PLACE where: 0 = no decimal point in display 1 = Display XXX.X 2 = Display XX.XX 3 = Display X.XXX DEFAULT = 0 BITS 8 - 12 REDOX METAL NUMBER RANGE = 0 - 14 DEFAULT = 0	READ ONLY

BLOCK 1				
HEX	DEC	PARAMETER	DESCRIPTION	READ/WRITE
			BITS 13 – 15 SPARE	
20	32	COLDJCT	COLD JUNCTION Where 1 COUNT = 1°F (°C), RANGE = -99 TO 255°F (°C). Note this parameter is an unsigned integer.	READ ONLY
21	33	TEMP	MEASURED TEMPERATURE Where temperature is presented in degrees C or F, based on the C/F setting. Note this parameter is an unsigned integer of temperature -2721 = 62815 Range = max / min range of selected thermocouple.	READ ONLY
22	34	MV	MEASURED MILLIVOLT Where this value is scaled in 0.1 mV increments, i.e. 10001 = 1000.1. Range = 0 to 2000 mV.	READ ONLY
23	35	HADR AND SIOSET	LOW BYTE – HOST ADDRESS BITS 0-7 RANGE = 0 – 255 HIGH BYTE – SIO SETUP BITS 8 – 9 PARITY SETTING 00 = Even Parity, 7 bits, 1 Stop bit 01 = No Parity, 8 bits, 1 Stop bit 10 = Odd Parity, 7 bits, 1 Stop bit BITS 10 – 11 RESPONSE DELAY 0 = No delay applied to response 1 = 10ms delay applied to response 2 = 20ms delay applied to response 3 = 30ms delay applied to response BITS 12 – 14 BAUD SELECT 000 = 76.8K 001 = 38.4K 010 = 19.2K (DEFAULT) 011 = 9600 100 = 4800 101 = 2400 110 = 1200 111 = 600 BIT 15 HOST FORMAT 0 = MMI (PROP) 1 = MODBUS (DEFAULT)	READ ONLY
24	36	PF	PROCESS FACTOR FOR CARBON OR DEWPOINT RANGE = 0 to 4095 Carbon DEFAULT = 150	READ ONLY

BLOCK 1				
HEX	DEC	PARAMETER	DESCRIPTION	READ/WRITE
			TruCarb DEFAULT = 1.000 ohm This is the RS00 cal value for the TruCarb sensor assuming a 1.000 ohm resistance for 0% carbon at 800°C.	
25	37	DACV1	ANALOG OUTPUT 1 0 to 4095 is 4 to 20 mA In dual mode 4mA = -100, 12mA = 0, 20mA = +100	READ ONLY
26	38	DACV2	ANALOG OUTPUT 2 0 to 4095 is 4 to 20 ma In dual mode 4mA = -100, 12mA = 0, 20mA = +100	READ ONLY
27	39	LOCK AND PLIM	LOW BYTE – LOCK LEVEL BITS 0 – 2 LOCK LEVEL; 0-3 0 is full lock, 3 is wide open BITS 3 – 7 SPARE HIGH BYTE – PROBE IMPEDANCE LIMIT 0 – 255 KOHMS, DEFAULT VALUE = 20K For TruCarb this limit has a default of 1.14 ohms with a limit of 2.55 ohms.	READ ONLY
28	40	PIMP	LAST PROBE IMPEDANCE VALUE For oxygen, carbon, and dew point this is the impedance of an oxygen sensor (KOHMS X 10) i.e. 25 = 2.5 KOHMS For TruCarb this is the RSTC cal. The final (lowest) resistance value of the sensor resistance during a decarb cycle. i.e. 2109 = 2.109 ohms.	READ ONLY
29	41	PRTM	LAST PROBE RECOVERY TIME FROM IMPEDANCE TEST (SECONDS) RANGE = 0 to 255 Available for Redox, Carbon, and Dewpoint. Not available for TruCarb.	READ ONLY
2A	42	PBOMV	LAST MILLIVOLTS DURING PROBE BURN OFF RANGE = -99 TO 2048 i.e. 1018 = 1018 mV Available for Redox, Carbon, Dewpoint, and TruCarb.	READ ONLY
2B	43	PBOTC	LAST TEMPERATURE DURING PROBE BURNOFF RANGE = 0 to 3000 i.e. 1715 = 1715° (F or C based on CONFIG0 BIT 6) Available for Redox, Carbon, Dewpoint, and TruCarb.	READ ONLY
2C	44	PBORT	LAST PROBE BURNOFF RECOVERY TIME RANGE = 0 – 255 SECONDS	READ ONLY

BLOCK 1				
HEX	DEC	PARAMETER	DESCRIPTION	READ/WRITE
			Available for Redox, Carbon, and Dewpoint.	
2D	45	PREMT	REMAINING TIME TO NEXT PROBE TEST RANGE = 0 – 999 Where 999 = 99.9 hours	READ ONLY
2E	46	VGAS	For Oxygen Controller: Measured Verification gas. Value = Actual measured oxygen (0.1%)	READ ONLY
2F	47	PMC	PROBE MAINTENANCE CONTROL WORD BITS 0 – 1 00 = START FULL MAINTENANCE 01 = START BURNOFF (VERIFY) ONLY 10 = START PROBE IMP ONLY 11 = NONE BITS 2 – 6 UNDEFINED BIT 7 = NORMAL (0), CANCEL (1) BITS 8 – 15 = PROBE MAINTENANCE SEQUENCE NUMBER	READ/WRITE

BLOCK 2				
HEX	DEC	PARAMETER	DESCRIPTION	R/W
30	48	PTINT	PROBE TEST INTERVAL SETTING (HRS) Operator input for interval setting RANGE = 0 – 999 Where 999 = 99.9 hours DEFAULT = 0 (Disable Probe test)	READ ONLY
31	49	PTRECT	PROBE TEST RECOVERY TIME SETTING (SECONDS) RANGE = 0 to 999 DEFAULT = 30	READ ONLY
32	50	BOTM	BURN OFF TIME SETTING (SECONDS) RANGE = 0 to 999 DEFAULT = 30 Burnoff function available for Redox, Carbon, and Dewpoint.	READ ONLY
33	51	BOREC	BURN OFF RECOVERY TIME SETTING (SECONDS) RANGE = 0 to 999 DEFAULT = 30 Burnoff function available for Redox, Carbon, and Dewpoint.	READ ONLY
34	52	VSTD	VERIFY TEST GAS STANDARD For oxygen process this is the test standard value used to verify the probe.	READ ONLY

BLOCK 2				
HEX	DEC	PARAMETER	DESCRIPTION	R/W
			RANGE = 0 to 999 Where the value 999 = 99.9% oxygen DEFAULT = 30 (3.0%) For TruCarb this is the FTCS calibration value. This is the temperature correction factor in milliohms to compensate the wire resistance during decarb for the temperature measured during the decarb process.	
35	53	VTOL	VERIFY TEST TOLERANCE SETTING This setting establishes the limit as VSTD \pm VTOL when comparing to the measured value VGAS Range = 0 to 999 Where 0005 = 00.5% DEFAULT = 0005 Verify function available for Oxygen.	READ ONLY
36	54	TAVE	VERIFICATION SAMPLE AVERAGING SETTING (SECONDS) RANGE = 0 to 999 DEFAULT = 2 Verify function available for Oxygen.	READ ONLY
37	55	TDEL1	VERIFY DELAY 1 SETTING (SECONDS) RANGE = 0 to 999 DEFAULT = 30 Verify function available for Oxygen.	READ ONLY
38	56	TDEL2	VERIFY DELAY 2 SETTING (SECONDS) RANGE = 0 to 999 DEFAULT = 30 Verify function available for Oxygen.	READ ONLY
39	57	TMIN	MINIMUM TEMPERATURE FOR PROBE CARE TEST This setting establishes the lowest process temperature allowed for a probe test or TruCarb decarburization process to proceed. RANGE = 500°F to 2000°F (260°C to 1090°C) DEFAULT = 1400°F (760°C) NOTE: This value must be checked in the SETUP menu when the temperature scales have been changed.	READ ONLY
3A	58	TC_ZERO	TC ZERO CALIBRATION NUMBER	R/W
3B	59	TC_SPAN	TC SPAN CALIBRATION NUMBER	R/W
3C	60	MV_ZERO	MV ZERO CALIBRATION NUMBER	R/W
3D	61	MV_SPAN	MV SPAN CALIBRATION NUMBER	R/W
3E	62	DAC_OFFSET_1	DAC 1 OFFSET CALIBRATION	READ ONLY
3F	63	DAC_SPAN_1	DAC 1 SPAN CALIBRATION	READ

BLOCK 2				
HEX	DEC	PARAMETER	DESCRIPTION	R/W
				ONLY
40	64	DAC_OFFSET_2	DAC2 OFFSET CALIBRATION	READ ONLY
41	65	DAC_SPAN_2	DAC2 SPAN CALIBRATION	READ ONLY
42	66	AZERO	LINEAR OFFSET, Y INTERCEPT LINEAR SCALING FOR INPUT A	READ ONLY
43	67	ANUM	LINEAR SPAN VALUE FOR INPUT A	READ ONLY
44	68	BZERO	LINEAR OFFSET, Y INTERCEPT LINEAR SCALING FOR INPUT B	READ ONLY
45	69	BNUM	LINEAR SPAN VALUE FOR INPUT B	READ ONLY
46	70	TIME CONTROL AND EVNT	<p>LOW BYTE – INPUT EVENT CONFIGURATION</p> <p>Bits 0 – 3</p> <p>0000 = None</p> <p>0001 = Auto Mode Selected</p> <p>0010 = Remote Setpoint Selected</p> <p>0011 = Acknowledge alarms</p> <p>0100 = Timer Hold</p> <p>0101 = Timer End</p> <p>0110 = Timer Start</p> <p>0111 = Start probe test</p> <p>1000 = Process hold</p> <p>Bits 4 – 7 not used.</p> <p>HIGH BYTE - TIMER CONTROL</p> <p>BIT 0 – SPARE</p> <p>BIT 1 – Timer stop(0), Timer start(1)</p> <p>BIT 2 – Timer running(1)</p> <p>BIT 3 – Timer End Active(1)</p> <p>BIT 4 – Timer Hold Active(1)</p> <p>BIT 5 – 6 SPARE</p> <p>BIT 7 = Timer Disabled (0), Timer Enabled (1)</p>	READ ONLY
47	71	COMP	<p>CO / H COMPENSATION for carbon or dewpoint</p> <p>RANGE 0 – 255</p> <p>DEFAULT = 20 (% CO FOR CARBON)</p> <p>DEFAULT = 40 (% H2 FOR DEWPOINT)</p> <p>For TruCarb this value is the shim stock offset in % carbon, i.e. 0145 = 1.45%</p>	R/W

BLOCK 3				
HEX	DEC	PARAMETER	DESCRIPTION	R/W

BLOCK 3				
HEX	DEC	PARAMETER	DESCRIPTION	R/W
48	72	PSTART	START PROBE TEST Write 1 to start any probe test that has been configured.	R/W
49	73	SPARE		
5A	74	SPARE		
5B	75	SPARE		
5C	76	SPARE		
5D	77	SPARE		
5E	78	SPARE		
5F	79	SPARE		
60	80	SPARE		
61	81	SPARE		
62	82	SPARE		
63	83	SPARE		
64	84	SPARE		
65	85	SPARE		
66	86	SPARE		
67	87	SPARE		
68	88	SPARE		
69	89	SPARE		
6A	8A	SPARE		
6B	8B	SPARE		
6C	8C	SPARE		
6D	8D	SPARE		
6F	8E	SPARE		
70	8F	SPARE		
71	90	SPARE		
72	91	SPARE		
73	92	SPARE		
74	93	SPARE		
75	94	SPARE		
76	95	SPARE		

Versapro Setup Sheet

Control Menu (Ctrl)

Parameter Name	Setting
PROCESS SOURCE	
CONTROL MODE	
CONTROL ACTION	
PROPORTIONAL BAND	
RESET	
RATE	
CYCLE TIME	
HI PERCENT OUT	
LOW PERCENT OUT	
TIMER ENABLE	
TC OR MV BREAK	

Input Menu (InPt)

Parameter Name	Settings
TC TYPE	
COLD JUNC APPLY	
IN A OFFSET	
IN A SLOPE	
TEMP SCALE	
TC FILTER	
IN B OFFSET	
IN B SLOPE	
MV FILTER	
DIG EVENT	

Calculation Menu (CALC)

Parameter Name	Settings
DISPLAY DECML PT	
PROCESS FACTOR	
CO COMPENSATION	
DEWPT DEGREES	

Probe Setup Menu (PrOb)

Parameter Name	Settings
PROBE TEST	
TEST INTERVAL	
PROBE IMP LIMIT	
IMP RECVRY TIME	
BURNOFF TIME	
BURNOFF RECOVERY	
MIN PROBE TEMP	

Analog Output Menu (AOUt)

Parameter Name	Settings
ANALOG 1 UNIT	
ANALOG 1 OFFSET	
ANALOG 1 RANGE	
ANALOG 2 UNIT	
ANALOG 2 OFFSET	
ANALOG 2 RANGE	

Alarm Menu (ALr)

Parameter Name	Settings
ALARM 1 TYPE	
ALARM 1 VALUE	
ALARM 1 ACTION	
ALRM 1 TM ON DLY	
ALRM 1 TMOFF DLY	
ALARM 2 TYPE	
ALARM 2 VALUE	
ALARM 2 ACTION	
ALRM 2 TM ON DLY	
ALRM 2 TMOFF DLY	

Communication Menu (HOST)

Parameter Name	Settings
PROTOCOL	
ADDRESS	
BAUD RATE	
PARITY	
DELAY	



Reach us at www.group-upc.com

United Process Controls brings together leading brands to the heat treating industry including Waukee Engineering, Furnace Control, Marathon Monitors and Process-Electronic.

We provide prime control solutions through our worldwide sales and services network with easy-to-access local support.



UNITED PROCESS CONTROLS INC.
8904 Beckett Road, West Chester, OH 45069, USA

Phone: +1-513-772-1000 Fax: +1-513-326-7090
Toll-Free North America +1-800-547-1055
E-mail: upc.sales@group-upc.com

