



AACC 2200 (Oxygen) Monitor / Controller Installation and Operation Handbook

COPYRIGHT © 1998
MARATHON MONITORS INC.



AFFILIATED MEMBERS

Furnace Control Corp.

Marathon Monitors Inc.

Process-Electronic

Waukee Engineering Co.

Marathon Monitors Inc.

Part # F200049

COPYRIGHT © 1998
MARATHON MONITORS INC.

No part of this document may be stored or reproduced by any means whatsoever without prior written permission of Marathon Monitors Inc.

All trademarks used in this publication are duly marked and the sole property of their respective owners. No attempt at trademark or copyright infringement is intended or implied.

Marathon Monitors makes no warranties express or implied beyond the written warranty presented at initial purchase. Marathon Monitors Inc. is not responsible for any product, process, damage or injury incurred while using this equipment. Marathon Monitors makes no representations or warranties with respect to the contents hereof and specifically disclaims any warranties of merchantability or fitness for any particular application or purpose.

REVISION 1.1.1 – 1998-02-26 – add typical wiring diagram

REVISION 1.1.2 – 1998-04-26 – Fix missing Bit maps.

REVISION 1.1.3 – 1998-11-10 – General Corrections.

For assistance please contact:

Marathon Monitors Inc.

TEL: +1 513 772 1000 • FAX: +1 513 326 7090

Toll-Free North America +1-800-547-1055

erika.leeds@group-upc.com

AACC 2200 (Oxygen) Series Monitor / Controller

INSTALLATION AND OPERATION HANDBOOK

Aacc2200 Oxygen Monitor/Controller.....4
Safety And Emc Information.....6
Installation Safety Requirements.....7
 Installation Requirements For Emc.....9
Technical Specification10
Installation.....12
 Introduction.....14
 Mechanical Installation.....14
 Wiring Of 2-Wire Eia-485 Serial Communications Link.....22
Operation.....24
 Front Panel Layouts25
 Basic Operation.....27
 Automatic Mode29
 Manual Mode30
 Parameters And How To Access Them.....31
 Parameter Names33
 Parameter Tables.....42
 Probe Verification And Impedance Test.....49
 Probe Verification.....49
 Probe Impedance Test.....50
 Alarms.....52
 Diagnostic Alarms.....53
Access Levels.....54
 Edit Level.....57
 Setting Operator Access To A Parameter.....57
Tuning.....59
 Automatic Tuning60
 Manual Tuning.....62
 Setting The Cutback Values.....63
 Motorized Valve Control65
 Gain Scheduling.....68
Configuration.....69
 Selecting Configuration Level70
 Changing The Passwords71
User Calibration92
 User Calibration Enable93
 Offset Calibration.....94
 Two-Point Calibration.....96
 Calibration Points And Calibration Offsets.....99

“This product is covered by one or more of the following US Patents:

5,484,206; Additional patents pending.

AACC2200 Oxygen Monitor/Controller

Application and General Information

The AACC2200 uses the signals from a zirconia oxygen probe to calculate the oxygen concentration. The oxygen concentration can be displayed in percent, parts per million, or parts per billion by appropriate configuration settings. The calculations are based on the assumption that the reference air supply to the probe is 20.95% O₂.

The differences between the monitor and the controller versions are based on the target applications. The controller is designed to control the concentration of oxygen and therefore displays the oxygen concentration measured on the top display and the target setpoint on the bottom display. The controller also has control algorithms (PID, ON-OFF, etc.) for generating the outputs to adjust the process inputs. The monitor is designed for data acquisition applications and therefore displays the oxygen concentration measured on the top display and the probe temperature on the lower display. The monitor can not generate the outputs needed for controlling the process inputs. The monitor could perform simple ON-OFF control using a full scale high alarm and contact. There is no way to convert a controller to a monitor or a monitor to a controller in the field. The AACC2200 must be returned to the factory for conversion.

The units in which the oxygen concentration is displayed is determined by the EXP parameter under the PV (process variable) configuration list. The resolution of the display is determined by the DP parameter on the same list. The EXP parameter is a power of ten factor. To display in percent set the EXP to 2 (factor is 100). To display in parts per million (ppm) set the EXP to 6 and for parts per billion set EXP to 9. The DP parameter determines the resolution of the displayed value. It can be set as no decimal place (XXXX), one decimal place (XXX.X), or two decimal places (XX.XX).

The input/output structure of the AACC2200 is very flexible. The basic unit with no options contains a form C relay (AA), a thermocouple input (V+/-), a probe care resistor module in position J, a dual relay in position 4, a probe care dual relay in position 5, and a probe millivolt input in position 6. Option modules can be installed in positions 1, 2, 3, and H and are indicated by the last four characters of the part number (-XXXX) respectively. Positions 1 and 2 can support either a dual relay (D) or an analog output (A). Only modules in positions 1 and 2 can be used by the controller as control outputs. Position 3 can support a dual relay (D), a DC output (A), or a DC input module (I). Position H is for communications only with a RS-485 module (C). If no module is installed in a post then it is indicated by an X. the most common configuration for an AACC2200 is for two analog output module is positions 2 and 3 (-XAAX). The standards factory configuration for the two

Marathon Monitors Inc.

analog outputs is different for the monitor and the controller. Both outputs are setup for 4 to 20 milliamp outputs. The monitor has output 2 setup for process variable retransmission for 0 to 25% O₂ and output 3 setup for temperature retransmission for 0 to 3000 degrees. The controller has output 2 setup for control output 0 to 100% and output 3 setup for process variable retransmission for 0 to 25% O₂. These values can be changed in the configuration mode of the instrument.

SAFETY and EMC INFORMATION

Please read this section carefully before installing the controller

This controller is intended for industrial temperature and process control applications where it will meet the requirements of the European Directives on Safety and EMC. Use in other applications, or failure to observe the installation instructions of this handbook may impair the safety or EMC protection provided by the controller. It is the responsibility of the installer to ensure the safety and EMC of any particular installation.

Safety

This controller complies with the European Low Voltage Directive 73/23/EEC, amended by 93/68/EEC, by the application of the safety standard EN 61010.

Electromagnetic compatibility

This controller conforms with the essential protection requirements of the EMC Directive 89/336/EEC, amended by 93/68/EEC, by the application of a Technical Construction File. This instrument satisfies the general requirements of an industrial environment as described by EN 50081-2 and EN 50082-2. For more information on product compliance refer to the Technical Construction File.

SERVICE AND REPAIR

This controller has no user serviceable parts. Contact your nearest MSI Service center (800-322-4444) for repair.

Caution: Charged capacitors

Before removing an instrument from its case, disconnect the supply and wait at least two minutes to allow capacitors to discharge. Failure to observe this precaution will expose capacitors that may be charged with hazardous voltages. In any case, avoid touching the exposed electronics of an instrument when withdrawing it from the case.

Electrostatic discharge precautions

When the controller is removed from its case, some of the exposed electronic components are vulnerable to damage by electrostatic discharge from someone handling the controller. To avoid this, before handling the unplugged controller discharge yourself to ground.

Cleaning

Do not use water or water based products to clean labels or they will become illegible. Isopropyl alcohol may be used to clean labels. A mild soap solution may be used to clean other exterior surfaces of the product.

Installation Safety Requirements

Safety Symbols

Various symbols are used on the instrument, they have the following meaning:



Caution, (refer to the accompanying documents)



Functional earth (ground) terminal

The functional earth connection is not required for safety purposes but to ground RFI filters.

Personnel

Installation must only be carried out by qualified personnel.

Enclosure of live parts

To prevent hands or metal tools touching parts that may be electrically live, the controller must be installed in an enclosure.

Caution: Live sensors

The fixed digital inputs, non-isolated dc, logic and outputs and the logic output of dual output modules, are all electrically connected to the main process variable input. If the temperature sensor is connected directly to an electrical heating element then these non-isolated inputs and outputs will also be live. The controller is designed to operate under these conditions. However you must ensure that this will not damage other equipment connected to these inputs and outputs and that service personnel do not touch connections to these i/o while they are live. With a live sensor, all cables, connectors and switches for connecting the sensor and non-isolated inputs and outputs must be mains rated.

Wiring

It is important to connect the controller in accordance with the wiring data given in this handbook. Take particular care not to connect AC supplies to the low voltage sensor input or other low level inputs and outputs. Only use copper conductors for connections (except thermocouple inputs) and ensure that the wiring of installations comply with all local wiring regulations. For example in the in the UK use the latest version of the IEE wiring regulations, (BS7671). In the USA use NEC Class 1 wiring methods.

Power Isolation

The installation must include a power isolating switch or circuit breaker. This device should be in close proximity to the controller, within easy reach of the operator and marked as the disconnecting device for the instrument.

Earth leakage current

Due to RFI Filtering there is an earth leakage current of less than 0.5mA. This may affect the design of an installation of multiple controllers protected by Residual Current Device, (RCD) or Ground Fault Detector, (GFD) type circuit breakers.

Overcurrent protection

To protect the internal PCB tracking within the controller against excess currents, the AC power supply to the controller and power outputs must be wired through the fuse or circuit breaker specified in the technical specification.

Voltage rating

The maximum continuous voltage applied between any of the following terminals must not exceed 264Vac:

- line or neutral to any other connection;
- relay or triac output to logic, dc or sensor connections;
- any connection to ground.

The controller should not be wired to a three phase supply with an unearthed star connection. Under fault conditions such a supply could rise above 264Vac with respect to ground and the product would not be safe.

Voltage transients across the power supply connections, and between the power supply and ground, must not exceed 2.5kV. Where occasional voltage transients over 2.5kV are expected or measured, the power installation to both the instrument supply and load circuits should include a transient limiting device.

These units will typically include gas discharge tubes and metal oxide varistors that limit and control voltage transients on the supply line due to lightning strikes or inductive load switching. Devices are available in a range of energy ratings and should be selected to suit conditions at the installation.

Conductive pollution

Electrically conductive pollution must be excluded from the cabinet in which the controller is mounted. For example, carbon dust is a form of electrically conductive pollution. To secure a suitable atmosphere in conditions of conductive pollution, install an air filter to the air intake of the cabinet. Where condensation is likely, for example at low temperatures, include a thermostatically controlled heater in the cabinet.

Over-temperature protection

When designing any control system it is essential to consider what will happen if any part of the system should fail. In temperature control applications the primary danger is that the heating will remain constantly on. Apart from spoiling the product, this could damage any process machinery being controlled, or even cause a fire.

Reasons why the heating might remain constantly on include:

- the temperature sensor becoming detached from the process;
- thermocouple wiring becoming a short circuit;
- the controller failing with its heating output constantly on;
- an external valve or contactor sticking in the heating condition;
- the controller setpoint set too high.

Where damage or injury is possible, we recommend fitting a separate over-temperature protection unit, with an independent temperature sensor, which will isolate the heating circuit.

Marathon Monitors Inc.

Please note that the alarm relays within the controller will not give protection under all failure conditions.

Grounding of the temperature sensor shield

In some installations it is common practice to replace the temperature sensor while the controller is still powered up. Under these conditions, as additional protection against electric shock, we recommend that the shield of the temperature sensor is grounded. Do not rely on grounding through the framework of the machine.

Installation requirements for EMC

To ensure compliance with the European EMC directive certain installation precautions are necessary as follows:

- For general guidance refer to MSI Controls EMC Installation Guide, HA025464.
- When using relay or triac outputs it may be necessary to fit a filter suitable for suppressing the emissions. The filter requirements will depend on the type of load. For typical applications we recommend Schaffner FN321 or FN612.
- If the unit is used in table top equipment which is plugged into a standard power socket, then it is likely that compliance to the commercial and light industrial emissions standard is required. In this case to meet the conducted emissions requirement, a suitable mains filter should be installed. We recommend Schaffner types FN321 and FN612.

Routing of wires

To minimize the pick-up of electrical noise, the wiring for low voltage dc and particularly the sensor input should be routed away from high-current power cables. Where it is impractical to do this, use shielded cables with the shield grounded at both ends. See example below.

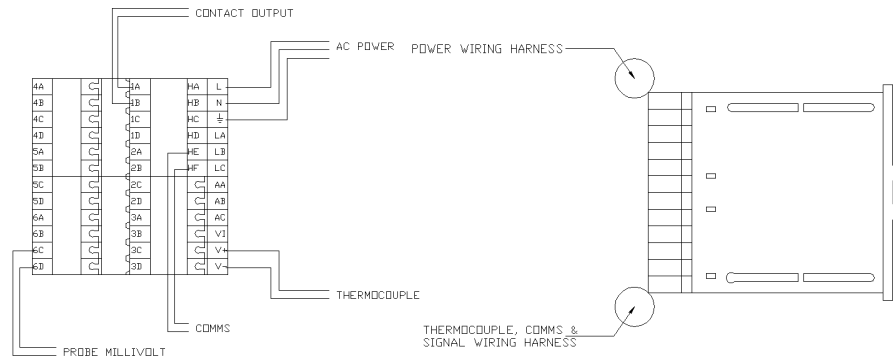

Technical Specification

Environmental ratings

Panel sealing:	Instruments are intended to be panel mounted. The rating of panel sealing is IP65, (EN 60529), or 4X, (NEMA 250).
Operating temperature:	0 to 55°C (32 to 131 °F). Ensure the enclosure provides adequate ventilation.
Relative humidity:	5 to 95%, non condensing.
Atmosphere:	The instrument is not suitable for use above 2000m or in explosive or corrosive atmospheres.

Equipment ratings

Supply voltage:	100 to 240Vac -15%, +10%, or optionally:
Supply frequency:	48 to 62Hz.
Power consumption:	15 Watts maximum.
Relay 2-pin (isolated):	Maximum: 264Vac, 2A resistive. Minimum: 12Vdc, 100mA.
Relay changeover (isolated):	Maximum: 264Vac, 2A resistive. Minimum: 6Vdc, 1mA.
Triac outputs (isolated):	30 to 264Vac. Maximum current: 1A resistive.
Leakage current:	The leakage current through triac and relay contact suppression components is less than 2mA at 264Vac, 50Hz.
Over current protection:	External over current protection devices are required that match the wiring of the installation. A minimum of 0.5mm ² or 16awg wire is recommended. Use independent fuses for the instrument supply and each relay or triac output. Suitable fuses are T type, (EN 60127 time-lag type) as follows; Instrument supply: 85 to 264Vac, 2A, (T). Relay outputs: 2A (T). Triac outputs: 1A (T).
Low level i/o:	All input and output connections other than triac and relay are intended for low level signals less than 42V.
Single logic output:	18V at 24mA. (Non-isolated.)
DC output (Isolated):	0 to 20mA (600Ω max), 0 to 10V (500Ω min).
DC output (Non isolated):	0 to 20mA (600Ω max), 0 to 10V (500Ω min).
Fixed digital inputs:	Contact closure. (Non isolated.)
Triple contact input:	Contact closure. (Isolated.)
Triple logic input:	11 to 30Vdc. (Isolated.)
DC or 2 nd PV input:	As main input plus 0-1.6Vdc, Impedance, >100MΩ. (Isolated.)
Potentiometer input:	0.5V excitation, 100Ω to 1.5kΩ Potentiometer. (Isolated.)
Transmitter supply:	24Vdc at 20mA. (isolated.)
Strain gauge supply:	10Vdc. Minimum bridge resistance 300Ω. (Isolated.)
Digital Communications:	EIA-232, 2-wire EIA-485 or 4-wire EIA-485 (All isolated).

Marathon Monitors Inc.

General

Main PV Input range: $\pm 100\text{mV}$, 0 to 10Vdc (auto ranging) and 3 wire Pt100.
Calibration accuracy: The greater of $\pm 0.2\%$ of reading, ± 1 LSD or $\pm 1^\circ\text{C}$.
Cold junction compensation >30:1 rejection of ambient temperature, (for thermocouple i/p).

Electrical safety

Standards: EN 61010, Installation category II, pollution degree 2.
CSA C22.2 No.142-M1987.

Installation category II: Voltage transients on any main power connected to the instrument must not exceed 2.5kV.

Pollution degree 2: Conductive pollution must be excluded from the cabinet in which the instrument is mounted.

Isolation: All isolated inputs and outputs have reinforced insulation to provide protection against electric shock. The fixed digital inputs, non-isolated dc, logic, and the logic output of dual output modules, are all electrically connected to the main process variable input, (thermocouple etc.).

Installation

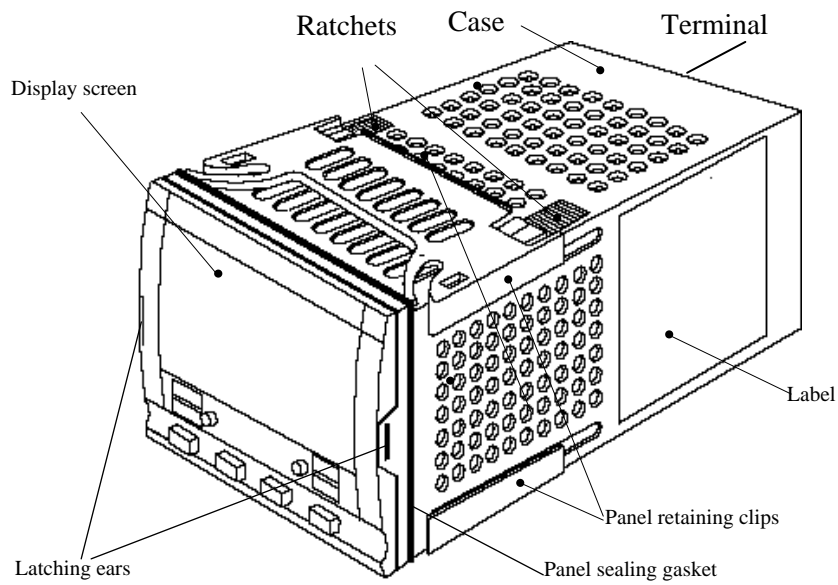

AACC 2200 1/4 DIN controller
Figure 1

Outline dimensions Model 2200

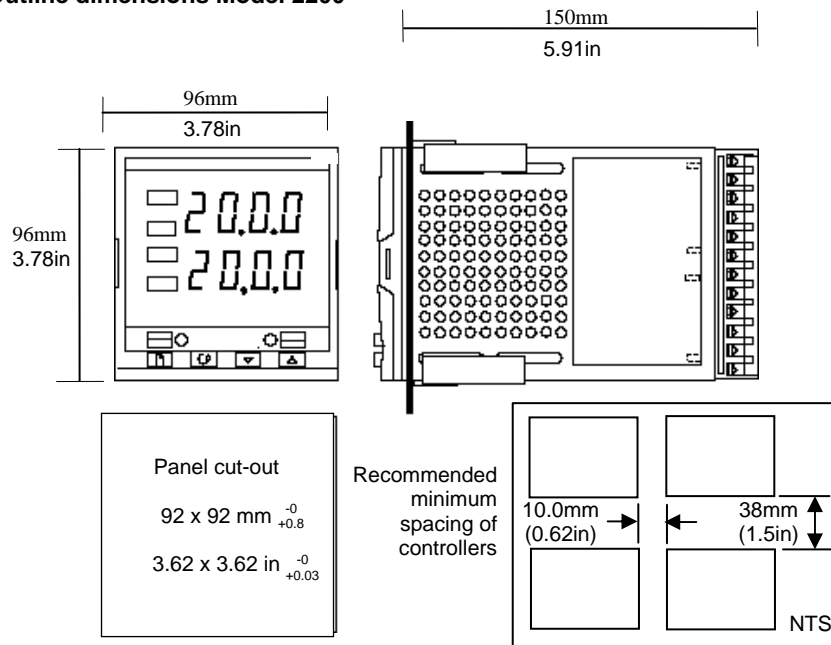

Figure 1-4 Outline dimensions Model 2200 controller

The electronic assembly of the controller plugs into a rigid plastic case, which in turn fits into the standard DIN size panel cut-out shown in Figures 1-3 and 1-4.

Introduction

Model AACC 2200's are high stability, process controllers with self and adaptive tuning. They have a modular hardware construction which accepts up to three plug-in Input/Output modules and two interface modules to satisfy a wide range of control requirements. Two digital inputs and an optional alarm relay are included as part of the standard hardware.

Before proceeding, please read the *Safety and EMC Information*.

Controller labels

The labels on the sides of the controller identify the ordering code, the serial number, and the wiring connections.

Appendix A, *Understanding the Ordering Code*, explains the hardware and software configuration of your particular controller.

MECHANICAL INSTALLATION

To install the controller

1. Prepare the control panel cut-out to the size shown in Figure 2.
2. Insert the controller through the panel cut-out.
3. Spring the upper and lower panel retaining clips into place. Secure the controller in position by holding it level and pushing both retaining clips forward.

Note: If the panel retaining clips subsequently need removing, in order to extract the controller from the control panel, they can be unhooked from the side with either your fingers, or a screwdriver.

Unplugging and plugging-in the controller

If required, the controller can be unplugged from its case by easing the latching ears outwards and pulling it forward out of the case. When plugging the controller back into its case, ensure that the latching ears click into place in order to secure the IP65 sealing.

Marathon Monitors Inc.

All electrical connections are made to the screw terminals at the rear of the controller. If you wish to use crimp connectors, the correct size is AMP part number 349262-1. They accept wire sizes from 0.5 to 1.5 mm² (16 to 22 AWG). A set of connectors is supplied with the controller. The terminals are protected by a clear plastic hinged cover to minimize the possibility of accidental contact with live wires.

Rear terminal layouts

The rear terminal layouts are shown in Figure 3. The right-hand column carries the connections to the power supply, digital inputs 1 and 2, alarm relay and sensor input. The second and third columns from the right carry the connections to the plug-in modules. The connections depend upon the type of module installed, if any. To determine which plug-in modules are fitted, refer to the ordering code and wiring data on the controller side labels.

Model AACC 2200 rear terminal layout

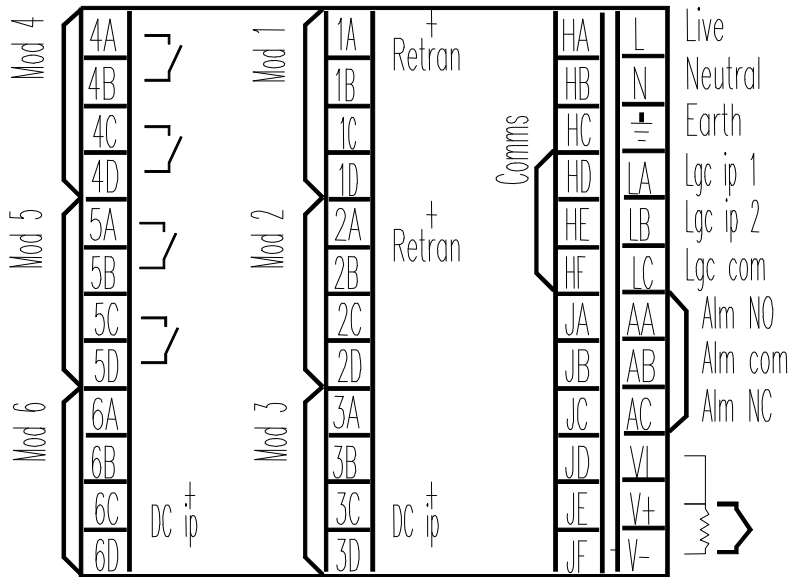

48-62Hz a.c. ~ 85 - 264V 20W

Figure 3 Rear terminal layout

Marathon Monitors Inc.

The display below shows a typical wiring diagram for the AACC2200 Controller:

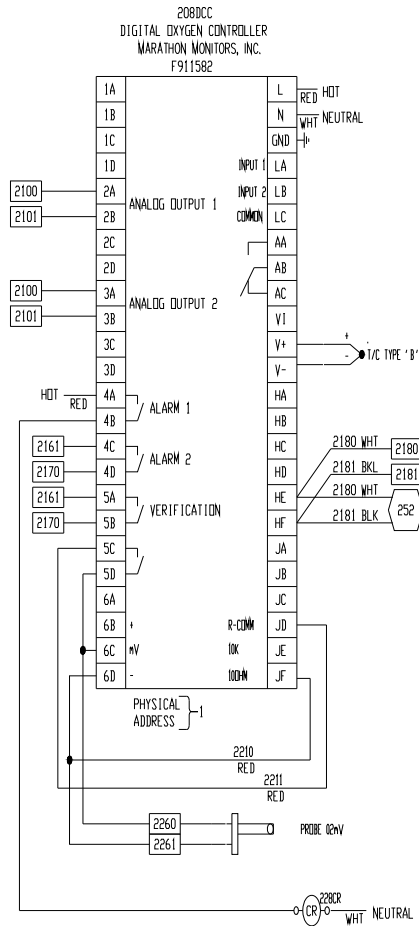

Typically a series of letters appears after the part number, see Legend below.

- D – Dual Relay
 - A – Analog Output
 - X – Not Installed
 - C – Communications
 - I – Analog Input (typically in position 3)
- Sensor input connections

The connections for the various types of sensor input are shown below.

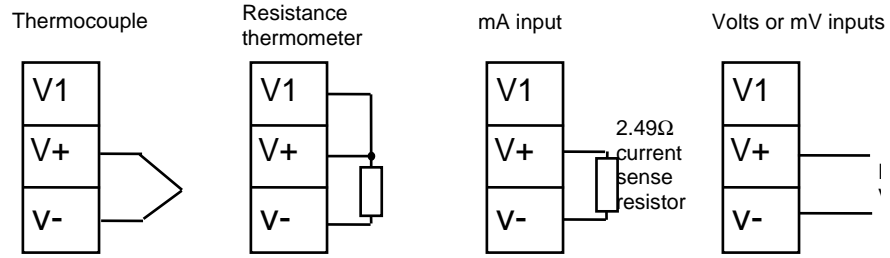

Fig 4 Sensor input connections

PLUG-IN MODULE CONNECTIONS

Module 1, 2 and 3

Module positions 1, 2 and 3 are plug-in modules. They can be either two terminal modules of the types shown in Table 1-8, or four terminal modules of the types shown in Table 1-2. The tables show the connections to each module and the functions that they can perform.

Marathon Monitors Inc.

Two terminal modules

Note: Module 1 is connected to terminals 1A and 1B
 Module 2 is connected to terminals 2A and 2B
 Module 3 is connected to terminals 3A and 3B.



Module type	Terminal identity				Possible functions
	A	B	C	D	
Relay: 2-pin (2A, 264 Vac max.)			Unused		Heating, cooling, alarm, program event, valve raise, or valve lower
Logic - non-isolated (18Vdc at 20mA)			Unused		Heating, cooling, mode 1, mode 2, program event
Triac (1A, 30 to 264Vac)			Unused		Heating, cooling, program event, valve raise, or valve lower
DC output: - non-isolated (10Vdc, 20mA max.)			Unused		Heating, or cooling, or retransmission of PV, setpoint, or control output

Table 1-1 Two terminal module connections

Snubbers

The relay and triac modules have an internal 15nF/100Ω 'snubber' connected across their output, which is used to prolong contact life and to suppress interference when switching inductive loads, such as mechanical contactors and solenoid valves.

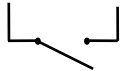
WARNING

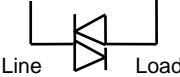
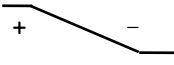
When the relay contact is open, or the triac is off, the snubber circuit passes 0.6mA at 110Vac and 1.2mA at 240Vac. You must ensure that this current, passing through the snubber, will not hold on low power electrical loads. It is your responsibility as the installer to ensure that this does not happen. If the snubber circuit is not required, it can be removed from the relay module (BUT NOT THE TRIAC) by breaking the PCB track that runs crosswise, adjacent to the edge connectors of the module. This can be done by inserting the blade of a small screwdriver into one of the two slots that bound it, and twisting.

Marathon Monitors Inc.

Four terminal modules

Note: Module 1 is connected to terminals 1A, 1B, 1C and 1D
 Module 2 is connected to terminals 2A, 2B, 2C and 2D
 Module 3 is connected to terminals 3A, 3B, 3C and 3D

Module type	Terminal identity				Possible functions
	A	B	C	D	
lay: changeover (2A, 264 Vac max.)					Heating, cooling, or alarm,
DC control: Isolated (10V, 20mA max.)	+	-			Heating, or cooling
24Vdc transmitter supply	+	-			To power process inputs
Potentiometer input 100Ω to 15KΩ		+0.5Vdc		0V	Motorised Valve Position feedback
DC retransmission	+	-			Retrans. of setpoint, or process value
DC remote input or Process Value 2 (Module 3 only)	0-10Vdc	RT source	±100mV 0-20mA	COM	Remote Setpoint Second PV
(Refer to Fig. 1-8)					
Dual output modules					
Dual relay (2A, 264 Vac max.)					Heating + cooling Dual alarms Valve raise & lower
Dual Triac (1A, 30 to 264Vac)					Heating + cooling Valve raise & lower
Dual logic + relay (Logic is non-isolated)					Heating + cooling
Dual Logic + triac (Logic is non-isolated)					Heating + cooling
Triple logic input and output modules - see ratings on the next page					
Triple contact input	Input 1	Input 2	Input 3	Common	
Triple logic input	Input 1	Input 2	Input 3	Common	

Table 1-2 four terminal module connection.

Connections for Process Value 3 in module position 3

The diagrams above show the connections for the various types of input.

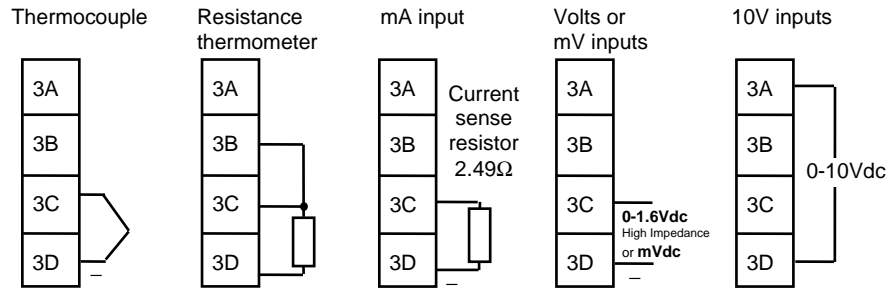

Figure 1-8 Connections for Process Value 2 (PV2)

The input will have been configured in accordance with the ordering code.

Marathon Monitors Inc.

Communication module 1

The Models AACC 2200 will accept a plug-in communications modules.

The possible module types are shown in the table below.

The serial communications can be configured for either Modbus, or MSI protocol.

Communications module 1	Terminal identity (COMMS 1)					
	HA	HB	HC	HD	HE	HF
Module type						
2-wire EIA-485 serial communications	-	-	-	Common	A (-)	B (+)
EIA-232 serial communications	-	-	-	Common	Rx	Tx

Table 1-3 Communication module 1 connections

Wiring of 2-wire EIA-485 serial communications link

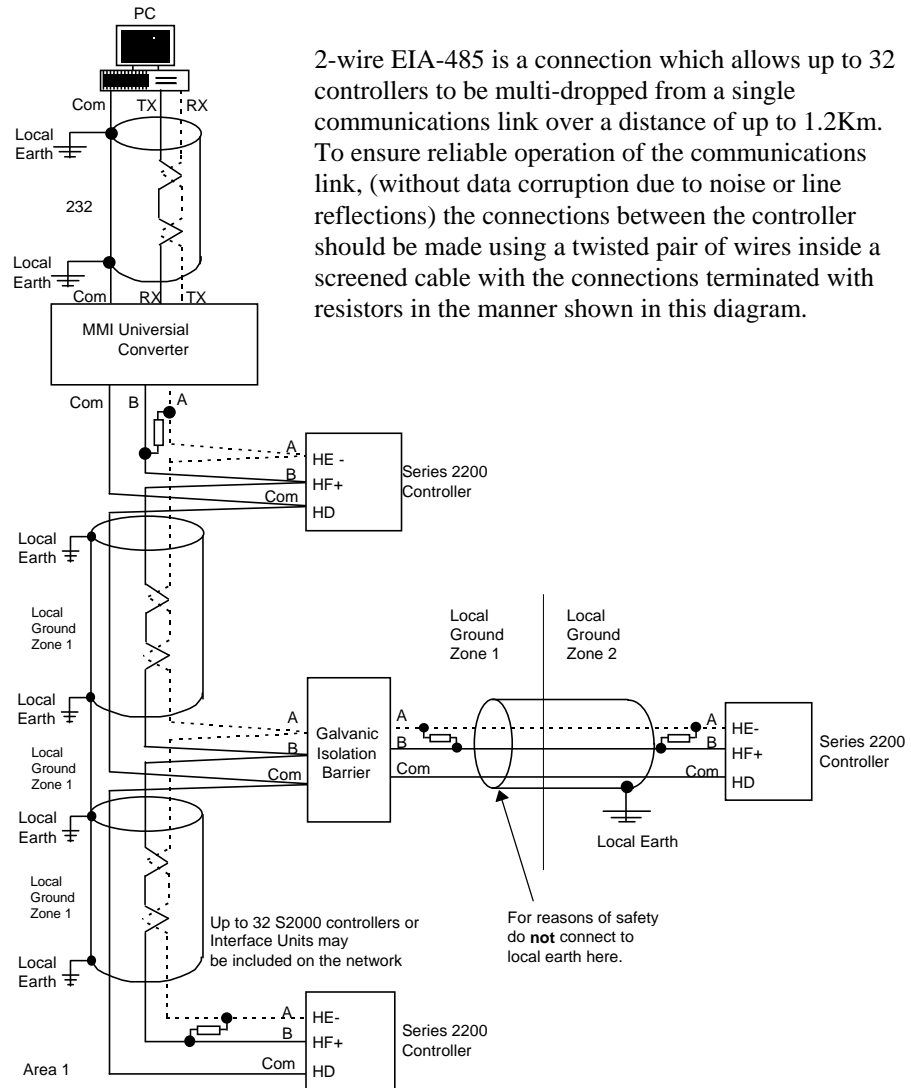

Note:
 All resistors are 220 ohm 1/4W carbon composition.
 Local grounds are at equipotential. Where equipotential is not available wire into separate zones using a galvanic isolator.
 Use a repeater (KD845) for more than 32 units.

Figure 9 EIA-485 wiring

Marathon Monitors Inc.

This sheet intentionally left blank

OPERATION

This chapter has nine topics:

- FRONT PANEL LAYOUTS
- BASIC OPERATION
- OPERATING MODES
- AUTOMATIC MODE
- MANUAL MODE
- PARAMETERS AND HOW TO ACCESS THEM
- NAVIGATION DIAGRAM
- PARAMETER TABLES
- ALARMS

FRONT PANEL LAYOUTs

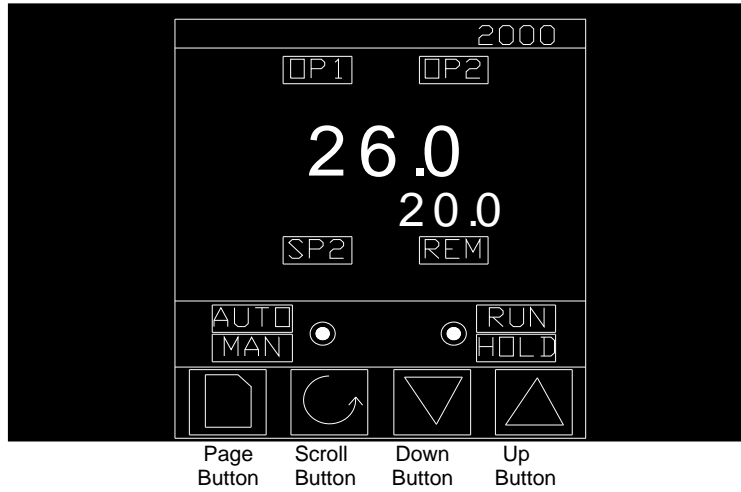

Figure 10 Model AACC 2200 front panel layout

Marathon Monitors Inc.







Button or indicator	Name	Explanation
OP1	Output 1	When lit, it indicates that the output installed in module position 1 is on. This is normally the heating output on a temperature controller.
OP2	Output 2	When lit, it indicates that the output installed in module position 2 is on. This is normally the cooling output on a temperature controller.
SP2	Setpoint 2	When lit, this indicates that setpoint 2, (or a setpoint 3-16) has been selected.
REM	Remote setpoint	When lit, this indicates that a remote setpoint input has been selected. 'REM' will also flash when communications is active.
	Auto/Manual button	When pressed, this toggles between automatic and manual mode: <ul style="list-style-type: none"> • If the controller is in automatic mode the AUTO light will be lit. • If the controller is in manual mode, the MAN light will be lit. The Auto/Manual button can be disabled in configuration level.
	Run/Hold button	<ul style="list-style-type: none"> • Press once to start an automatic Probe care cycle • This RUN light indicates when ever a probe care function is in progress
	Page button	Press to select a new list of parameters.
	Scroll button	Press to select a new parameter in a list.
	Down button	Press to decrease a value in the lower readout.
	Up button	Press to increase a value in lower readout.

Figure 11 Controller buttons and indicators

Basic operation

Switch on the power to the controller. It runs through a self-test sequence for about three seconds and then shows the process value, in the upper readout and the *setpoint*, in the lower readout. This is called the **Home** display.

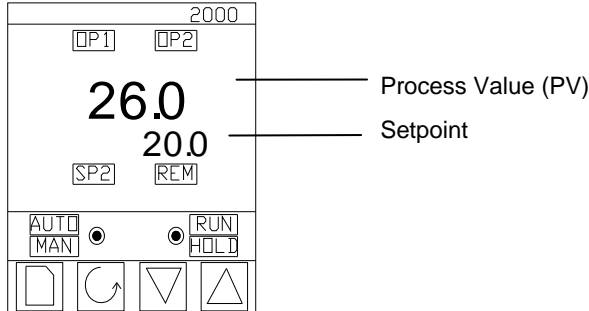





Figure 12 Home display

You can adjust the setpoint by pressing the  or  buttons. Two seconds after releasing either button, the display blinks to show that the controller has accepted the new value.

OP1 will light whenever output 1 is ON. This is normally the heating output when used as a temperature controller.

OP2 will light whenever output 2 is ON. This is normally the cooling output when used as a temperature controller.

Note: You can get back to this display at any time by pressing  and  together. Alternatively, you will always be returned to this display if no button is pressed for 45 seconds, or whenever the unit is powered-up.

Alarms

If the controller detects an alarm condition, it flashes an alarm message in the Home display. For a list of all the alarm messages, their meaning and what to do about them, see *Alarms* at the end of this chapter.

OPERATING MODES

The controller has two basic modes of operation:

- **Automatic mode** in which the output is automatically adjusted to maintain the temperature or process value at the setpoint.
- **Manual mode** in which you can adjust the output independent of the setpoint.

You toggle between the modes by pressing the AUTO/MAN button. The displays which appear in each of these modes are explained in this chapter.

Automatic mode

You will normally work with the controller in automatic mode. If the MAN light is on, press the AUTO/MAN button to select automatic mode. The AUTO light comes on

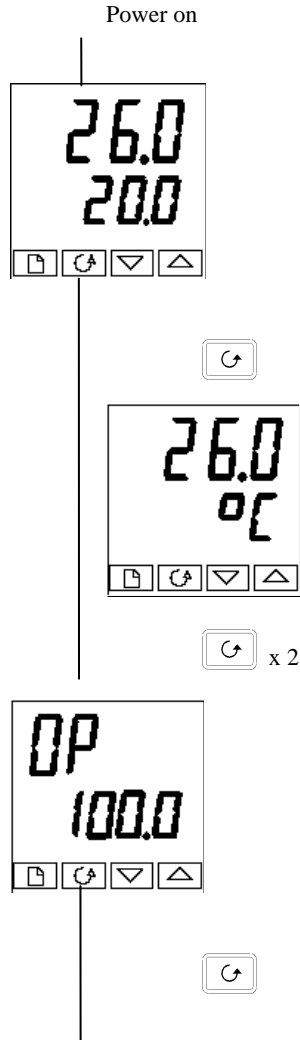

The Home display

Check that the AUTO light is on.

The upper readout shows the measured temperature.

The lower readout shows the setpoint.

To adjust the setpoint up or down, press

▲ or ▼.

(Note: If Setpoint Rate Limit has been enabled, then the lower readout will show the active setpoint. If ▲ or ▼ is pressed, it will change to show and allow adjustment of, the target setpoint.)

Press  once



Display units

A single press of  will flash the display units for 0.5 seconds, after which you will be returned to the Home display. Flashing of the display units may have been disabled in configuration in which case a single press will take you straight to the display shown below.

Press  twice

% Output power demand

The % output power demand is displayed in the lower readout. This is a read-only value. You cannot adjust it.

Press  and  together to return to the Home display.

Pressing  from the Output Power display may access further parameters. These may be in this scroll list if the 'Promote' feature has been used (see Chapter 3, *Access Level*).

When you reach the end of this scroll list, pressing  will return you to the **Home** display.

MANUAL MODE

If the AUTO light is on, press the AUTO/MAN button to select manual mode. The MAN light comes on.

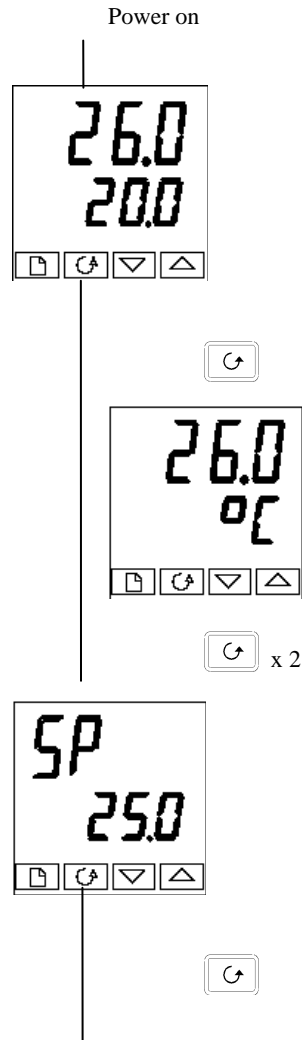

The Home display

Check that the MAN light is on.

The upper readout shows the measured temperature, or process value. The lower readout shows the % output.

To adjust the output, press ▲ or ▼.

(Note: If Output Rate Limit has been enabled, then the lower readout will show the working output. If ▲ or ▼ is pressed, it will change to show and allow adjustment of the target output.)

Press the refresh button once.

Display units

A single press of the refresh button flashes the display units for 0.5 seconds, after which you are returned to the Home display.

Flashing of the display units may have been disabled in configuration, in which case a single press will take you straight to the display shown below.

Press the refresh button twice.

Setpoint

To adjust the setpoint value, press ▲ or ▼.

Press the scroll list button.

Pressing the scroll list button from the Output Power display may access further parameters. These may be in this scroll list if the 'Promote' feature has been used (see Chapter 3, *Edit Level*). When you reach the end of this scroll list, pressing the refresh button will return you to the **Home** display.

PARAMETERS AND HOW TO ACCESS THEM

Parameters are settings, that determine how the controller will operate. For example, alarm setpoints are parameters that set the points at which alarms will occur. For ease of access, the parameters are arranged in lists as shown in the navigation diagram on Pages 2-10 and 2-11. The lists are:

Home list	Autotune list	Output list
Probe list	PID list	Communications list
Care list	Motor list	Information list
User list	Setpoint list	Access list.
Alarm list	Input list	

Each list has a 'List Header' display.

List header displays

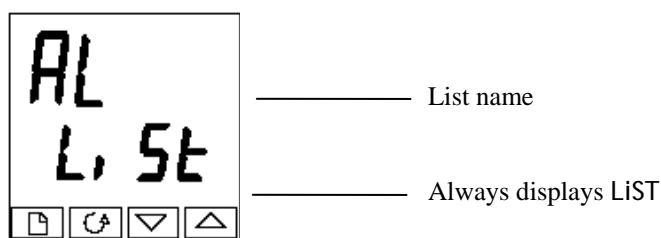



Figure 13 Typical list header display

A list header can be recognized by the fact that it always shows 'LiSt' in the lower readout. The upper readout is the name of the list. In the above example, 'AL' indicates that it is the Alarm list header. List header displays are read-only.

To step through the list headers, press . Depending upon how your controller has been configured, a single press may momentarily flash the display units. If this is the case, a double press will be necessary to take you to the first list header. Keep pressing to step through the list headers, eventually returning you to the Home display.

To step through the parameters within a particular list, press . When you reach the end of the list, you will return to the list header. From within a list you can

Marathon Monitors Inc.

return to the current list header at any time can by pressing  . To step to the next list header, press  once again.

Parameter names

In the navigation diagram, each box shows the display for a selected parameter. The Operator parameter tables, later in this chapter, list all the parameter names and their meanings.

The navigation diagram shows all the parameters that can, potentially, be present in the controller. In practice, a limited number of them appear, as a result of the particular configuration.

The shaded boxes in the diagram indicate parameters that are hidden in normal operation. To view all the available parameters, you must select Full access level. For more information about this, see Chapter 3, Access Levels. Parameter displays Each list has a 'List Header' display.

Parameter displays

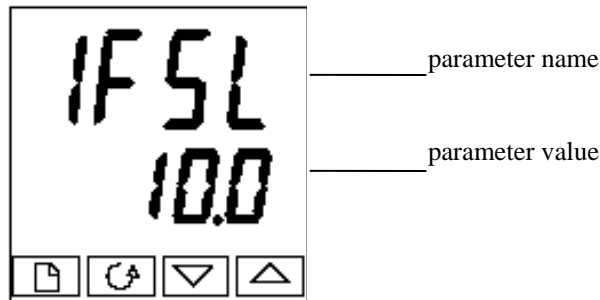



Figure 14 Typical parameter display

Parameter displays show the controller's current settings. The layout of parameter displays is always the same: the upper readout shows the parameter name and the lower readout its value. In the above example, the parameter name is 1FSL (indicating Alarm 1, full scale low), and the parameter value is 10.0.

To change the value of a parameter

First, select the required parameter.

To change the value, press either  or . During adjustment, single presses change the value by one digit.

Keeping the button pressed speeds up the rate of change.

Marathon Monitors Inc.

Two seconds after releasing either button, the display blinks to show that the controller has accepted the new value.

Marathon Monitors Inc.

Navigation Diagram (Part A) (THE PARAMETERS THAT APPEAR DEPEND UPON HOW THE CONTROLLER HAS BEEN CONFIGURED)

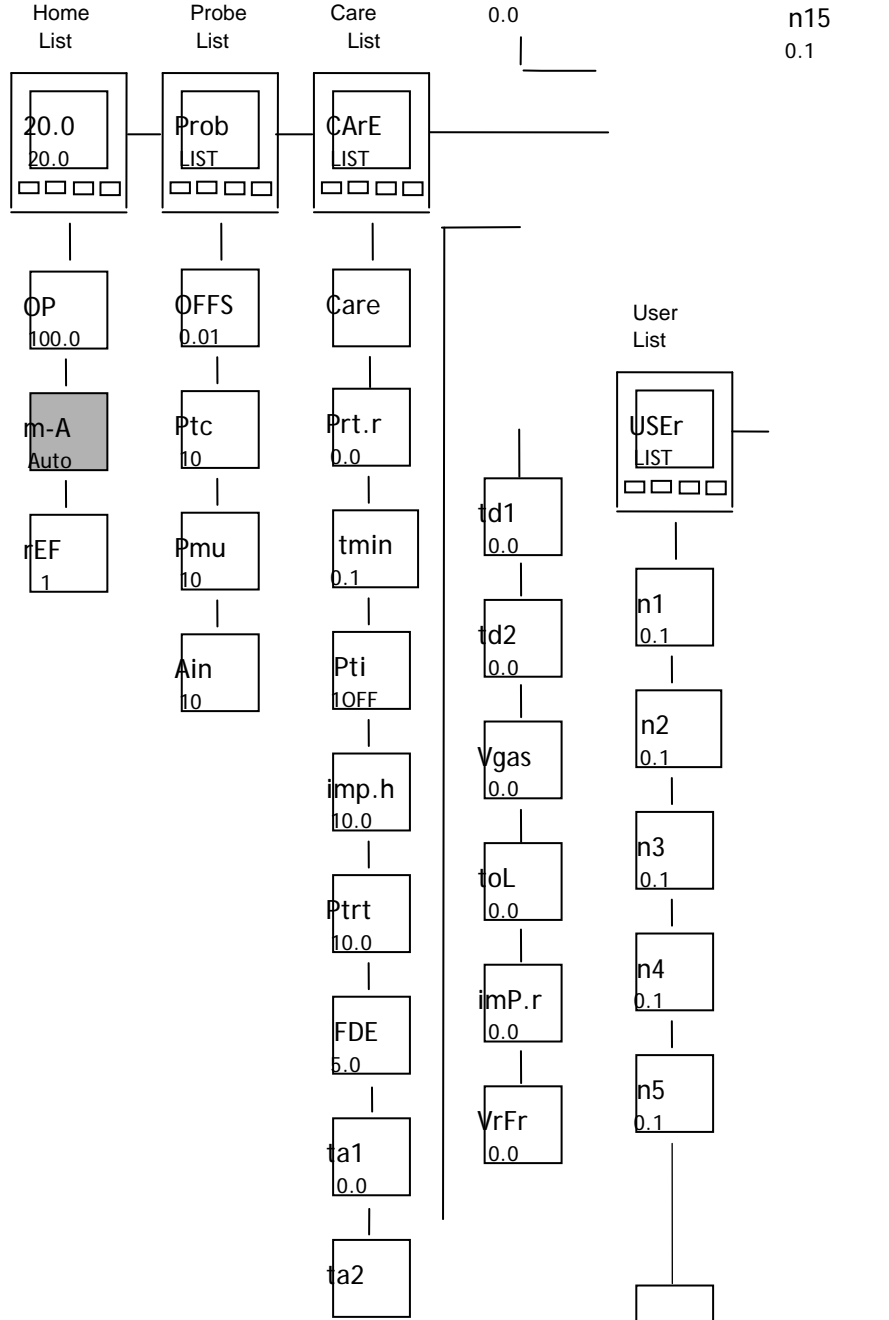

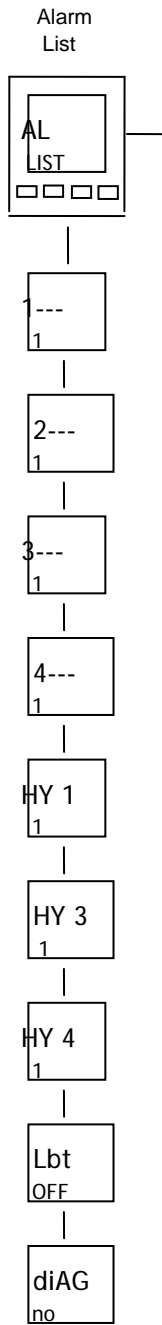

Marathon Monitors Inc.

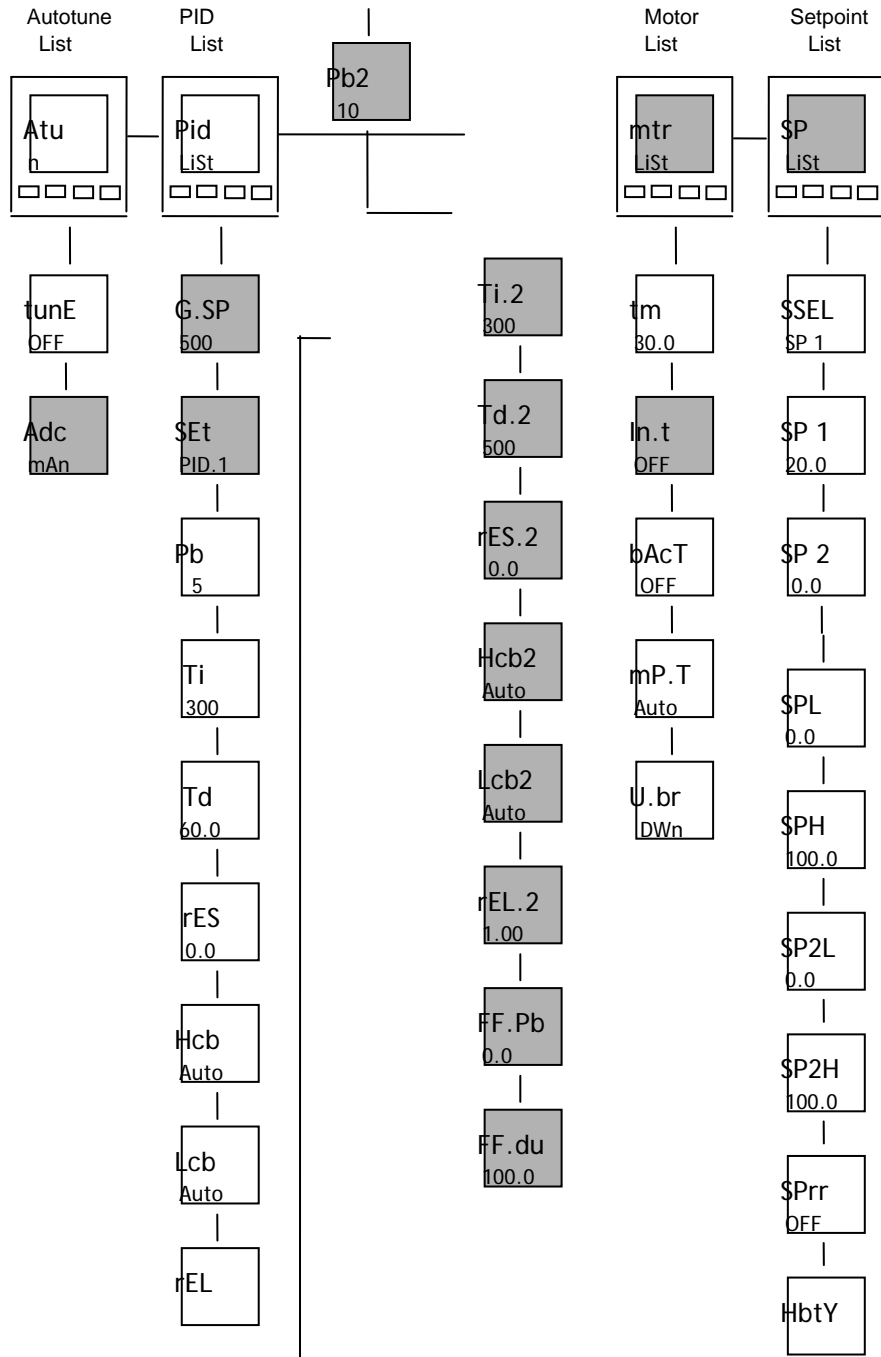

Marathon Monitors Inc.

OFF

Marathon Monitors Inc.

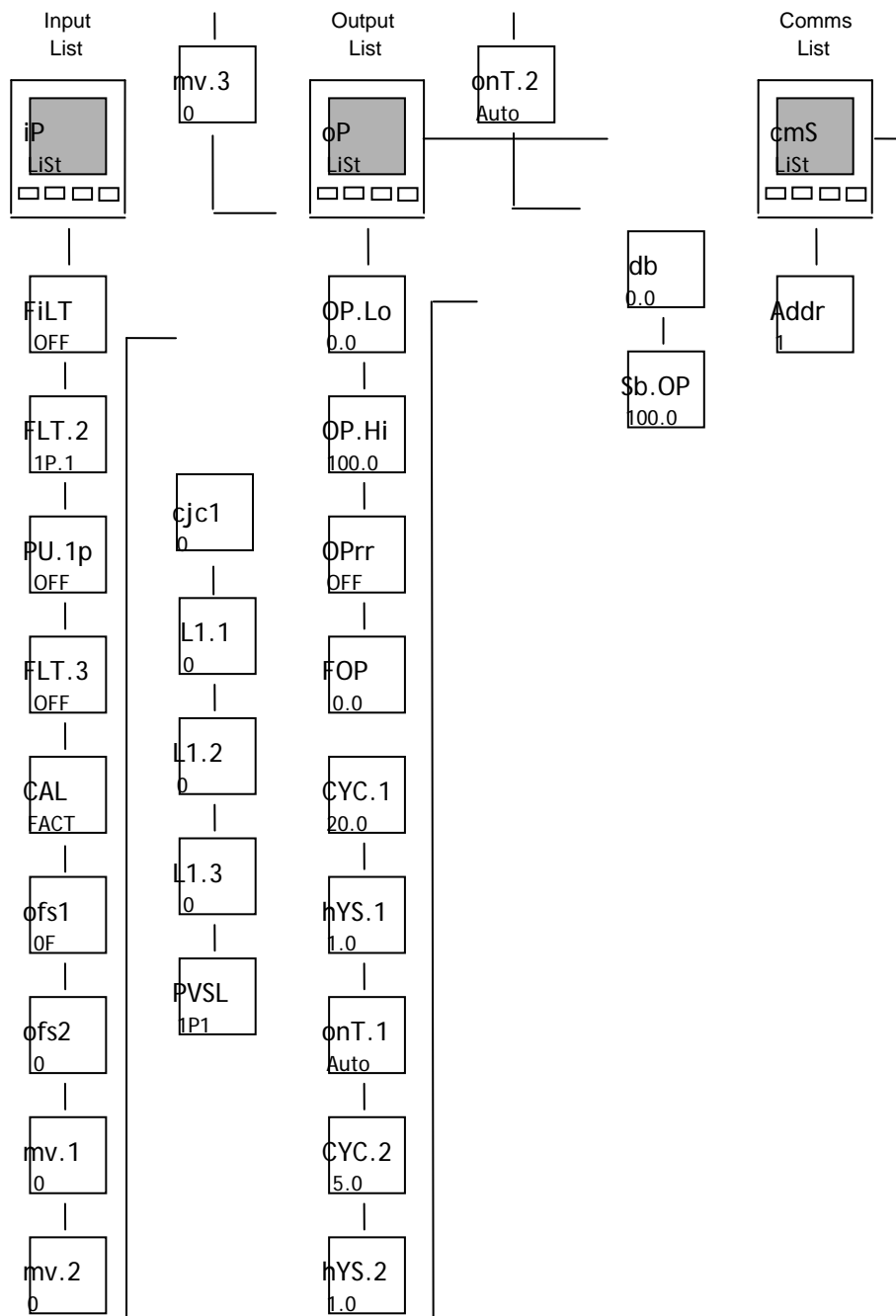

Marathon Monitors Inc.

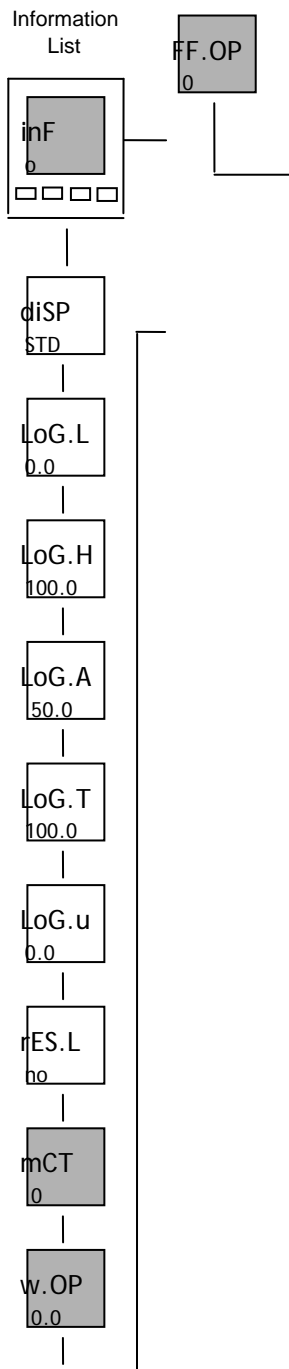

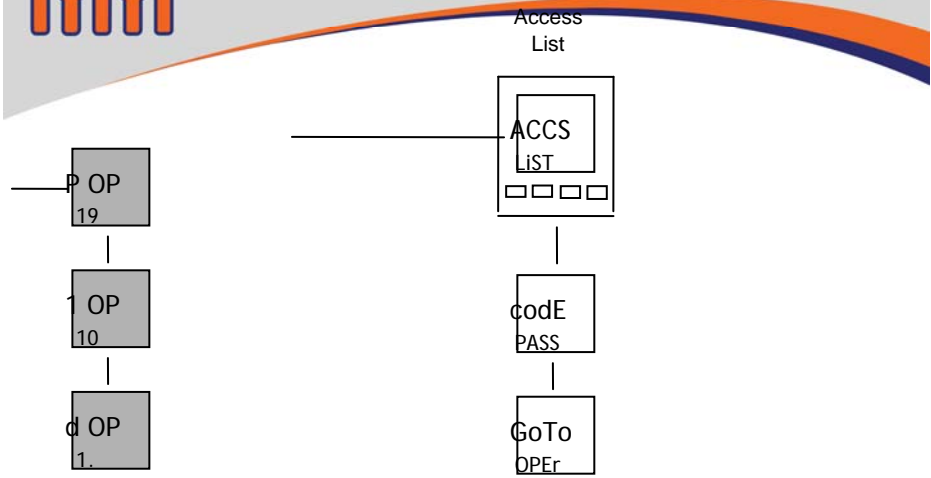

Marathon Monitors Inc.

PARAMETER TABLES

Name	* = Default	Description
------	-------------	-------------

Home list		
Home		Measured value and Setpoint
OP		% Output level
SP		Target setpoint (if in Manual mode)
m-A		Auto-man select
reF		Customer defined identification number
+ Extra parameters, if the 'Promote' feature has been used (see Chapter 3, <i>Edit Level</i>).		

Name	* = Default	Description
------	-------------	-------------

Probe list		
Prob		Probe list
OFFS	*0.0	Millivolt input OFFSET
PTc		Probe Temperature
Pmu		Probe millivolts
Ain		AUX input

Name	* = Default	Description
------	-------------	-------------

Care list		
Care		Care list
Care	*OFF	Probe care operation selection
Prtr		MSI actual Probe recovery time
Tmin	*OFF	Minimum temperature for care procedure
Pti	*OFF	Probe care cycle time
imp.H	*20.0	Maximum probe impedance
Pprt	*30.0	Impedance test recovery time
FdE	*5.0	Final delay time
tA1	*1.0	Verification average time 1
tA2	*1.0	Verification average time 2
td1	*30.0	Verification delay time 1
td2	*30.0	Verification delay time 2
Vgas	*10.0	Verification reference gas mlevel
ToL	*2.0	Verification test tolerance
t2c		Time to next care
imp.r		impedance test result
Vfr		Verification test result

Marathon Monitors Inc.

Name	* = Default	Description
User		
User list		
n1		user parameter #1
n2		user parameter #2
n3		user parameter #3
n4		user parameter #4
n5-15		user parameter #5 - 15

Name	* = Default	Description
AL		
Alarm list		
1 - - -		Alarm 1 setpoint value
2 - - -		Alarm 2 setpoint value
3 - - -		Alarm 3 setpoint value
4 - - -		Alarm 4 setpoint value
<i>In place of dashes, the last three characters indicate the alarm type. See alarm types table:</i>		
HY 1		Alarm 1 Hysteresis (display units)
HY 2		Alarm 2 Hysteresis (display units)
HY 3		Alarm 3 Hysteresis (display units)
HY 4		Alarm 4 Hysteresis (display units)
Lb t		Loop Break Time in minutes
diAG		Enable Diagnostic alarms 'no' / 'YES'
Alarm types table		
-FSL		PV Full scale low alarm
-FSH		PV Full scale high alarm
-dEv		PV Deviation band alarm
-dHi		PV Deviation high alarm
-dLo		PV Deviation low alarm
-LCr		Load Current low alarm
-HCr		Load Current high alarm
-FL2		Input 2 Full Scale low alarm
-FH2		Input 2 Full Scale high alarm
-LOP		Working Output low alarm
-HOP		Working Output high alarm
-LSP		Working Setpoint low alarm
-HSP		Working Setpoint high alarm
4rAt		Rate of change alarm (<i>AL 4 only</i>)

Marathon Monitors Inc.

Atun	Autotune list
tunE	One-shot autotune enable
drA	Adaptive tune enable
drA.t	Adaptive tune trigger level in display units. Range = 1 to 9999
Adc	Automatic Droop Compensation (PD control only)

Marathon Monitors Inc.

Name	* = Default	Description
Pid		
PID list		
G.SP		If Gain Scheduling has been enabled (see Chapter 4), this parameter sets the PV below which 'Pid.1' is active and above which 'Pid.2' is active.
SEt		'Pid.1' or 'Pid.2' selected
Pb		Proportional Band (SEt 1) (in display units)
ti		Integral Time in secs (SEt 1)
td		Derivative Time in secs (SEt 1)
rES		Manual Reset (%) (SEt 1)
Hcb		Cutback High (SEt 1)
Lcb		Cutback Low (SEt 1)
rEL.C		Relative Cool Gain (SEt 1)
Pb2		Proportional Band (SEt 2)
ti2		Integral Time in secs (SEt 2)
td2		Derivative Time in secs (SEt 2)
rES.2		Manual Reset (%) (SEt 2)
Hcb2		Cutback High (SEt 2)
Lcb2		Cutback Low (SEt 2)
rEL.2		Relative Cool Gain (SEt 2)
<i>The following three parameters are used for cascade control. If this facility is not being used, then they can be ignored.</i>		
FF.Pb		SP, or PV, feedforward propband
FF.tr		Feedforward trim %
FF.dv		PID feedforward limits \pm %
mtr		
Motor list - see Table 4-3		
tm		Valve travel time in seconds
In.t		Valve inertia time in secs
bAc.t		Valve backlash time in secs
mp.t		Minimum ON time of output pulse
U.br		Valve sensor break strategy

Marathon Monitors Inc.

Name	* = Default	Description
SP		
Setpoint list		
SSEL	*SP.1	Select SP 1 to SP16, depending on configuration
SP 1		Setpoint one value
SP 2		Setpoint two value
SP L	*0.0	Setpoint 1 low limit
SP H	*30.0	Setpoint 1 high limit
SP2.L	*0.0	Setpoint 2 low limit
SP2.H	*30.0	Setpoint 2 high limit
SPrr		Setpoint Rate Limit
Hb.ty		Holdback Type for setpoint rate limit (OFF, Lo, Hi, or bAnd)

iP		
Input list		
FiLt	*1.6	IP1 filter time constant (0.0 - 999.9 seconds).
FLt.2		IP2 filter time constant (0.0 - 999.9 seconds).
PV.ip		Selects 'ip.1' or 'ip.2'
FLt.3		DC input Filter Time Constant
CAL		User Calibration Enable
OFS.1	*0.0	simple offset
OFS.2	*0.0	PV2 simple offset
mV.1		ADC Converter millivolts
mV.2		ADC Converter millivolts PV2
mV.3		Second PV millivolts input
CJC.1		IP1 cold junction temp. reading
CJC.2		IP2 cold junction temp. reading
Li.1		IP1 linearised value
Li.2		IP2 linearised value
Li.3		DC Input 3
PV.SL		Current Input or Inputs used for PV

Marathon Monitors Inc.

Name	* = Default	Description
oP		
Output list		
<i>Does not appear if Motorised Valve control configured.</i>		
OP.Lo	*-100	Low power limit (%)
OP.Hi	*100	High power limit (%)
Oprr	*0.0	Output Rate Limit (% per sec)
FOP	*0.0	Forced output level (%)
CYC.H	*100	Heat cycle time (0.2S to 999.9S)
hYS.H		Heat hysteresis (display units)
ont.H	*AUTO	Heat output min. on-time (secs) Auto (0.05S), or 0.1 - 999.9S
CYC.C		Cool cycle time (0.2S to 999.9S)
hYS.C		Cool hysteresis (display units)
ont.C		Cool output min. on-time (secs) Auto (0.05S), or 0.1 - 999.9S
HC.db		Heat/cool deadband (display units)
Sb.OP	*0.0	Sensor Break Output Power (%)

cmS		Comms list
Addr	*1	Communications Address

inFo		Information list
diSP		Configure lower readout of Home display to show: VPos Valve position Std Standard - display setpoint AmPS Load current in amps OP Output Stat Program status PrG.t Program time remaining in hours Li 2 Process value 2 rAt Ratio setpoint PrG Selected program number rSP Remote setpoint
LoG.L		PV minimum
LoG.H		PV maximum
LoG.A		PV mean value
Log.t		Time PV above Threshold level
Log.v		PV Threshold for Timer Log

Marathon Monitors Inc.

Name	* = Default	Description
inFo		Information list - <i>continued</i>
rES.L		Logging Reset - 'YES/no'
<i>The following set of parameters is for diagnostic purposes.</i>		
mCt		Processor utilisation factor
w.OP		Working output
FF.OP		Feedforward component of output
VO		PID output to motorised valve
P OP		Proportional component of output
I OP		Integral component of output
d OP		Derivative component of output

ACCS	Access List
codE	Access password
Goto	Goto level - OPEr, FuLL, Edit or conF
ConF	Configuration password

Probe Verification and Impedance Test

The Oxygen monitor and/or controller will have the probe verification test and the probe impedance test. The operator could select to have the probe verification and impedance test performed together. If so, the probe verification will be first and then the probe impedance test. The impedance test will be performed independent of the verification results.

Probe Verification

Probe verification is performed by determining if the probe can correctly identify a known gas by using the process as a reference. The verification process must be done during a time period when the process is not subject to a large upset. The several readings are averaged to eliminate normal process variations. The first operator input is the time period (in seconds) over which the process is averaged (T_a). The second operator input would be a delay time (in seconds) between when the contact closure is made to switch the reference gas and the second set of reading start and also when the contact is opened (T_d). The third operator input is the time (in minutes) between automatic verifications. Setting the time between automatic tests to zero disables the automatic feature. A method of manually initiating a test is also required. The four operator input is the amount of oxygen in the reference gas in percent (0 to 100.0 %). The fifth operator input is the tolerance which is specified in the same units as the displayed %O₂ (i.e. %, PPM, etc).

The verification test consists of five stages. The first stage is averaging the process for time T_a . The second stage is closing the contact for the reference gas and waiting time T_d for the probe to settle. The third stage is average the reading with the reference gas for time T_a . The fourth stage is opening the contact to discontinue the reference gas and wait for the probe to recover. The fifth stage is to average the process again as a check value. At the end of the fifth stage, the results are analyzed. If the first process average and the check (third) average do not agree within the specified tolerance, then the test is declared invalid. If the first and check averages do not agree then the process either drifted or is too noisy. If they agree then the value of the reference gas is computed based on the second

Marathon Monitors Inc.

average and stored as the result of this test. The result is then compared to the operator input value of the reference. If these agree within the tolerance, then the probe is declared good. Otherwise it is declared bad. This good/bad result should be assignable to an alarm contact.

```
*****                               *****
*                                     *
Process                               *
*
*****
|  1      |2|      3      |4|      5      |      Stage
|  Ta     |Td|     Ta     |Td|     Ta     |      Time
|
|                                     |
Contact closes      Contact opens
```

Probe Impedance Test

The probe impedance test is performed by measuring the open circuit voltage of the probe, applying a known shunt resistor and measuring the shunted value. The impedance is calculated as:

$$R_x = (E_o/E_s - 1) * R_s$$

where: R_x = probe impedance, E_o = open circuit voltage, E_s = shunted voltage, and R_s = shunt resistor. Since the voltage units drop out, the voltage could be in volts, millivolts, or A/D counts. The units of R_x are the same as R_s ; therefore, the calculation is the same for $R_s = 10 \text{ kohm}$ or $R_s = 10 \text{ ohm}$.

Marathon Monitors Inc.



<u>Sequence #</u>	<u>Description</u>
1	Inhibit process variable calculations and control calculations. Hold output power at last value. Freeze alarms at last state. Store present millivolt reading. Apply shunt resistor across probe.
2	Wait for impedance test timer, fixed time of 30 Seconds
3	Compute impedance of probe and remove shunt resistor
4	Wait for probe to recover to $\geq 90\%$ of original millivolts. Maximum wait time for recovery is set by operator. Store recovery time (or max value)
5	If burn off is to be performed then go to first step of burn off sequence, otherwise wait 30 seconds.
6	Resume normal operation of all instrument functions.

Alarms

Alarm annunciation

Alarms are flashed as messages in the Home display. A new alarm is displayed as a double flash followed by a pause, old (acknowledged) alarms as a single flash followed by a pause. If there is more than one alarm condition, the display cycles through all the relevant alarm messages. Table 2-1 and Table 2-2 list all of the possible alarm messages and their meanings.

Alarm acknowledgement and resetting

Pressing both  and  at the same time will acknowledge any new alarms and reset any latched alarms.

Alarm modes

Alarms will have been set up to operate in one of several modes, either:

- **Non-latching**, which means that the alarm will reset automatically when the Process Value is no longer in the alarm condition.
- **Latching**, which means that the alarm message will continue to flash even if the alarm condition no longer exists and will only clear when reset.
- **Blocking**, which means that the alarm will only become active after it has first entered a safe state on power-up.

Alarm types

There are **two** types of alarm: **Process alarms** and **Diagnostic alarms**.

Process alarms

These warn that there is a problem with the process which the controller is trying to control.

Alarm Display	What it means
_FSL*	PV Full Scale Low alarm
_FSH*	PV Full Scale High alarm
_dEv*	PV Deviation Band alarm
_dHi*	PV Deviation High alarm
_dLo*	PV Deviation Low alarm
_LCr*	Load Current Low alarm
p.FLT	Probe impedance test fault.

Alarm Display	What it means
_FL2*	Input 2 Full Scale Low alarm
_FH2*	Input 2 Full Scale High alarm
_LOP*	Working Output Low alarm
_HOP*	Working Output High alarm
_LSP*	Working Setpoint Low alarm
V.FLT	Verification test fault

** In place of the dash, the first character will indicate the alarm number.*

Table 2-1 Process alarms

Marathon Monitors Inc.

Diagnostic alarms

These indicate that a fault exists in either the controller or the connected devices.

Display shows	What it means	What to do about it
EE.Er	<i>Electrically Erasable Memory Error:</i> The value of an operator, or configuration parameter has been corrupted.	This fault will automatically take you into Configuration level. Check all of the configuration parameters before returning to Operator level. Once in Operator level, check all of the operator parameters before resuming normal operation. If the fault persists, or occurs frequently, contact MSI Controls. (see inside of cover)
S.br	<i>Sensor Break:</i> Input sensor is unreliable or the input signal is out of range.	Check that the sensor is correctly connected.
L.br	<i>Loop Break</i> The feedback loop is open circuit.	Check that the heating and cooling circuits are working properly.
Hw.Er	<i>Hardware error</i> Indication that a module is of the wrong type, missing, or faulty.	Check that the correct modules are fitted.
no.io	<i>No I/O</i> None of the expected I/O modules is fitted.	This error message normally occurs when pre-configuring a controller without installing any of the required I/O modules.
rmt.F	<i>Remote input failure.</i> the remote DC input, is open or short circuit	Check for open, or short circuit wiring on the remote DC input.
LLLL	<i>Out of range low reading</i>	Check the value of the input.
HHHH	<i>Out of range high reading</i>	Check the value of the input.
Err1	<i>Error 1: ROM self-test fail</i>	Return the controller for repair.
Err2	<i>Error 2: RAM self-test fail</i>	Return the controller for repair.
Err3	<i>Error 3: Watchdog fail</i>	Return the controller for repair.
Err4	<i>Error 4: Keyboard failure</i> Stuck button, or a button was pressed during power up.	Switch the power off and then on, without touching any of the controller buttons.
Err5	<i>Error 5: Faulty internal communications.</i>	Check printed circuit board interconnections. If the fault cannot be cleared, return the controller for repair.

ACCESS LEVELS

This chapter describes the different levels of access to the operating parameters within the controller.

There are three topics:

- THE DIFFERENT ACCESS LEVELS
- SELECTING AN ACCESS LEVEL
- EDIT LEVEL

THE DIFFERENT ACCESS LEVELS

There are four access levels:

- **Operator level**, which you will normally use to operate the controller.
- **Full level**, which is used to commission the controller.
- **Edit level**, which is used to set up the parameters that you want an operator to be able to see and adjust when in Operator level.
- **Configuration level**, which is used to set up the fundamental characteristics of the controller.

Access level	Display shows	What you can do	Password Protection
Operator	OPeR	In this level, operators can view and adjust the value of parameters defined in Edit level (see below).	No
Full	FuLL	In this level, all the parameters relevant to a particular configuration are visible. All alterable parameters may be adjusted.	Yes
Edit	Edit	In this level, you can determine which parameters an operator is able to view and adjust in Operator level. You can hide, or reveal, complete lists, individual parameters within each list and you can make parameters read-only or alterable. (See <i>Edit level</i> at the end of this chapter).	Yes
Configuration	conF	This special level allows access to set up the fundamental characteristics of the controller.	Yes

Figure 16 Access levels

SELECTING AN ACCESS LEVEL

Marathon Monitors Inc.

Access to Full, Edit or Configuration levels is protected by a password to prevent unauthorised access.

If you need to change the password, see Chapter 6, *Configuration*.

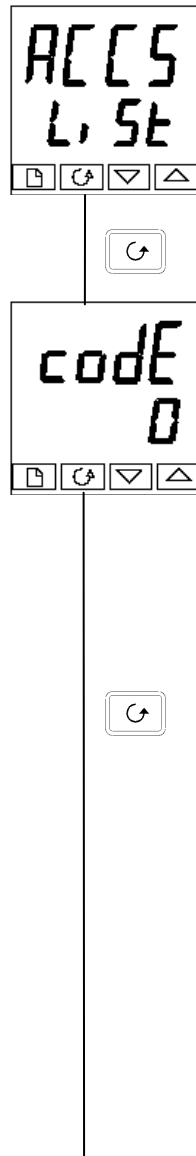

Access list header

Press until you reach the access list header 'ACCS'.

Press

Password entry

The password is entered from the 'code' display. Enter the password using or . Once the correct password has been entered, there is a two second delay after which the lower readout will change to show 'PASS' indicating that access is now unlocked.

The pass number is set to '1' when the controller is shipped from the factory.

Note: A special case exists if the password has been set to '0'. In this case access will be permanently unlocked and the lower readout will always show 'PASS'.

Press to proceed to the 'Goto' page.

(If an *incorrect* password has been entered and the controller is still 'locked' then pressing returns you to the 'ACCS' list header.)

Access to Read-only Configuration

From this display, pressing and together will take you into Read-Only Configuration without entering a password. This will allow you to view all of the configuration parameters, but not adjust them. If no button is pressed for ten seconds, you will be returned to the Home display. Alternatively, pressing and together takes you immediately back to the Home display





Alternative path if
'conF' selected



Level selection

The 'Goto' display allows you to select the required access level.

Use  and  to select from the following display codes:

OPER: Operator level
FULL: Full level
Edit: Edit level
conF: Configuration level

Press 

If you selected either 'OPER', 'FULL' or 'Edit' level you will be returned to the 'ACCS' list header in the level that you chose. If you selected 'conF', you will get a display showing 'CONF' in the upper readout (see below).

Configuration password

When the 'CONF' display appears, you must enter the Configuration password in order to gain access to this level. Do this by repeating the password entry procedure described in the previous section.

The configuration password is set to '2' when the controller is shipped from the factory. If you need to change the configuration password, see Chapter 6, *Configuration*.

Press 

Configuration level

The first display of configuration is shown. See Chapter 6, *Configuration*, for details of the configuration parameters, and provide instructions on leaving configuration level,

Returning to Operator Level

To return to operator level from either 'FULL' or 'Edit' level, repeat entry of the password and select 'OPER' on the 'Goto' display.



In 'Edit' level, the controller will automatically return to operator level if no button is pressed for 45 seconds.

Edit level



Edit level is used to set which parameters you can view and adjust in Operator level. It also gives access to the 'Promote' feature, which allows you to select and add ('Promote') up to twelve parameters into the Home display list, thereby giving simple access to commonly used parameters.

Setting operator access to a parameter

First you must select Edit level, as shown on the previous page.

Once in Edit level, you select a list, or a parameter within a list, in the same way as you would in Operator, or Full, level – that is to say, you move from list header to list header by pressing , and from parameter to parameter within each list using .

However, in Edit level what is displayed is not the value of a selected parameter, but a code representing that parameter's availability in Operator level.

When you have selected the required parameter, use  and  buttons to set its availability in Operator level.

There are four codes:

- ALtr** Makes a parameter alterable in Operator level.
- PrO** Promotes a parameter into the Home display list.
- rEAd** Makes a parameter, or list header, read-only (*it can be viewed but not altered*).
- HIde** Hides a parameter, or list header.

For example:



The parameter selected is Alarm 2, Full Scale Low

It will be alterable in Operator level

Hiding or revealing a complete list

To hide a complete list of parameters, all you have to do is hide the list header. If a list header is selected, only two selections are available: rEAd and HIde.

(It is not possible to hide the 'ACCS' list, which always displays the code: 'LiSt'.)

Promoting a parameter

Scroll through the lists to the required parameter and choose the 'PrO' code. The parameter is then automatically added (promoted) into the Home display list. (The parameter will also be accessible, as normal, from the standard lists.) A maximum of twelve parameters can be promoted. Promoted parameters are automatically 'alterable'.

TUNING

Before tuning, please read Chapter 2, *Operation*, to learn how to select and change a parameter.

This chapter has five topics:

- WHAT IS TUNING?
- AUTOMATIC TUNING
- MANUAL TUNING
- COMMISSIONING OF MOTORISED VALVE CONTROLLERS
- GAIN SCHEDULING

WHAT IS TUNING?

In tuning, you match the characteristics of the controller to those of the process being controlled in order to obtain good control. Good control means:

- Stable, 'straight-line' control of the process variable at setpoint without fluctuation
- No overshoot, or undershoot, of the process variable setpoint
- Quick response to deviations from the setpoint caused by external disturbances, thereby rapidly restoring the process variable to the setpoint value.

Tuning involves calculating and setting the value of the parameters listed in Table 4-1. These parameters appear in the 'Pid' list.

Parameter	Code	Meaning or Function
Proportional band	Pb	The bandwidth, in display units, over which the output power is proportioned between minimum and maximum.
Integral time	ti	Determines the time taken by the controller to remove steady-state error signals.
Derivative time	td	Determines how strongly the controller will react to the rate-of-change of the measured value.
High Cutback	Hcb	The number of display units, above setpoint, at which the controller will increase the output power, in order to prevent undershoot on cool down.
Low cutback	Lcb	The number of display units, below setpoint, at which the controller will cutback the output power, in order to prevent overshoot on heat up.
Relative cool gain	rEL	Only present if cooling has been configured and a module is fitted. Sets the cooling proportional band, which equals the Pb value divided by the rEL value.

AUTOMATIC TUNING

Two automatic tuning methods are provided in the AACC 2200:

- **A one-shot tuner**, which automatically sets up the initial values of the parameters listed in Table 4-1 on the previous page.
- **Adaptive tuning**, which continuously monitors the error from setpoint and modifies the PID values, if necessary.

One-shot Tuning

The 'one-shot' tuner works by switching the output on and off to induce an oscillation in the measured value. From the amplitude and period of the oscillation, it calculates the tuning parameter values.

If the process cannot tolerate full heating or cooling being applied during tuning, then the level of heating or cooling can be restricted by setting the heating and cooling power limits in the 'oP' list. However, the measured value *must* oscillate to some degree for the tuner to be able to calculate values.

A One-shot Tune can be performed at any time, but normally it is performed only once during the initial commissioning of the process. However, if the process under control subsequently becomes unstable (because its characteristics have changed), you can re-tune again for the new conditions.

It is best to start tuning with the process at ambient process variable. This allows the tuner to calculate more accurately the low cutback and high cutback values which restrict the amount of overshoot, or undershoot.

How to tune

1. Set the setpoint to the value at which you will normally operate the process.
2. In the 'Atun' list, select 'tunE' and set it to 'on'.
3. Press the Page and Scroll buttons together to return to the Home display. The display will flash 'tunE' to indicate that tuning is in progress.
4. The controller induces an oscillation in the process variable by first turning the heating on, and then off. The first cycle is not complete until the measured value has reached the required setpoint.
5. After two cycles of oscillation the tuning is completed and the tuner switches itself off.
6. The controller then calculates the tuning parameters listed in Table 4-1 and resumes normal control action.

If you want 'Proportional only', 'PD', or 'PI' control, you should set the 'ti' or 'td' parameters to OFF before commencing the tuning cycle. The tuner will leave them off and will not calculate a value for them.

Typical automatic tuning cycle

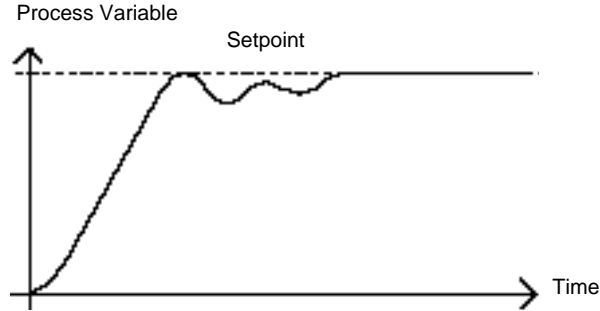

Calculation of the cutback values

Low cutback and *High cutback* are values that restrict the amount of overshoot, or undershoot, that occurs during large step changes in process variable (for example, under start-up conditions).

If either low cutback, or high cutback, is set to 'Auto' the values are fixed at three times the proportional band, and are not changed during automatic tuning.

Adaptive tune

Adaptive tuning is a background algorithm, which continuously monitors the error from setpoint and analyses the control response during process disturbances. If the algorithm recognises an oscillatory, or under-damped, response it recalculates the P_b , t_i and t_d values.

Adaptive tune is triggered whenever the error from setpoint exceeds a trigger level. This trigger level is set in the parameter 'drA.t', which is found in the Autotune list. The value is in display units. It is automatically set by the controller, but can also be manually re-adjusted.

Adaptive tune should be used with:

1. Processes whose characteristics change as a result of changes in the load, or setpoint.
2. Processes that cannot tolerate the oscillation induced by a One-shot tune.

Adaptive tune should not be used:

1. Where the process is subjected to regular external disturbances that could mislead the adaptive tuner.
2. On highly interactive multiloop applications. However, moderately interactive loops, such as multi-zone extruders, should not give a problem.

MANUAL TUNING

If for any reason automatic tuning gives unsatisfactory results, you can tune the controller manually. There are a number of standard methods for manual tuning. The one described here is the Ziegler-Nichols method.

With the process at its normal running process variable:

1. Set the Integral Time 'ti' and the Derivative Time 'td' to OFF.
2. Set High Cutback and Low Cutback, 'Hcb' and 'Lcb', to 'Auto'.
3. Ignore the fact that the process variable may not settle precisely at the setpoint.
4. If the process variable is stable, reduce the proportional band 'Pb' so that the process variable just starts to oscillate. If the process variable is already oscillating, increase the proportional band until it just stops oscillating. Allow enough time between each adjustment for the loop to stabilise. Make a note of the proportional band value 'B' and the period of oscillation 'T'.
5. Set the Pb, ti, td parameter values according to the calculations given in Table 4-2.

Type of control	Proportional band 'Pb'	Integral time 'ti'	Derivative time 'td'
Proportional only	2xB	OFF	OFF
P + I control	2.2xB	0.8xT	OFF
P + I + D control	1.7xB	0.5xT	0.12xT

Table 4-2 Tuning values

Setting the cutback values

The above procedure sets up the parameters for optimum steady state control. If unacceptable levels of overshoot or undershoot occur during start-up, or for large step changes in process variable, then manually set the cutback parameters 'LCB' and 'HCB'.

Proceed as follows:

1. Set the low and high cutback values to three proportional bandwidths (that is to say, $Lcb = Hcb = 3 \times Pb$).
2. Note the level of overshoot, or undershoot, that occurs for large atmosphere changes (see the diagrams below).

In example (a) increase 'LCB' by the overshoot value. In example (b) reduce 'LCB' by the undershoot value.

Example (a)

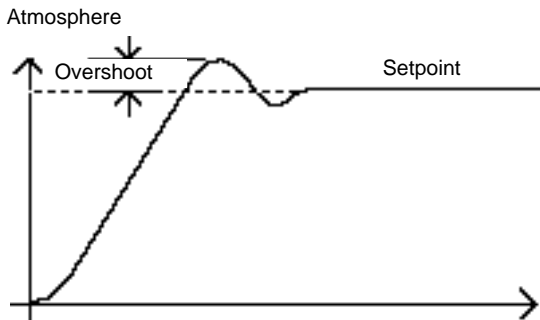

Example (b)

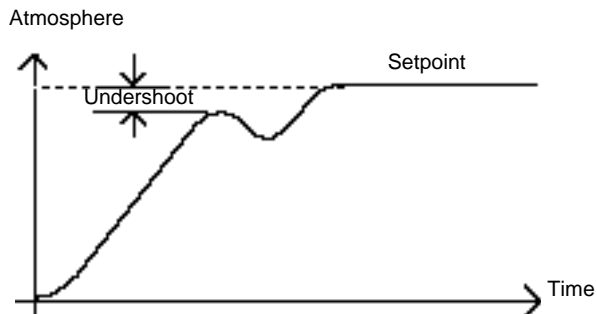

Where the atmosphere approaches setpoint from above, you can set 'HCB' in a similar manner.

Integral action and manual reset

In a full three-term controller (that is, a PID controller), the integral term 'ti' automatically removes steady state errors from the setpoint. If the controller is set up to work in two-term mode (that is, PD mode), the integral term will be set to 'OFF'. Under these conditions the measured value may not settle precisely at setpoint. When the integral term is set to 'OFF' the parameter *manual reset* (code 'rES') appears in the 'Pid LiSt' in 'FuLL' level. This parameter represents the value of the power output that will be delivered when the error is zero. You must set this value manually in order to remove the steady state error.

Automatic droop compensation (Adc)

The steady state error from the setpoint, which occurs when the integral term is set to 'OFF' is sometimes referred to as 'droop'. 'Adc' automatically calculates the manual reset value in order to remove this droop. To use this facility, you must first allow the process variable to stabilise. Then, in the autotune parameter list, you must set 'Adc' to 'on'. The controller will then calculate a new value for manual reset, and switch 'Adc' to 'OFF'.

'Adc' can be repeated as often as you require, but between each adjustment you must allow time for the process variable to stabilise.

motorized valve control

The AACC 2200 can be configured for motorised valve control as an alternative to the standard PID control algorithm. This algorithm is designed specifically for positioning motorised valves.

These are ordered pre-configured as Model numbers:

- 2200/VC motorised valve controllers
- 2200/VP motorised valve controllers with a single setpoint programmer
- 2200/V4 motorised valve controllers storing four setpoint programs.
- 2200/VM motorised valve controllers storing twenty setpoint programs.

Chapter 1 shows how to connect a motorised valve controller. The control is performed by delivering open, or close, pulses in response to the control demand signal.

The motorised valve algorithm can operate in one of three ways:

1. The so-called *boundless* mode, which does not require a position feedback potentiometer for control purposes; although one can be connected and used purely to display the valve's position.
2. Bounded, (*or position*), control mode, which requires a feedback potentiometer. This is closed-loop control determined by the valve's position.

The desired control mode is selected in the 'inst' list in configuration level.

The following parameter list will appear in the navigation diagram shown in Chapter 2, if your controller is configured for motorised valve control.

Name	Description	Values		
mtr	Motor list	Min	Max	Default
tm	Valve travel time in seconds. This is the time taken for the valve to travel from its fully closed position to its fully open position.	0.1	240.0	30.0
In.t	Valve inertia time in seconds. This is the time taken for the valve to stop moving after the output pulse is switched off.	OFF	20.0	OFF
bAc.t	Valve backlash time in seconds. This is the minimum on-time required to reverse the direction of the valve. i.e. the time to overcome the mechanical backlash.	OFF	20.0	OFF
mp.t	Output pulse minimum on-time, in seconds.	Auto	100.0	Auto
U.br	Valve sensor break strategy.	rEST, uP, dwn		dwn

COMMISSIONING THE MOTORISED VALVE CONTROLLER

The commissioning procedure is the same for both bounded and boundless control modes, except in bounded mode you must first calibrate the position feedback potentiometer, as described in the section below.

Proceed as follows:

1. Measure the time taken for the valve to be raised from its fully closed to its fully open position and enter this as the value in seconds into the 'tm' parameter.
2. Set all the other parameters to the default values shown in Table 4-3.

The controller can then be tuned using any of the automatic, or manual, tuning procedures described earlier in this chapter. As before, the tuning process, either automatic or manual, involves setting the values of the parameters in Table 4-1. The only difference with boundless control is that the derivative term 'td', although present, will have no effect.

Adjusting the minimum on-time 'mp.t'

The default value of 0.2 seconds is satisfactory for most processes. If, however, after tuning the process, the valve activity is excessively high, with constant oscillation between raise and lower pulses, the minimum on-time can be increased.

The minimum on-time determines how accurately the valve can be positioned and therefore the control accuracy. The shorter the time, the more precise the control.

However, if the time is set too short, process noise will cause an excessively busy valve.

Inertia and backlash settings

The default values are satisfactory for most processes, i.e. 'OFF'.

Inertia is the time taken for the valve to stop after the output pulse is turned off. If this causes a control problem, the inertia time needs to be determined and then entered into the parameter, 'In.t'. The inertia time is subtracted from the raise and lower output pulse times, so that the valve moves the correct distance for each pulse.

Backlash is the output pulse time required to reverse the direction of the valve, i.e. the time taken to overcome the mechanical backlash of the linkages. If the backlash is sufficient to cause a control problem, then the backlash time needs to be determined and then entered into the parameter, 'bac.t'.

The above two values are not part of the automatic tuning procedure and must be entered manually.



























CALIBRATING THE POSITION FEEDBACK POTENTIOMETER

Before proceeding with the feedback potentiometer calibration, you should ensure, in configuration level, that module position 2 (2a), or 3 (3a), has its 'id' indicating 'Pot.i', (meaning *Potentiometer Input*). Continue to scroll down the module

Marathon Monitors Inc.

configuration list. 'func' should be set to 'Vpos', 'VAL.L' must be set to '0' and 'VAL.H' to '100'.

Exit from configuration and you are now ready to calibrate the position feedback potentiometer. Proceed as follows.

1. In Operator level, press the AUTO/MAN button to put the controller in Manual mode.
2. Drive the valve to its fully open position using .
3. Press  until you get to 'ip-List'.
4. Press  to get to 'PCAL-OFF'.
5. Press  or  to turn 'PCAL' to 'on'.
6. Press  and the upper readout indicates 'Pot'.
7. Press  or  to get to 'Pot-3A.Hi'. (*Assuming that the Potentiometer Input Module is in module position 3.*)
8. Press  to go to 'GO-no'.
9. Press  or  to see 'GO-YES', which starts the calibration procedure.
10. Calibration is complete when the display returns to 'GO-no'.
11. Press  and  together to return directly to the Operator level.
12. The controller should still be in Manual mode.
13. Drive the valve to its fully closed position using .
14. Press  until you get to 'ip-List'.
15. Press  to get to 'PCAL-OFF'.
16. Press  or  to turn 'PCAL' to 'on'.
17. Press  and the upper readout indicates 'Pot'.
18. Press  or  to get to 'Pot-3A.Lo'.
19. Press  to go to 'GO-no'.
20. Press  or  to see 'GO-YES', which starts the calibration procedure.
21. Calibration is complete when the display returns to 'GO-no'.
22. Press  and  together to return directly to the Operator level.
23. Press the AUTO/MAN button to place the controller in AUTO and the calibration of the position feedback potentiometer is now complete.

Gain scheduling

Gain scheduling is the automatic transfer of control between one set of PID values and another. In the case of the AACC 2200 controllers, this is done at a presettable process value. It is used for the more difficult to control processes which exhibit large changes in their response time or sensitivity at, for example, high and low process variables, or when heating or cooling.

The AACC 2200 has two sets of PID values. You can select the active set from either a digital input, or from a parameter in the PID list, or you can transfer automatically in gain scheduling mode. The transfer is bumpless and will not disturb the process being controlled.

To use gain scheduling, follow the steps below:



Step1: Enable in configuration level

Gain scheduling must first be enabled in Configuration level. Goto the Inst Conf list, select the parameter Gsch, and set it to YES.

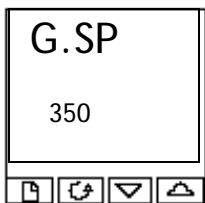

Step 2: Set the transfer point

Once gain scheduling has been enabled, the parameter G.SP will appear at the top of the Pid list in Full access level. This sets the value at which transfer occurs. PID1 will be active when the process value is below this setting and PID2 when the process value is above it. The best point of transfer depends on the characteristics of the process. Set a value between the control regions that exhibit the greatest change

Step 3: Tuning

You must now set up the two sets of PID values. The values can be manually set, or automatically tuned as described earlier in this chapter. When tuning automatically you must tune twice, once above the switching point G.SP and again below the switching point. When tuning, if the process value is below the transfer point G.SP the calculated values will automatically be inserted into PID1 set and if the process value is above G.SP, the calculated values will automatically be inserted into PID2 set.

CONFIGURATION

This chapter consists of six topics:

- SELECTING CONFIGURATION LEVEL
- LEAVING CONFIGURATION LEVEL
- SELECTING A CONFIGURATION PARAMETER
- CHANGING THE PASSWORDS
- NAVIGATION DIAGRAM
- CONFIGURATION PARAMETER TABLES.

In configuration level you set up the fundamental characteristics of the controller. These are:

- The type of control (e.g. reverse or direct acting)
- The Input type and range
- The Setpoint configuration
- The Alarms configuration
- The Programmer configuration
- The Digital input configuration
- The Alarm Relay configuration
- The Communications configuration
- The Modules 1, 2 & 3 configuration
- Calibration
- The Passwords.



WARNING

Configuration is protected by a password and should only be carried out by a qualified person, authorised to do so. Incorrect configuration could result in damage to the process being controlled and/or personal injury. It is the responsibility of the person commissioning the process to ensure that the configuration is correct.

Selecting configuration level

There are two alternative methods of selecting Configuration level:



- If you have already powered up, then follow the access instructions given in Chapter 3, *Access levels*.

Alternatively, press  and  together when powering up the controller. This will take you directly to the 'CONF' password display.



Password entry



When the 'CONF' display appears, you must enter the Configuration password (which is a number) in order to gain access to Configuration level.

Enter the password using the  or  buttons. The configuration password is set to '2' when the controller is shipped from the factory.

Once the correct password has been entered, there is a two second delay, after which the lower readout will change to 'PASS' indicating that access is now unlocked.

Note: A special case exists if the password has been set to '0'. In this situation, access is permanently unlocked and the lower readout will always show 'PASS'.



Press  to enter configuration.

(If an incorrect password has been entered and the controller is still 'locked' then pressing  at this point will take you to the 'Exit' display with 'no' in the lower readout. Simply press  to return to the 'CONF' display.)



You will obtain the first display of configuration.

LEAVING CONFIGURATION LEVEL

To leave the Configuration level and return to Operator level Press  until the 'Exit' display appears.

Alternatively, pressing  and  together will take you directly to the 'Exit' display





Use  or  to select 'YES'. After a two-second delay, the display will blank and revert to the Home display in Operator level.

SELECTING A CONFIGURATION PARAMETER



The configuration parameters are arranged in lists as shown in the navigation diagram in.

To step through the list headers, press the Page  button.

To step through the parameters within a particular list press the Scroll  button. When you reach the end of the list you will return to the list header.

You can return directly to the list header at any time by pressing the Page  button.

Parameter names

Each box in the navigation diagram shows the display for a particular parameter. The upper readout shows the name of the parameter and the lower readout its value. For a definition of each parameter, see the Configuration Parameter Tables at the end of this chapter. To change the value of a selected parameter, use the  and  buttons.

The navigation diagram shows all the lists headers and parameters that can, potentially, be present in the controller. In practice, those actually present will vary according to the particular configuration choices you make.

Changing the passwords

There are TWO passwords. These are stored in the Password configuration list and can be selected and changed in the same manner as any other configuration parameter.

The password names are: 'ACC.P' which protects access to Full level and Edit level
'cnF.P' which protects access to Configuration level.

Marathon Monitors Inc.

NAVIGATION DIAGRAM (PART A)

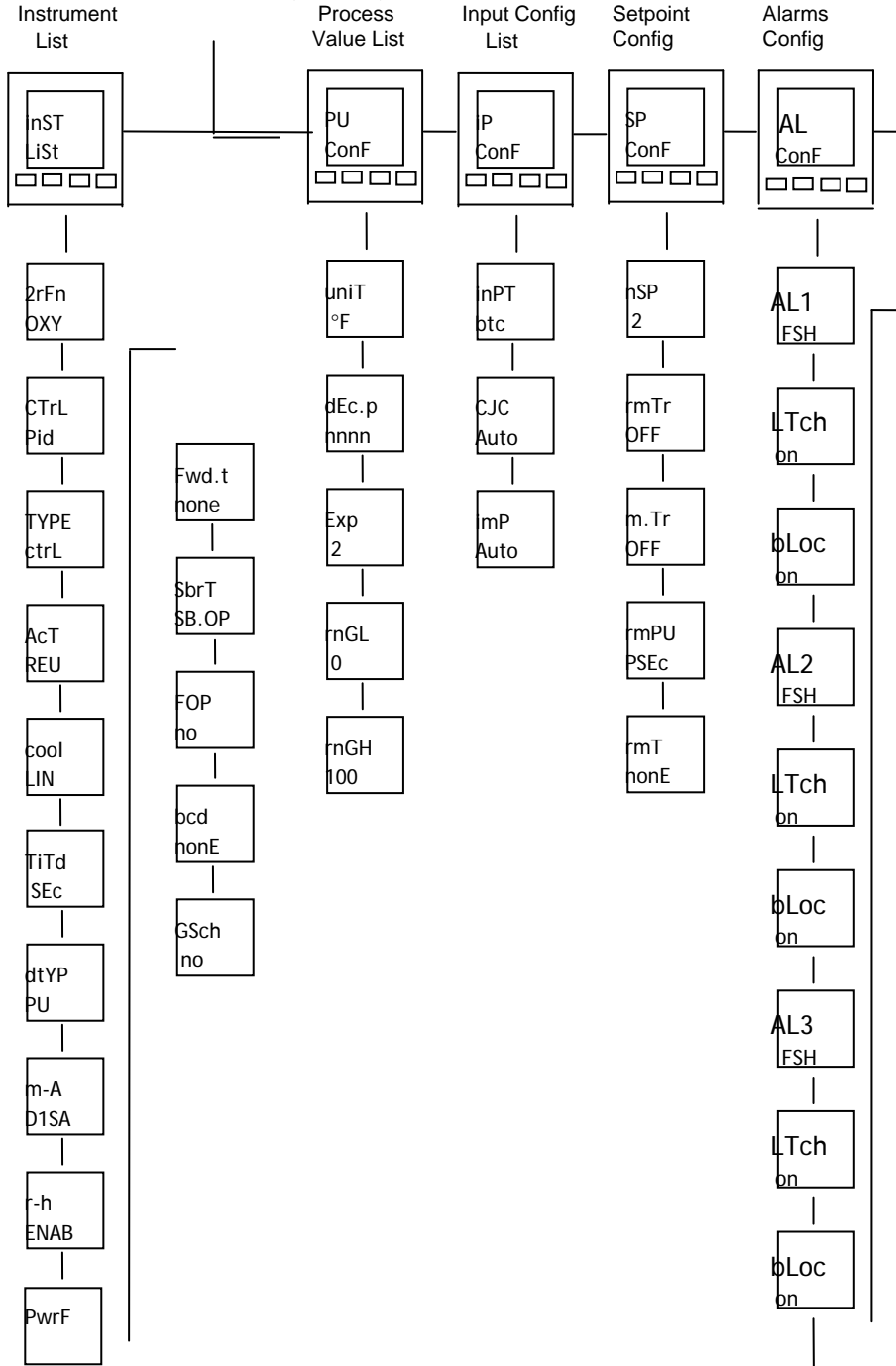

Marathon Monitors Inc.

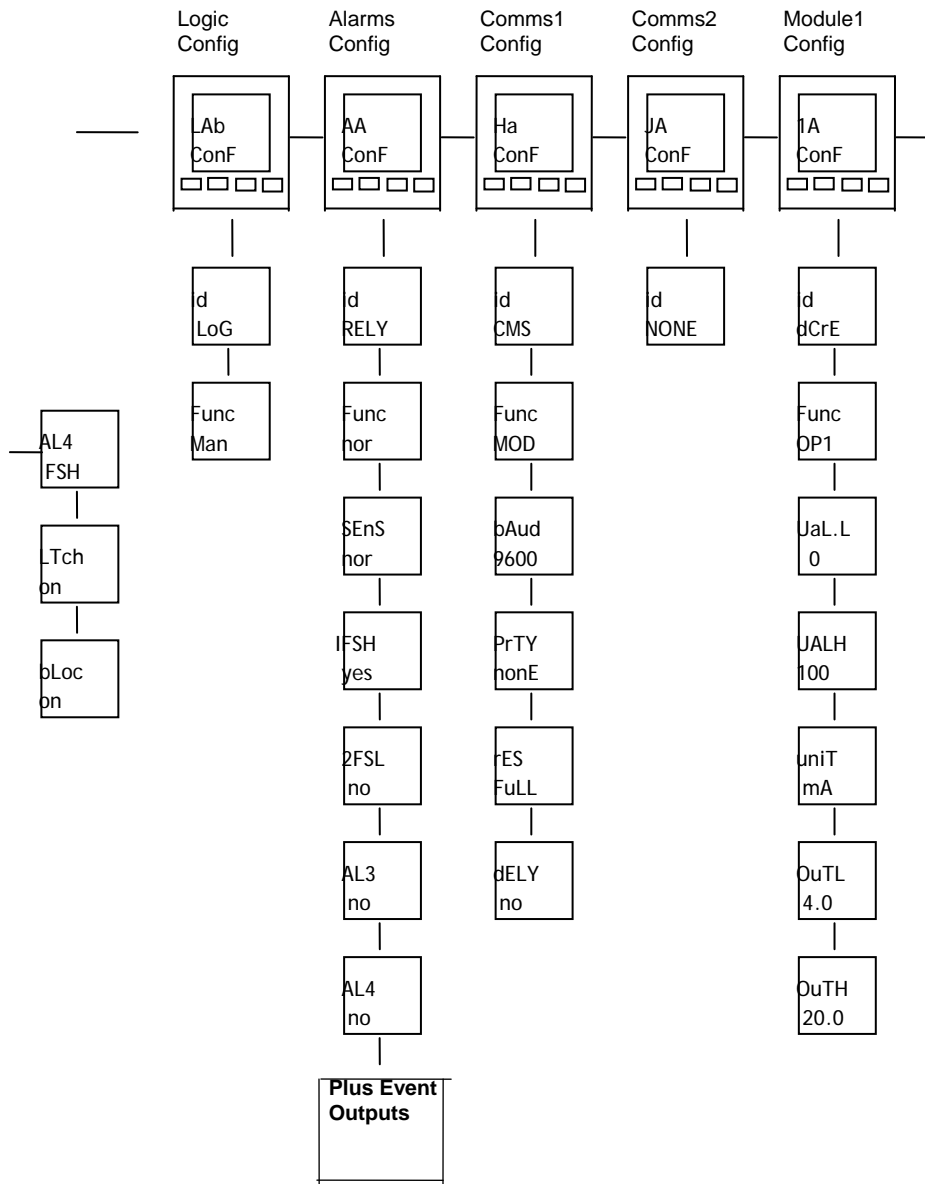

Marathon Monitors Inc.

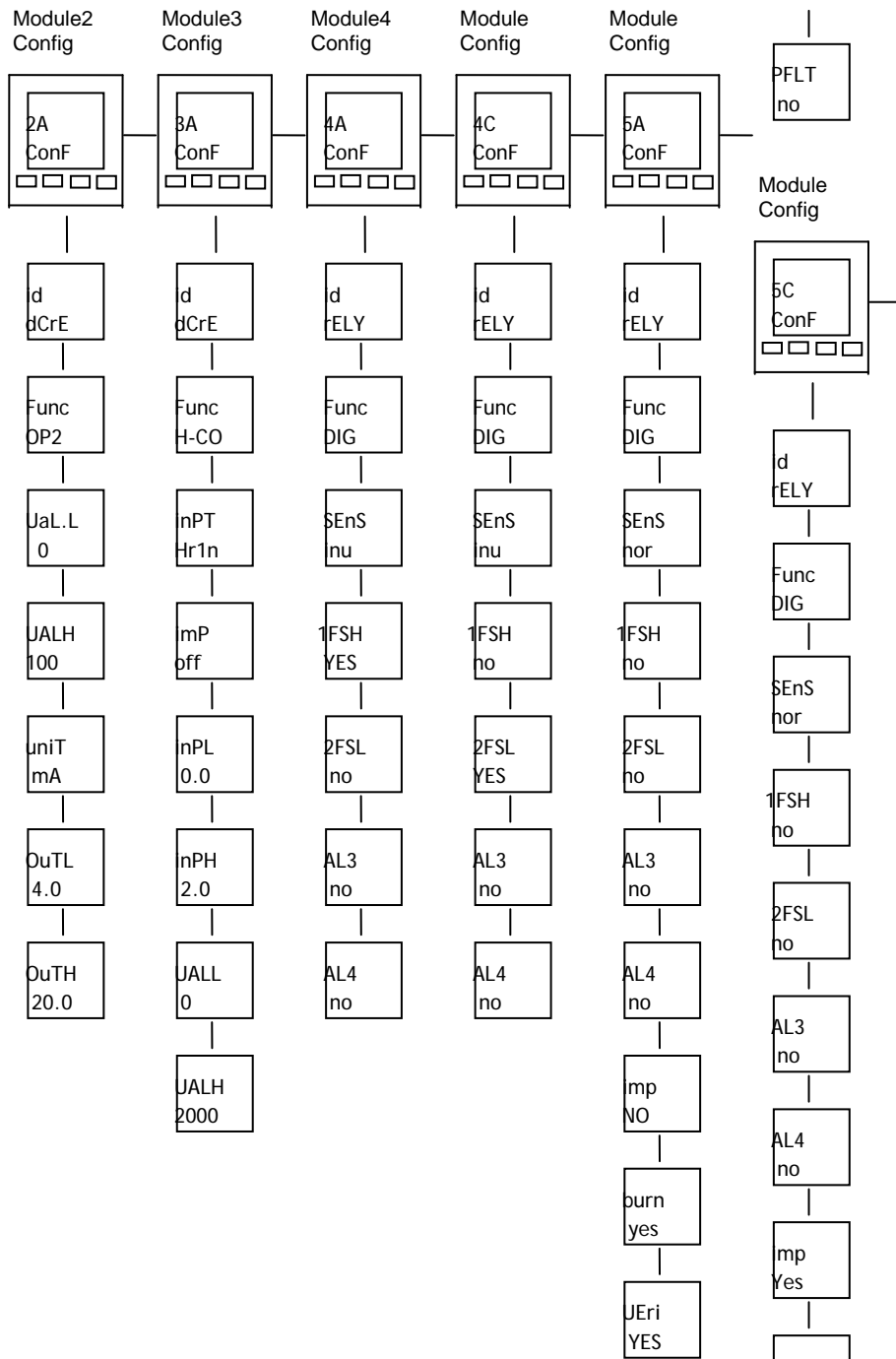

burn

NO

|

U
Eri
no

|

P
FLT
no

Marathon Monitors Inc.

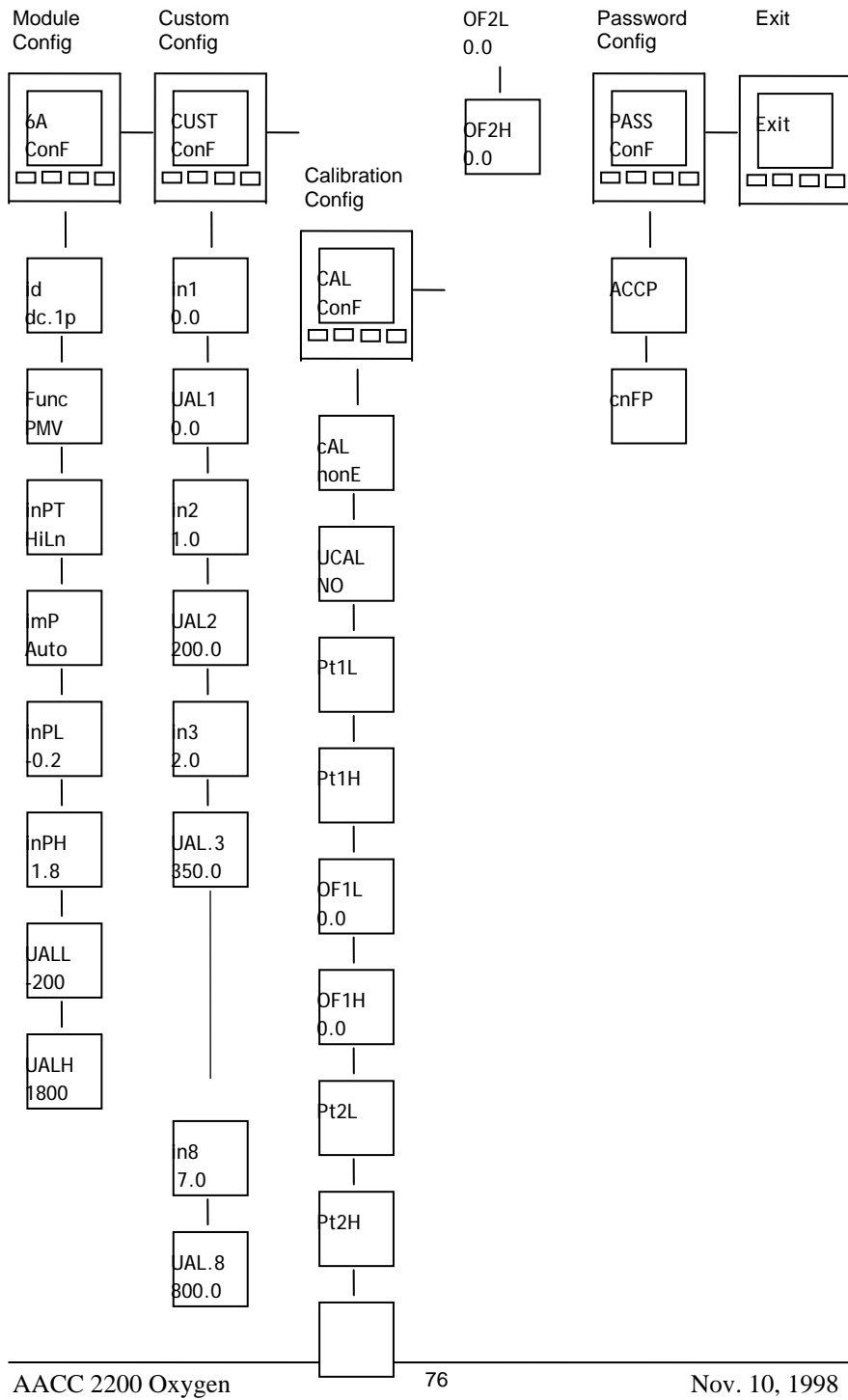

Marathon Monitors Inc.

CONFIGURATION PARAMETER TABLES

* = DEFAULT

Name	Description	Values	Meaning
inSt	Instrument configuration		
ZrFn	Instrument Function	Oxy	% Oxygen
Ctrl	Control type	*Pid On.OF VP VP b	PID control On/off control Boundless motorised valve control - <i>no feedback required</i> Bounded motorised valve control - <i>feedback required</i>
tYPE	Instrument USE	ctrl Mon	Controller Monitor
Act	Control action	*rEv dir	Reverse acting Direct acting
Cool	Type of cooling	*Lin oil H2O FAn ProP on.OF	Linear Oil (50mS minimum on-time) Water (non-linear) Fan (0.5S minimum on-time) Proportional only to error On/off cooling
ti.td	Integral & derivative time units	SEc min	Seconds, OFF to 9999 Minutes, OFF to 999.9
dtYP		PU/err	
m-A	Front panel Auto/Man button	*EnAb diSA	Enabled Disabled
r-h	Front panel Run/Hold button	*EnAb diSA	Enabled Disabled
PwrF	Power feedback	on *OFF	On Off
Fwd.t	Feed forward type	*none FEEd SP.FF PV.FF	None Normal feed forward Setpoint feed forward PV feed forward
Sbr.t	Sensor break output	*Sb.OP HoLd	Go to pre-set value Freeze output
FOP	Forced manual output	*no	Bumpless Auto/Manual

Marathon Monitors Inc.

		trac	transfer Returns to the Manual value that was set when last in Manual mode
		Step	Steps to forced output level. Value set in 'FOP' of 'op-List' in Operator Level
bcd	BCD input function	*none prog sp	Not used Select program number Select setpoint number
gsch	Gain schedule enable	no yes	Disabled Enabled

pV			
Process value config			
unit	Inststrument units	^o C * ^o F ^o k	Celsius Fahrenheit Kelvin
dec.p	Decimal places in the displayed value	none nnnn *nnn.n nn.nn	Display units blanked None One Two
Exp	Exponent	2 - 12 *2	Exponent of process value
rnL	Range low	*0.0	Low range limit. Also setpoint limit for alarms and programmers
rng.h	Range high	*100.0	High range limit. Also setpoint limit for alarms and programmers

Marathon Monitors Inc.

Name	Description	Values	Meaning
iP	Input configuration		
inPt	Input type	J.tc k.tc L.tc r.tc *b.tc n.tc t.tc S.tc PL 2 C.tc rtd mV voLt mA Sr V Sr A mV.C V.C mA.C	J thermocouple K thermocouple L thermocouple R thermocouple (Pt/Pt13%Rh) B thermocouple (Pt30%Rh/Pt6%Rh) N thermocouple T thermocouple S thermocouple (Pt/Pt10%Rh) PL 2 thermocouple Custom downloaded t/c (default = type C) 100Ω platinum resistance thermometer Linear millivolt Linear voltage Linear milliamps Square root volts Square root milliamps 8-point millivolt custom linearisation* 8-point Voltage custom linearisation* 8-point milliamp custom linearisation*
	* see "CUST" List.		
Name	Description	Values	Meaning
CJC	Cold Junction Compensation	*Auto 0°C 45°C 50°C OFF	Automatic internal compensation 0°C external reference 45°C external reference 50°C external reference No cold junction compensation
imp	Sensor Break Impedance	Off *Auto Hi Hi.Hi	Disabled (<i>only with linear inputs</i>) Factory set Impedance of input > 5KΩ Impedance of input >

Marathon Monitors Inc.

		15KΩ
Linear Input Scaling – The next 4 parameters only appear if a linear or sq rt input is chosen.		
inp.L		Input value low
inp.H		Input value high
VAL.L		Displayed reading low
VAL.H		Displayed reading high

Name	Description	Values	Meaning
SP	Setpoint configuration		
nSP	Number of setpoints	*2, 4, 16	Select number of setpoints available
rm.tr	Remote Tracking	*OFF trAc	Disable Local setpoint tracks remote setpoint
m.tr	Manual Track	*OFF trAc	Disable Local setpoint tracks PV when in manual
rmP.U	Setpoint rate limit units	*PSEc Pmin PHr	Per second Per minute Per hour
rmt	Remote setpoint configuration	*nonE SP Loc.t rmt.t	Disable Remote setpoint Remote setpoint + local trim Remote trim + local setpoint

Marathon Monitors Inc.

AL	Alarm configuration	Values
<i>The controller contains four 'soft' alarms, which are configured in this list. Once configured, they can be attached to a physical output as described in the alarm relay configuration list, 'AA Conf'.</i>		
AL1	Alarm 1 Type	see Table A
Ltch	Latching	no/YES/Evt/mAn*
bLoc	Blocking	no/YES
AL2	Alarm 2 Type	see Table A
Ltch	Latching	no/YES/Evt/mAn*
bLoc	Blocking	no/YES
AL3	Alarm 3 Type	see Table A
Ltch	Latching	no/YES/Evt/mAn*
bLoc	Blocking	no/YES
AL4	Alarm 4 Type	see Table A
Ltch	Latching	no/YES/Evt/mAn*
bLoc	Blocking (not if 'AL4' = 'rAt')	no/YES





Table A - Alarm types	
Value	Alarm type
OFF	No alarm
FSL	PV Full scale low
FSH	PV Full scale high
dEv	PV Deviation band
dHi	PV Deviation high
dLo	PV Deviation low
LCr	Load Current low
HCr	Load Current high
FL2	Input 2 Full Scale low
FH2	Input 2 Full Scale high
LOP	Working Output low
HOP	Working Output high
LSP	Working Setpoint low
HSP	Working Setpoint high
rAt	PV Rate of change <i>AL4 only</i>

Alarm Modes

'no' means that the alarm will be non-latching.

'YES' means that the alarm will be latched, with automatic resetting. Automatic resetting means that if a reset is actioned before the alarm has cleared, then it will automatically reset when it clears

Marathon Monitors Inc.

Name	Description	Values	Meaning
LA	Digital input 1 configuration		Action on contact closure
id	Identity	LoG.i	Logic input
Func	Function of input <i>The function is active when the input has a contact closure to the common terminal - LC</i>	*nonE mAn rmt SP.2 Pid.2 ti H tunE drA Ac.AL AccS Loc.b uP dwn ScrL PAGE bcd.1 bcd.2 bcd.3 bcd.4 bcd.5 bcd.6 Stby PV.SL IMP	No function Manual mode select Remote setpoint select Setpoint 2 select PID set 2 select Integral hold One-shot self-tune enable Adaptive tune enable Acknowledge alarms Select Full access level Keylock Simulate pressing of the  button Simulate pressing of the  button Simulate pressing of the  button Simulate pressing of the  button Least significant BCD digit 2nd BCD digit 3rd BCD digit 4th BCD digit 5th BCD digit Most significant BCD digit Standby - ALL control outputs turned OFF (alarm Outputs are not affected) PV Select: Closed = PV1 / Open = PV2 Initiate Impedance test
	<i>These BCD inputs are used to select either a program number or the setpoint number according to the setting of the parameter 'bcd' in the 'inSt' configuration list</i>		
Lb	Digital input 2 configuration		Action on contact closure
	As per Digital input 1 configuration		

Marathon Monitors Inc.

Name	Description	Values	Meaning
AA	Alarm relay configuration		
id	Identity	rELy	Relay output
Func	Function	*nonE dIG	No function Digital output
SEnS	Digital output sense	nor inv	Normal (<i>output energises when TRUE, e.g. program events</i>) Inverted (<i>output de-energises when TRUE, e.g. alarms</i>)
<i>The following digital events appear after 'SEnS'. Any one, or more, of the events can be combined on to the output by selecting 'YES' in the lower readout.</i>			
1 - - -	Alarm 1 active	YES / no	(- - -) = alarm type (e.g. FSL).
2 - - -	Alarm 2 active	YES / no	<i>If an alarm has not been configured</i>
3 - - -	Alarm 3 active	YES / no	<i>in 'AL Conf' list, then display will</i>
4 - - -	Alarm 4 active	YES / no	<i>differ:- e.g. Alarm 1 = 'AL 1'.</i>
mAn	Controller in manual mode	YES / no	
Sbr	Sensor break	YES / no	
SPAn	PV out of range	YES / no	
Lbr	Loop break	YES / no	
Ld.F	Load failure alarm	YES / no	
tunE	Tuning in progress	YES / no	
dc.F	Voltage output open circuit, or mA output open circuit	YES / no	
rmt.F	module connection open circuit	YES / no	
iP1.F	Input 1 Failure	YES / no	
IMP	Impedance test in progress	YES / no	
burn	Probe burn off in progress	YES / no	
VERi	Probe verification in progress	YES / no	
VFLT	Verification Fault	YES / no	
PFLT	Probe Fault	YES / no	
nw.AL	New Alarm has occurred	YES / no	
End	End of setpoint rate limit, or end of program	YES / no	
SYnc	Program Synchronisation active	YES / no	

Marathon Monitors Inc.

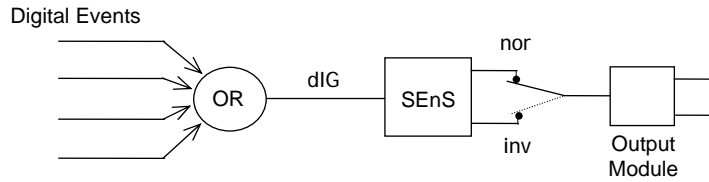

Figure 18 Combining several digital events on to one output

Name	Description	Values	Meaning
HA	Comms 1 module config		
id	Identity of the module installed	none	2-wire EIA-485

For 'id' = 'cms' (Digital communications) use this parameter table:			
Func	Function	mod *mAr	Modbus protocol Marathon Monitors protocol
bAud	Baud Rate	1200, 2400, 4800, *9600, 19.20(19,200)	
dELy	Delay - quiet period, required by some comms adaptors	*no YES	No delay Delay active - 10mS
PrtY	Comms Parity	nonE *EvEn Odd	No parity Even parity Odd parity
<i>The following parameters only appear if the function chosen is Modbus protocol.</i>			
rES	Comms Resolution	FuLL Int	Full resolution Integer resolution

Marathon Monitors Inc.

JA	module config		
NO configuration required			
Name	Description	Values	Meaning

1A/b/C ⁽¹⁾	Module 1 configuration		
id	Identity of module installed	nonE rELY dc.rE	Module not fitted Relay output DC retransmission (isolated)

For 'id' = 'rELY' use this parameter table:			
Func	Function <i>(Only Channels 1A and 1C can be Output Power)</i>	nonE dIG Op.1 Op.2 up dwn	Function disabled Digital output function Output power 1 Output power 2 Open motorised valve Close motorised valve
VAL.L			% PID demand signal giving minimum output – 'Out.L'
VAL.H			% PID demand signal giving maximum output – 'Out.H'
Out.L			Minimum average power
Out.H			Maximum average power
SEnS	Sense of output <i>(Only if 'Func' = 'dIG')</i>	nor inv	Normal <i>(output energises when TRUE, e.g program events)</i> Inverted <i>(output de-energises when TRUE, e.g. alarms)</i>
<p><i>Notes:</i></p> <ol style="list-style-type: none"> 1. When 'SEnS' appears, then further parameters are available. These are identical to those in the 'AA ConF' list on Page 6-12. 2. To invert a PID output, the Val. H can be set below the Val.L 			
Name	Description	Values	Meaning

Marathon Monitors Inc.

For 'id' = 'dc.rE' use this parameter table:			
Func	Function	nonE	Function disabled
		Op.1	Output Power 1
		Op.2	Output Power 2
		PV	Process Variable
		wSP	Work Setpoint
		Err	Error Signal
		OP	Output Power
		1p.1	Input 1
		1p.2	Input 2
		1p.3	Input 3
VAL.L	<div style="display: flex; align-items: center; justify-content: center;"> <div style="margin-right: 10px;">%PID, or Retransmission Value</div> </div>	% PID, or Retrans'n Value, giving minimum output	
VAL.H		% PID, or Retrans'n Value, giving maximum output	
unit		volts = Volts, mA = milliamps	
Out.L		Minimum electrical output	
Out.H		Maximum electrical output	

For 'id' = 'LoG.i' (i.e logic input) use the LA Conf' list on Page 6-11.

2A/b/C	Module 2 configuration		
As per module 1 configuration.			

Continued on next page

Marathon Monitors Inc.

3A/b/C	Module 3 configuration		
As per module 2 configuration, plus 'id' = 'dC.iP'			
For 'id' = 'dC.iP' use this parameter table. THIS INCLUDES THE SECOND PV FUNCTIONS			
Func	Function	nonE rSP Fwd.i rOP.h rOP.L Hi Lo Ftn *SEL trAn	Function disabled Remote Setpoint Feedforward input Remote OP power max. Remote OP power min. PV = The highest of iP.1, or iP.2 PV = The lowest of iP.1, or iP.2 Derived function, where PV = (f.1 x iP1) + (f.2 x iP2). 'F.1' and 'F.2' are scalars which are found in 'ip-List' of Operator Level Select ip.1, or ip.2 via Comms, front panel buttons, or a digital input Transition of control between ip.1 and ip.2. The transition region is set by the values of 'Lo.Ip' and 'Hi.Ip', which are found in 'ip-List' of Operator Level. PV = ip.1 below 'Lo.Ip' PV = ip.2 above 'Hi.Ip'
		H-CO	Hydrogen (Dewpoint) or Carbon Monoxide (Carbon) compensation
inpt	Input type	Refer to 'ip Conf' for all types, + the following: volt	
		HiIn	High Impedance (range = 0 to 2 volt)
CJC	Cold Junction Compensation	*OFF	No cold junction compensation
		Auto	Automatic internal compensation
		0°C	0°C external reference
		45°C	45°C external reference
		50°C	50°C external reference
imp	Sensor Break Impedance	*Off	Disabled (<i>only with linear inputs</i>)
		Auto	Factory set
		Hi	Impedance of input > 15KΩ
		Hi.Hi	Impedance of input > 30KΩ

Marathon Monitors Inc.

Linear Input Scaling – The next four parameters only appear if a linear input is chosen.

inP.L		Input value low	*0.0		
inP.H		Input value high	*5.0		
VAL.L		Displayed value low	*0		
VAL.H		Displayed value high	*100		
Name		Description		Values	Meaning

4 A /C	Module configuration		
As per module AA configuration			

5 A	Module configuration		
As per modult AA configuration			

Normal Setup for 5A is Func = dig, Sens = nor, and burn and vari = YES
 Normal Setup for 5C is Func = dig, Sens = nor, and Imp = YES

	Name	Description	Values	Meaning
--	-------------	--------------------	---------------	----------------

6A	Module configuration		
id	Identity of module DC input	rELy	DC input
Func	Function	pmv	Pin v probe mv input
inPT	Input type	HiIn	High Impedance (range = 0 to 2 volt)
inP.L		Input value low	*- 0.2
inP.H		Input value high	*1.8
VAL.L		Displayed value low	*- 200
VAL.H		Displayed value high	*1800

Marathon Monitors Inc.

Cust	8-point Custom Linearisation ⁽¹⁾	
in 1		Custom input 1
VAL.1		Linearisation Value representing in 1
in 8		Custom input 8
VAL.8		Linearisation Value representing in 8

Note:

1. Custom Linearisation is only available when '3a-Conf' or iP- ConF list has 'inpt' set to 'mV.C', or 'mA.C', or 'V.C'.
2. The values and inputs must be continuously increasing or decreasing

Marathon Monitors Inc.

Name	Description	Values	Meaning
CAL	Calibration		
<i>In this mode you can</i> <ol style="list-style-type: none"> 1. Calibrate the instrument using a mV source - rcAL or ref source cal. 2. Offset the calibration to account for errors in actual sensor measurement and a ref sensor - UCAL or user calibration 3. Return to factory set calibration - FACT or factory set calibration. 			
rcAL	Calibration point	nonE	No calibration
		PV	Calibrate main Process Value input.
		PV.2	Calibrate DC input, or PV 2.
		1A.Hi	Calibrate DC output high - Module 1
		1A.Lo	Calibrate DC output low - Module 1
		2A.Hi	Calibrate DC output high - Module 2
		2A.Lo	Calibrate DC output low - Module 2
		3A.Hi	Calibrate DC output high - Module 3
		3A.Lo	Calibrate DC output low - Module 3

Go to User calibration table-See also chapter 7

Go to input Calibration table

Go to DC Output Calibration table

INPUT CALIBRATION			
<i>For 'CAL' = 'PV', or 'PV.2', the following parameters apply.</i>			
PV	PV Calibration Value <ol style="list-style-type: none"> 1. Select calibration value 2. Apply specified input 3. Press to step to 'GO' <p style="text-align: right; margin-top: 10px;"><i>See Note below.</i></p>	ldLE	Idle
		mv.L	Select 0mV as the calibration point
		mv.H	Select 50mV as the calibration point
		V 0	Select 0V as the calibration point
		V 10	Select 10V as the calibration point
		CJC	Select 0°C CJC calibration point
		rtd	Select 400Ω as the calibration point
		HI 0	High impedance: 0V cal'n point
		HI 1.0	High impedance: 1.0 Volt cal'n point
		FACT	Restore factory calibration
GO	Start calibration	no	Waiting to calibrate PV point

Marathon Monitors Inc.

Select 'YES' with ▲ or ▼ Wait for calibration to complete.	YES	Start calibration
	buSy	Busy calibrating
	donE	PV input calibration completed
	FAIL	Calibration failed

Note. When a DC input module is installed for the first time, or there is a requirement to change one, then the microprocessor in the controller needs to read the factory calibration data stored in the module. Select 'FACT' as the calibration value. Step to 'GO' and start calibration.

DC Output Calibration			
<i>The following parameters apply to DC output modules ie for rcAL = 1A.Hi to 3A.Lo</i>			
cAL.H	Output Calibration High	0	0 = Factory set calibration. Trim value until output = 9V, or 18mA
cAL.L	Output Calibration Low	0	0 = Factory set calibration. Trim value until output = 1V, or 2mA

User calibration		
UCAL	User calibration enable	Yes/no
pt1.L	Low calibration point for Input 1	The factory calibration point at which the low point offset was performed.
pt1.H	High calibration point for Input 1	The factory calibration point at which the high point offset was performed.
OF1.L	Offset Low for Input 1	Calculated offset, in display units.
OF1.H	Offset High for Input 1	Calculated offset, in display units.
pt2.L	Low calibration point for Input 2	The factory calibration point at which the low point offset was performed.
pt2.H	High calibration point for Input 2	The factory calibration point at which the high point offset was performed.
OF2.L	Offset Low for Input 2	Calculated offset, in display units.
OF2.H	Offset High for Input 2	Calculated offset, in display units.

Name	Description	Values	Meaning
PASS Password configuration			
ACC.P	FuLL or Edit level password		
cnF.P	Configuration level password		
Exit Exit configuration			
Exit		no/YES	

User calibration

This chapter has five topics:

- WHAT IS THE PURPOSE OF USER CALIBRATION?
- USER CALIBRATION ENABLE
- OFFSET CALIBRATION
- TWO POINT CALIBRATION
- CALIBRATION POINTS AND CALIBRATION OFFSETS

To understand how to select and change parameters in this chapter you will need to have read *Operation*, *Access Levels* and *Configuration*.

WHAT IS THE PURPOSE OF USER CALIBRATION?

The basic calibration of the controller is highly stable and set for life. User calibration allows you to offset the 'permanent' factory calibration to either:

1. Calibrate the controller to the your reference standards.
2. Match the calibration of the controller to that of a particular transducer or sensor input.
3. Calibrate the controller to suit the characteristics of a particular installation.
4. Remove long term drift in the factory set calibration.

User calibration works by introducing a single point, or two-point, offset onto the factory set calibration.

User Calibration Enable

The User calibration facility must first be enabled in configuration level by setting the parameter 'UCAL' in the input conf list to 'YES'. This will make the User calibration parameters visible in Operator 'FULL' level.

Select configuration level as shown in *Configuration*.

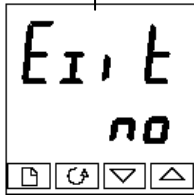
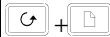



The Calibration Configuration List



Press  until you reach the 'CAL-Conf' list.

Press  until you reach 'UCAL'.



User Calibration Enable

Use  or  to select:

- YES: Calibration enable
- no: Calibration disabled

Press  and  together to go to the Exit display.

Exit configuration

Use  or  to select 'YES' to return to Operator level.

Offset calibration

Offset calibration is used to apply a single fixed offset over the full display range of the controller.

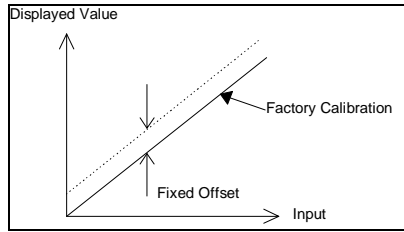

To calibrate, proceed as follows:

1. Connect the input of the controller to the source device to which you wish to calibrate.
2. Set the source to the desired calibration value.
3. The controller will display the current measurement of the value.
4. If the displayed value is correct, then the controller is correctly calibrated and no further action is necessary. If it is incorrect, then follow the steps shown below.

Select 'FULL' access level, as described in Chapter 3

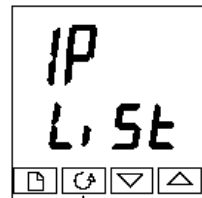

Input list header

Press  until you reach the input list header.



Press  until you reach the 'CAL' display.



Calibration type



- FAcT: Factory Calibration
- USEr: User Calibration

Use  or  to select 'FAcT'.

Selecting 'FAcT' reinstates the factory calibration and allows the application of a single fixed offset.

Press  continued on the next page

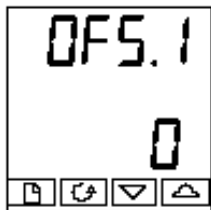

Set Offset 1

Use  or  to set the offset value of Process Value 1 (PV1).



The offset value is in display units *Press* 

Set Offset 2

Use  or  to set the offset value of Process Value 2 (PV2), if configured.

The offset value is in display units.

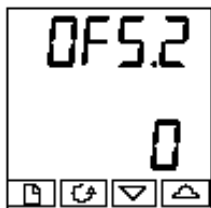

Press 

The table below shows the parameters which appear after 'OFS.2'. These are all read only values and are for information. *Press*  to step through them.

mV.1	IP1 measured value (at terminals)
mV.2	IP2 measured value (at terminals), if DC input in Module 3 position
CJC.1	IP1 Cold Junction Compensation
CJC.2	IP2 Cold Junction Compensation
Li.1	IP1 Linearised Value
Li.2	IP2 Linearised Value
PV.SL	Shows the currently selected input

See table on the right for additional parameters.

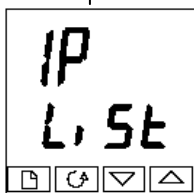

If you do not want to look at these parameters, then press



and this returns you to the 'IP-LiSt' header.

To protect the calibration against unauthorised adjustment, return to Operator level and make sure that the calibration parameters are hidden. Parameters are hidden using the 'Edit' facility described in Chapter 3, *Access Levels*

Two-point calibration

The previous section described how to apply a offset, or trim, calibration, which applies a fixed offset over the full display range of the controller. A two-point calibration is used to calibrate the controller at two points and applies a straight line between them. Any readings above, or below, the two calibration points will be an extension of this straight line. For this reason it is best to calibrate with the two points as far apart as possible.

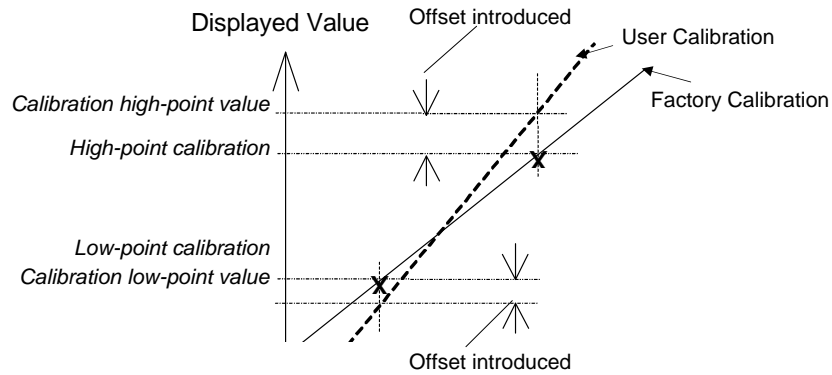

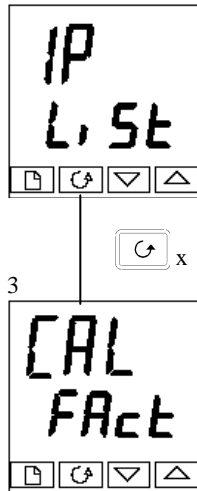

To calibrate Proceed as follows:

1. Decide upon the low and high points at which you wish to calibrate.
2. Perform a two point calibration in the manner described below



Input list header

Press  until you reach the input list header, 'ip List'.

Press  until you reach the 'CAL' display.

Calibration type

- FACT: Factory Calibration
- USER: User Calibration

Use  or  to select 'USER'.

Selecting 'USER' enables two-point calibration.

[If two-point calibration is unsatisfactory, select 'FACT' to return to the factory set calibration.]

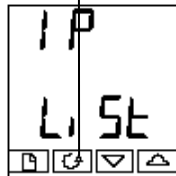

Press 



Select Low-point Calibration

This is the Calibration Status display. This display shows that no input is selected for calibration.



- nonE: No selection
- ip1.L: Input 1 (PV1) calibration low-point selected
- ip1.H: Input 1 (PV1) calibration high-point selected
- ip2.L: Input 2 (PV2) calibration low-point selected
- ip2.H: Input 2 (PV2) calibration high-point selected

Use / to select the parameter for the Low Calibration point of Input 1, 'ip1.L'.

Press 

Adjust low-point calibration

This is the display for adjusting the Low Calibration point of Input 1. The lower readout is a live reading of the process value, which changes as the input changes.

Make sure that the calibration source is connected to the terminals of Input 1, switched on and feeding a signal to the controller. It should be set to the desired low-point calibration value. If the lower readout does not show this value, then use / to adjust the reading to the required value.

Press  to return to the 'ip-List' header.

To perform the High-point Calibration, repeat the above procedure, selecting 'ip1.H' in the 'CAL.S' display for adjustment.

Press  three times.

Calibration type

'USER' was selected for the Low-point Calibration, and has remained selected.

Press 

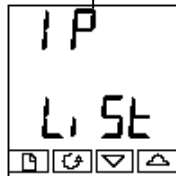
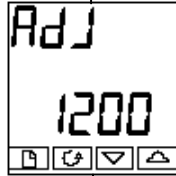

Select High-point Calibration

This is the Calibration Status display, again.

Use to select the parameter for the High-point Calibration of Input 1, 'ip1.H'.

Press

Adjust High-point Calibration

This is the display for adjusting the High Calibration point of Input 1. The lower readout is a live reading of the process value, which changes as the input changes.

Feed the desired high-point calibration signal to the controller, from the calibration source. If the lower readout does not show this value, then use to adjust the reading to the required value.

Press to return to the 'ip-List' header.

To protect the calibration against unauthorised adjustment return to Operator level and make sure that the calibration parameters are hidden. Parameters are hidden using the 'Edit' facility described in Chapter 3.

To perform a User Calibration on Input 2, proceed as with Input 1 above, except that when 'CAL.S-nonE' appears, press until 'CAL.S-ip2.L' is obtained, then proceed as with Input 1. Repeat the procedure for 'ip2.H'

Calibration points and Calibration offsets

If you wish to see the points at which the User calibration was performed and the value of the offsets introduced, then these are shown in Configuration, in 'CAL-Conf'.

The parameters are:

Name	Parameter description	Meaning
pt1.L	Low calibration point for Input 1	The factory calibration point at which the low point offset was performed.
pt1.H	High calibration point for Input 1	The factory calibration point at which the high point offset was performed.
OF1.L	Offset Low for Input 1	Calculated offset, in display units.
OF1.H	Offset High for Input 1	Calculated offset, in display units.
pt2.L	Low calibration point for Input 2	The factory calibration point at which the low point offset was performed.
pt2.H	High calibration point for Input 2	The factory calibration point at which the high point offset was performed.
OF2.L	Offset Low for Input 2	Calculated offset, in display units.
OF2.H	Offset High for Input 2	Calculated offset, in display units.

Note: The value of each of the parameters in the above table may also be altered by using the ▲/▼ buttons.

INDEX

Access Levels	51
Adaptive Tune	41, 58, 78
Adjust Low-Point Calibration.....	93
Adjusting The Minimum On-Time	63
Alarm Types	40, 49, 77
Alarms	24, 27, 49, 66, 69, 70
Automatic Mode	24, 28, 29
Backlash	63
Blocking	49, 77
CALIBRATING THE POSITION FEEDBACK POTENTIOMETER	63
Changing The Passwords.....	68
COMMISSIONING THE MOTORISED VALVE CONTROLLER	63
Comms.....	37, 44, 70, 80, 83
Communication	10, 21, 31, 44, 66
Configuration Level.....	50, 51, 52, 53, 65, 67, 68, 87
Configuration Password.....	45, 53, 67
Diagnostic Alarms	40, 49, 50
Gain Scheduling	65
Home	27, 29, 30, 31, 35, 39, 44, 49, 52, 54, 55, 57, 68
Inertia.....	63
Inertia And Backlash Settings.....	63
Input List Header	92
Installation	14
Latching	49, 77
Level Selection	53
Manual Mode.....	24, 28, 39, 64, 74, 78
Navigation	69
Non-Latching.....	49
Offset Calibration	90
Parameters	31
Password Entry	52, 67
Process Alarms	49
Promoting A Parameter	55
SAFETY And EMC INFORMATION	6
Select Low-Point Calibration.....	93
Selecting A Configuration Parameter	68
Setpoint.....	19, 26, 27, 29, 30, 31, 36, 39, 40, 43, 66, 69, 73, 76, 77, 78, 83
Snubbers	18
Technical Specification	10
Tuning.....	56, 57, 59
Two-Point Calibration	92
User Calibration.....	88