

10PULSE Manual

Version 1.05

Copyright(C) 2004
Marathon Monitors, Inc.

This manual has a part number #F200007

COPYRIGHT^(C)

No part of this publication may be reproduced, transmitted, transcribed, stored in a retrieval system, or translated into any language or computer language, in any form or by any means, electronic, mechanical, magnetic, optical, chemical, manual, or otherwise, without prior written permission of Marathon Monitors, Inc., 8904 Beckett Rd., West Chester, OH 45069 USA. 800-547-1055, www.group-upc.com.

Revision date: 05-20-04

This revision for format change only.

This manual covers revisions 1.03 and upwards.

Revision number 1.05

DISCLAIMER:

The 10PULSE is a Process Controller to be used by the industrial operator under his/her direction. Marathon Monitors, Inc. is not responsible or liable for any product, process, damage or injury incurred while using the 10PULSE. Marathon Monitors, Inc. makes no representations or warranties with respect to the contents hereof and specifically disclaims any implied warranties or merchantability or fitness for any particular purpose.

Marathon Monitors, Inc.

Table of Contents

Introduction.....	3
Set up procedures.....	4
Installation preparations.....	4
Panel mounting/removal.....	4
Proximity sensor and other signal wires.....	5
Control devices.....	5
Chart recorders.....	6
Computer interface.....	7
Alarms.....	7
Ac power.....	9
Control contacts.....	9
Signal input.....	9
Analog output.....	10
Communications.....	10
Removing the 10pulse from the case.....	10
Changing 110/220v input power jumpers.....	12
Pulse sensor jumper installation.....	13
Sensor jumper table.....	14
Specifications.....	15
Front panel.....	17
Parameter entry modes.....	20
Setpt parameter mode.....	23
Setup parameter mode.....	23
Input scaling.....	29
How the input scaling works.....	31
Calibration.....	33
Analog output calibration.....	35
Host communications.....	37
Hardware description.....	37
Protocol format.....	37
Command set.....	39

INTRODUCTION

The MMI 10PULSE Controller represents the state of the art in microprocessor-based process control technology for pulse input applications.

The following features have been included to allow use of the instrument in a wide variety of applications:

- Fully site-configurable for single loop control with a variety of control modes
- a fully isolated analog input designed for use with high frequency (NAMUR standard) proximity switches.
- two (2) configurable control output triacs for combined use in single control loop mode
- a fully isolated analog output configurable for voltage or current output
- two (2) configurable alarm triacs, assignable as process alarms or deviation alarms
- an RS 485 communications port for data transfer to and from a host.

This manual provides all of the information required to install, set-up, operate, use the communication port and troubleshoot the MMI 10PULSE.

SET UP PROCEDURES

Installation Preparations

The 10PULSE instrument is designed for up to 1/8" thick panel mounting in a DIN standard opening of 3.62" square (adapter panels available by special order). Required rear clearance is 10.5" to allow for wiring.

As with all solid state equipment, the controller should be located away from excessive heat, humidity, and vibration (Refer to Section 1.5 for specifications). Since the unit uses red LED display devices, it should also be located in a place that will reduce direct sunlight interference with the display's visibility. The instrument requires 120/240 VAC (jumper selectable on the power board inside the 10PULSE) at 50/60 Hz and should not be on the same circuit with other noise-producing equipment such as induction machines, large electrical motors, etc. Signal wiring must be run separate from control wiring.

Panel Mounting/Removal

To mount the 10PULSE in a control panel, a hole must be cut 3.62" square in the necessary location on the panel. The following procedure should be followed to mount the 10PULSE in the panel.

- 1) INSERT unit into previously cut out 3.62" square hole in panel.
- 2) While supporting unit, insert one clamping bracket into the groove on the side of unit, and then install the 6-32 set screw.
- 3) Repeat step 2 for the opposite side of the unit.

Marathon Monitors, Inc.

- 4) With a HEX KEY wrench, alternately tighten the screw on either side of instrument to a torque of six in.-lbs. Insure rigidity of mounting.

To remove the instrument from the panel, reverse the above procedures.

Proximity sensor and Other Signal Wires

The wiring used to connect the signal wires to the instrument should be run in conduit, separate from any AC lines in the area. This provides noise immunity and physical protection. Twisted pair shielded wire should be used for the sensor with the shield grounded at the sensor end only. Be certain that the NAMUR standard proximity sensor usually shipped with the instrument is the correct one for the setting. Many "failure" complaints have been corrected with the installation of the correct sensing device. Contact your Marathon Representative for other options if the sensor is not correct.

Control Devices

The 10PULSE provides Proportional control as well as simple ON/OFF through its two contact closure CONTROL OUTPUTS and its ANALOG OUTPUT. This allows control through Proportional control methods or through simple ON/OFF devices.

Three types of Proportional control are:

- 1) Voltage or Current output proportioning: Analog output (voltage or current) is varied to control the process.
- 2) Position-Proportioning: Refers to the adjustment of a variable positioning device such as a positioning motor using the analog control output. (Note: Slidewire feedback is not supported in the 10PULSE.)

Marathon Monitors, Inc.

3) Time-Proportioning: Refers to the modulation of the duty cycle. That is, the changing ratio of On Time versus Off Time in systems that use such devices as heating elements and On/Off valves.

A typical application for the Proportioning method is:

ANALOG OUTPUT CONTROL: set the Control Modes for time proportioning. This provides a 0 to 5 V dc or 4 to 20 mA output which is selectable at the ANALOG output terminals (TBB-4 Through TBB-6 see the analog output section for details). The output control is based on 0 to 100% of the output device's control range. For example: 50% control would equal 2.5 V dc out where 5V dc is maximum output of the drive. this can be used with servo drives which require a Voltage or current command signal for controlling RPM output or speed control.

Please remember that this is just an example of 10 Pulse application. Call your MMI representative or our service department with questions regarding your application.

Simple ON / OFF control:

With Simple ON/OFF control: Set the Control Mode for ON/OFF control. This provides contact closure at CONTROL OUTPUT #1 to control on off action. This mode is not recommended for RPM or speed control

Chart Recorders

If a chart recorder is to be used, it should have input specifications within the following ranges, for maximum accuracy:

0 to 5VDC

4 to 20 mA

corresponding to a FRONT PANEL display as selected by the Analog Output Offset and Range. The ideal location of the recorder is adjacent to the instrument but it may be located remotely if the connecting wires are properly shielded. Long wiring runs from the chart recorder outputs may require resistive termination (2K ohms or

Marathon Monitors, Inc.

so) at the remote end to decrease the effects of shop noise. For best results, the chart recorder input(s) should be isolated from ground.

Computer Interface

If advantage of the 10PULSE's RS-485 digital communications capabilities is to be taken, refer to section 4.0 "Communications" for more details.

Alarms

Two user-programmable Triac alarm contacts are available in either process or deviation modes.

Marathon Monitors, Inc.

Electrical Connections

Connections to the unit are made via two terminal blocks, located on the REAR PANEL, labeled TBA and TBB. (Position 1 is located at the top and position 10(TBA) or 8(TBB) is located at the bottom of the terminal strip). AC power, control, and alarm connections are made on TBA. All communications and analog I/O signals are located on TBB. Refer to Figure 1.1 for a complete layout of the 10PULSE REAR PANEL connections.

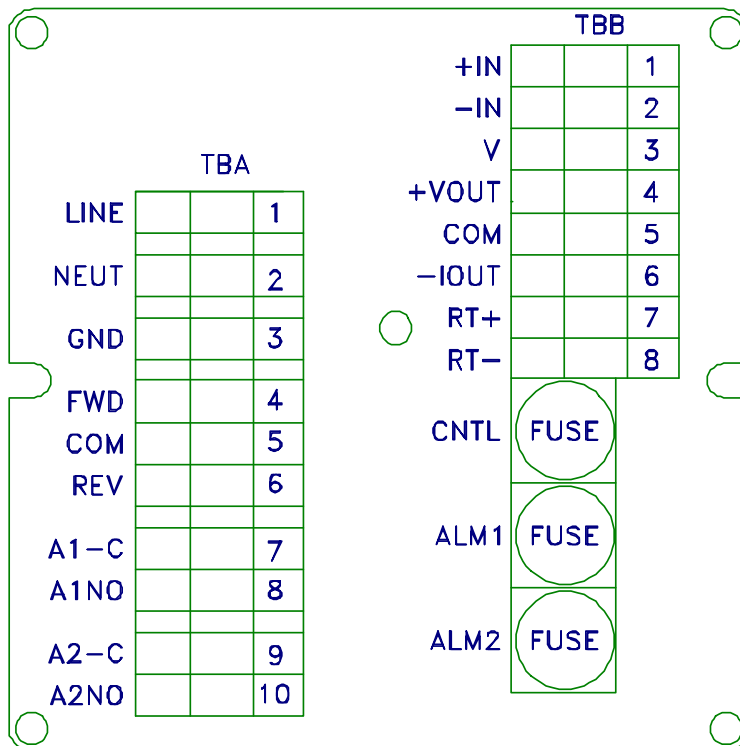

Figure 1.1: 10Pulse Rear Panel

AC Power

The 10PULSE requires 120/240 VAC @ 1 AMP, connected as follows:

120/240 VAC	-	TBA-1
NEUTRAL	-	TBA-2
EARTH GROUND	-	TBA-3

Control Contacts

Eight control contacts are located on TBA and TBB as follows:

CNTRL #1	N.O.	-	TBA-4
	COM.	-	TBA-5
CNTRL #2	N.O.	-	TBA-6
ALARM #1	N.O.	-	TBA-8
	COM.	-	TBA-7
ALARM #2	N.O.	-	TBA-10
	COM.	-	TBA-9

Signal Input

Note: Input specifications for sensor inputs.

NAMUR - 5 to 25vdc / 1ma to 2.2 ma.

MAGNETIC - Minimum 50mv peak to peak 2 volts.

3 WIRE - Max 15ma.

The 10PULSE allows for the input to be determined by a "daughter board" located on the main input board inside the unit.

NAMUR or MAGNETIC SENSORS

SIGNAL + - TBB-1

SIGNAL - - TBB-2

TBB-3

Marathon Monitors, Inc.

3 WIRE CMOS SWITCHES

SUPPLY - TBB-1

SWITCH - TBB-2

COMMON - TBB-3

Analog Output

An isolated analog output is provided on TBB that can be selected as current or voltage output by wiring to the proper terminals

For Voltage + - TBB-4
OUTPUT - - TBB-5

For Current + - TBB-5
OUTPUT - - TBB-6

Note:

When switching from voltage to current, or current to voltage, the Analog output must be recalibrated

Communications

Half duplex RS 485 communications.

HOST PORT:

RT+-TBB-7

RT--TBB-8

Removing the 10PULSE from the Case

This section describes how to remove the instrument from the case, if required.

WARNING

Marathon Monitors, Inc.

110 VAC or 220 VAC are present on the rear panel of the 10PULSE. Ensure that instrument power, external control and alarm voltages are secured to the instrument.

- 1) Ensure that all power sources connected to the 10PULSE are secured.
- 2) Disconnect and tag all connections at the rear panel of the 10PULSE.
- 3) Remove the 6-32 Phillips screw near the center of the rear panel of the 10PULSE.
- 4) Push lightly on the terminal blocks at the rear panel until the outer edge of the terminal blocks meets the face of the rear panel.

ATTENTION

Electrostatic sensitive devices are exposed when the instrument is removed from the case. Observe ElectroStatic Discharge handling procedures.

- 5) At the front of the panel continue to pull the instrument out of the case until the rear terminals clear the front bezel of the case.
- 6) If the instrument is to be shipped without the case, place it into an ESD shielding bag before adding any additional packing materials.

Changing 110/220V Input Power Jumpers

The 10PULSE is typically configured to accept 110 VAC for use in the Americas and 220 VAC for use in Europe and Asia.

This section describes how to verify and change the power configuration of the 10PULSE if it is required.

Remove the 10PULSE from the case following the removal procedure (Section 1.3).

ATTENTION

Electrostatic sensitive devices are exposed when the instrument is removed from the case. Observe ElectroStatic Discharge handling procedures.

To verify the input power setting on the 10pulse, locate the power selection jumpers on the 10PULSE power board. The power board can be identified by the ten position terminal block and two transformers mounted on the board. The power selection jumpers are at upper rear part of the board near fuse F4.

For 110 VAC operation the wire jumpers should be soldered to the four pads on the power board as shown in the following figure.

o-----o
o-----o

Jumper Configuration for 110 VAC Operation

For 220 VAC operation a wire jumper should be soldered to the forward two pads on the power board as shown in the following figure.

o o

I

Jumper Configuration for 220 VAC Operation

It is necessary to desolder/solder these jumpers on the 10PULSE power board to change the power input configuration. Ensure that proper ESD handling procedures are followed while working on the exposed circuit boards of the 10PULSE. It should not be necessary to remove the power board from the mounting brackets connecting it to the main board and display board.

When changing from 110 VAC to 220 VAC ensure that both jumpers are removed before soldering the vertical jumper. Inspect any modification to verify that no solder bridges exist between pads before installing the instrument and applying power. Insert the instrument into the case and reconnect the wires that were attached to the rear panel if applicable.

Pulse Sensor Jumper Installation

The Analog Input Daughter Board jumpers for selection of pulse input information is located on the Main board. Using the assembly drawing below locate jumper areas Jx1 and Jx2. Install the input jumper according to the chart below for the kind of pulse sensor used in the application.

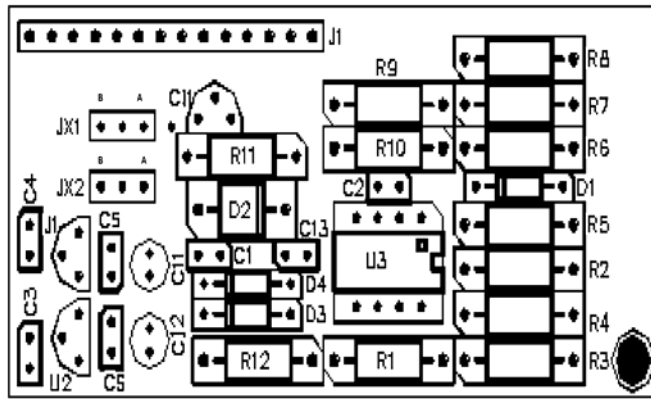

Analog Input Daughter Board Drawing

SENSOR JUMPER TABLE

Pulse Sensor	Jx1	Jx2
NAMUR	A	A
MAGNET	OUT	B
3 WIRE	B	A

Specifications

Alarm Outputs Two user selectable Triac outputs for process alarms. 1 A, 125/240 maximum (fused at 1 A)

Ambient Temperature 0 to 130°F

Analog Output 0 to 5 volts or 4 to 20 mA for ZERO to full SPAN. Programmable to other ranges, but with a slight loss of accuracy.

Control Outputs Two Triac outputs selectable for Time-Proportioning or Position-Proportioning. 1 A, **125/240** maximum (fused at 1 A)

Serial Interface: Host RS-485, 1200/4800 BAUD, Half Duplex, Even Parity.

Dimensions 3.78"W X 3.78"H X 9.0"L

Humidity 0 to 85% non-condensing

Input High frequency proximity sensing switch (Namur Standard)

Input Pulse Rate Range SLOW = 2 pulses per minute to 150 pulses per minute FAST = 2 pulses per second to 6000 pulses per second

Line Voltage 95 to 125 VAC, 50/60 Hz 190 to 250 VAC, 50/60 Hz

Marathon Monitors, Inc.

Panel Cutout Requirements 3.62'H X 3.62"W, (1/4 DIN)

ID Constants	Proportional Band	1 to 999% of Range
	Reset	0 to 99.99 RPM
	Rate	0 to 9.99 minutes
	Cycle Time	0 to 200 seconds
	Load Line	0 to 100%

Power Requirements 18 VA maximum

Setpoint 0 TO 9999

Signal Display Range 0.001 to 9999

Weight Approximately 4 pounds

Front Panel

The 10PULSE front panel consists of two groups of four seven segment LED displays, eight LED indicators, and eight membrane keyboard keys. The upper seven segment LED display shows the process value in normal operation and is referred to as the Process window. When entering parameters, this display will show a message identifying the parameter being entered. The lower display in normal operation will show the process setpoint when in auto or remote and the control percent output when in manual and is referred to as the Set window. When entering parameters, this display will show the value of the parameter being entered. This display will temporarily show other data dependent on certain keys being held down as described in the keyboard section.

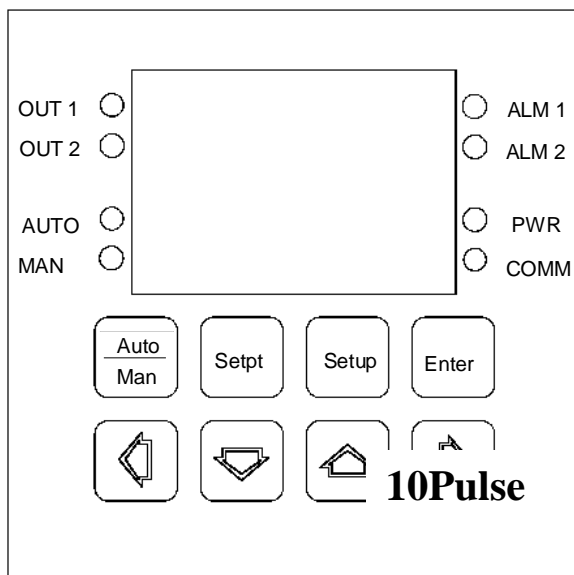

Figure 2 -1: 10PULSE Front Panel

Marathon Monitors, Inc.

The eight LED indicators provide information on the operation of the 10PULSE as follows:

LED on	Function
Pwr	shows that the internal power supply is working properly
Comm	will flash whenever the 10PULSE is transmitting over the RS-485 port
Auto	indicates that the 10PULSE is in automatic control mode
Out 1 and Out 2	indicate the state of the control output triacs. If either of the LEDs is illuminated, then the respective output triac is ON
Alm 1 and Alm 2	indicate the state of the two alarm triacs. If either of the LEDs is illuminated, then the respective output triac is ON

The functions of the eight membrane keys may change when the 10PULSE is placed into different modes. This section will describe the keys if activated from the normal mode of operation. The sections on the various modes will describe how the keys are used in that mode.

Marathon Monitors, Inc.

<u>KEY</u>	<u>DESCRIPTION</u>
Auto Man	This key selects the control mode of the 10PULSE. Each press of this key cycles the control mode from Manual to Auto to Manual etc.
setpt	Pressing this key places the 10Pulse into parameter entry mode for the local setpoint, when the security is off.
setup	Pressing this key places the 10Ppulse into parameter entry mode for all parameters except the setpoint. As a safety feature, the key must be held down for 5 seconds before activation occurs.
Enter	The Enter key by itself performs no function in the normal mode of operation. Therefore it is always used in multi-key operations, i.e. when two or more keys must be pressed simultaneously. In multi-key operations, always first press and hold the Enter key then press the other keys.
left arrow	<u>In auto or remote mode:</u> pressing and holding the Left Arrow will cause the control percent output to be shown in the lower display. Releasing the key will allow the setpoint to be shown in the lower display. <u>In manual mode:</u> the Left Arrow key causes the percent output to decrease by 10 %.
down arrow	The Down Arrow key is only used when in manual mode. Each press of the Down Arrow key will cause the percent output to decrease by 1%.

Marathon Monitors, Inc.

<u>KEY</u>	<u>DESCRIPTION</u>
up arrow	The Up Arrow is used to manually adjust the percent output in the manual mode. Each press of the Up Arrow key causes the percent output to increase by 1%.
Right arrow	The Right Arrow is only used when in manual mode. Each press of the Right Arrow key will cause the percent output to increase by 10 %.
up + enter	This two key combination will perform an LED test whereby every segment and decimal point of the seven segment display and every LED will be illuminated. Should one not light up then it is defective.
right + enter	This two key combination will cause the cold junction temperature to be displayed (in degrees Fahrenheit only) in the lower display as long as the keys are held down. When they are released the display will return to its normal function.
down + enter	This two key combination will cause the input pulse rate to be displayed in the lower display window for the duration of the keypress only. When FAST is selected this rate is in pulses per second, if SLOW is, then the rate is in pulses per minute.

Parameter Entry Modes

There are two parameter entry modes; one activated by the Setpt key and one activated by the Setup key. In both modes, the upper display will show a message describing the parameter being

Marathon Monitors, Inc.

entered. The lower display will show the present value of the parameter and flash the digit that can be **adjusted**. The keyboard functions are redefined as described below:

<u>KEY</u>	<u>FUNCTION</u>
auto/man	In setup mode this key will save the value of the parameter being entered and then display the previous parameter (i.e. it will "backup"). If the parameter being entered is out of range the display will flash and the display remains on that parameter until a valid entry is made.
setpt	If in the Setup mode, then no action occurs. If in the Setpt mode the parameter is saved and since there is only one parameter in Setpt mode, the 10PULSE returns to normal operation.
setup	If in the Setpt mode, then the current parameter is saved and the Setup mode is entered unless the parameter is out of range. If in the Setup mode, the current parameter is saved and then the next parameter is displayed, unless the current parameter is out of range. If the current parameter was the last one in the sequence, then the 10pulse returns to normal operation.
enter	The Enter key saves the current parameter and then returns the 10PULSE to normal operation, unless the parameter is out of range, in which case the unit waits for a valid entry to be made.
left arrow	The Left Arrow is used to select which digit to adjust by moving the flashing digit to the left.

Marathon Monitors, Inc.

Right arrow The Right Arrow is used to select which digit to adjust by moving the flashing digit to the right.

down arrow The Down Arrow is used to adjust the flashing digit. Each press of the Down Arrow will decrease the digit by 1. If the digit is 0 then a press of the Down arrow will change it to a 9 unless the digit is the left most digit and the parameter is allowed to have a negative value then it will change to a "-" and the next press of the Down Arrow will change it to a 9.

up arrow The Up arrow is used to adjust the flashing digit. Each press of the Up Arrow will increase the digit by 1. If the digit is 9 then a press of the Up Arrow Will change it to a 0. If the digit is the left most digit and the parameter is allowed to have a negative value then the 9 will change to a '-' and then a '-' will change to a 0.

Setpt Parameter Mode

The Setpt parameter mode is entered by pressing SETPT and only contains one option.

SETPTLocal Setpoint	The value of the local setpoint (indicated by ????) can range from -300 to 4000. Pressing Setpt or enter after the entry of a new value exits to normal operation.
---------------------	--

Setup Parameter Mode

The Setup parameter mode is entered and stepped through by pressing [SETUP].

	<u>OPTIONS</u>	<u>RANGE</u>
PB ????	Proportional Band	The controller proportional band (indicated by ????) can range from 1 to 999.
rES ??.??	Reset	The controller reset value (indicated by ??.??) can range from 0 to 99.99 repeats per minute.
RAT ??.??	Rate	The controller rate value (indicated by ??.??) can range from 0 to 9.99 minutes.
CYC	Cycle Time	The controller cycle time

Marathon Monitors, Inc.

????		(indicated by ????) can range from 0 to 200 seconds.
LdLn ????	Load Line	The controller load line (indicated by ????) can range from 0 to 100 percent.
AL1 ????	Alarm 1 value	The alarm 1 setpoint (indicated by ????) can range from -300 to 4000.
AL2 ????	Alarm 2 value	The alarm 2 setpoint (indicated by ????) can range from -300 to 4000.

Marathon Monitors, Inc.

AL1t ????	Alarm 1 Type	The alarm 1 type is a number from 0 to 7 (indicated by ????) which is described below: 0 process alarm, direct 1 deviation band, direct 2 deviation, direct 3 percent output, direct 4 process alarm, reverse 5 deviation band, reverse 6 deviation, reverse 7 percent output, reverse
AL2t ????	Alarm 2 Type	The alarm 2 type is a number from 0 to 7 (indicated by ????) as described for the alarm 1 type.
A1t0 ????	Alarm 1 Turn On	Alarm 1 turn on delay in seconds (indicated by ????) from 0 to 200.
A1tF ????	AltAlarm 1 Turn Off	Alarm 1 turn off delay in seconds (indicated by ????) from 0 to 200.
A2t0 ????	Alarm 2 Turn On	Alarm 2 turn on delay in seconds (indicated by ????) from 0 to 200.
A2tF ????	Alarm 2 Turn Off	Alarm 2 turn off delay in seconds (indicated by ????) From 0 to 200.
S 10 ????	SIO setup	The SIO setup is a number from 0 to 31 (indicated by

Marathon Monitors, Inc.

????) which determines the instrument address and baud rate. The address (0 to 15) is added to the baud rate code, 0 for 4800 baud and 16 for 1200 baud, to determine the SIO setup number.

FOR EXAMPLE:

	Address	
	00 01 02 03 04 05 06 07 08 09 10 11 12 13 14 15	
4800	00 01 02 03 04 05 06 07 08 09 10 11 12 13 14 15	
1200	16 17 18 19 20 21 22 23 24 25 26 27 28 29 30 31	
Con ????	Control modes	The control mode is selected by a number from 0 to 7 (indicated by ????) described below:
	0	On/Off control, direct
	1	Time proportioning, single, direct
	2	Time proportioning, dual, direct
	3	Position proportioning, direct
	4	On/Off control, reverse
	5	Time proportioning, single, reverse
	6	Time proportioning, dual, reverse
	7	Position proportioning, reverse

Converted setpoint mode

- 8 On/Off control, direct
- 9 Time proportioning, single, direct
- 10 Time proportioning, dual, direct
- 11 Position proportioning, direct
- 12 On/Off control, reverse
- 13 Time proportioning, single, reverse
- 14 Time proportioning, dual, reverse
- 15 Position proportioning, reverse

Marathon Monitors, Inc.

Note: Converted setpoint mode converts the setpoint to raw input units and then controls based on the difference between the converted value and the raw input. This could provide better control in some applications such as "time in furnace".

AO	Analog Output	The analog output source (indicated by ????) can either be a 0 for the process variable or a 1 for the control percent output.
AOOF ????	Analog Output Offset	The analog output zero starting value can be a value from -999 to 8000. This is used to scale the process variable output range. This value is <u>not</u> used when control percent output is selected.
AOrn ????	Analog Output Range	The analog output range is set by this parameter from 0 to 9999. This value is <u>not</u> used when control percent output is selected.
FAcT ????	Factor	The factor is a multiplier that is used to compute the process variable from the selected input. The range for a factor is from 0 to 9.999. Using factor values of less than 0.200 is not recommended.

Marathon Monitors, Inc.

P10 ????	power of 10	The power of ten is used with the Factor to compute the process variable. A "P 10" value of 2 multiplies by 100 the values range from -3 to +4
dp ????	decimal point	The decimal point selection places the decimal point the desired location for proper display of the process variable in engineering units
IrAt ????	Input rate	The input rate selects the FAST or SLOW input.
Unit ????	Units	The units selects between time or units per time. Time units can be seconds, minutes, hours. Units per time can be whatever the operator chooses such as Revolutions per minute(RPM's), feet per minute, furlongs per fortnight.

Input Scaling

The purpose of the input scaling setup is to have the 10Pulse display the desired process variable in engineering units i.e. time, RPM, feet/minute, etc. The following procedure provides a method of scaling the input without knowing gear ratios, diameters, etc. Section 2.4 describes how the 10Pulse scaling mathematics works for those who wish to mathematically determine the values.

Input Scaling Procedure

- I. Start with the '**FAcT**' set to 1.000 and the '**P10**' set to 0.

- II. The 10Pulse has two methods of reading the input pulses, one is slow and the other fast. The slow input has a maximum pulse rate input of 150 pulses per second and a minimum of 2 pulses per minute. The fast input has a minimum pulse rate input of 2 pulses per second and a maximum of 6000 pulses per second. Set the '**IrAt**' parameter to '**SLO**' for slow and '**FAST**' for fast. If it is not obvious which '**IrAt**' setting to use, start with the slow setting.

- III. Determine if the process being measured is time (i.e. seconds, minutes, hours, etc.) or units/time (i.e. RPM, feet/minute, inches/second, etc.). Set the '**Unit**' parameter to '**PErT**' for units/time and '**TI**' for time.

- IV. Based upon knowledge of the process being measured determine the desired decimal point placement on the display. Set the '**DP**' value to show the desired resolution i.e. '**xxxx.**', '**xxx.x**', '**xx.xx**', or '**x.xxx**' (the x's are shown as place holders only).

- V. Adjust the '**P10**' value until the display reads a value in the same range as the process being measured. The '**P10**' value

Marathon Monitors, Inc.

is a power of 10 factor. Its purpose is to get the display within a factor of 10 of the desired value. A 1 multiplies by 10, a 2 by 100, and a -1 divides by ten. Therefore, if the displayed value is too big, decrease the '**P10**' value. If the displayed value is too small, then increase the '**P10**' value.

VI. The final step is to set the '**FACT**' so that the display reads the process value correctly. This step assumes that there is a way to measure the process being displayed. There are two ways to set the '**FACT**' value. The first way is to divide the actual process value by the displayed value (assuming '**FACT**' is set at 1.000) and enter the result as the '**FACT**' value. The second way is by trial and error as was done in step V. If the displayed value is too small then increase the '**FACT**' value. If the displayed value is too large then decrease the '**FACT**' value.

How the Input Scaling Works

This section describes the difference between the slow and fast inputs and the mathematics used in the input scaling. It is not necessary to understand this information to operate the 10Pulse.

The difference between the slow and fast inputs is how they determine the pulse rate. The fast input counts the number of pulses that occur in 1/2 a second and doubles the number to get pulses per second. The slow input measures the time between pulses. The time in seconds divided into 60 seconds per minute provides the pulse rate in pulses per minute. The 10Pulse uses the pulses per second from the fast input or the time in milliseconds for the slow input for the calculations.

How the process variable is calculated depends on which input is being used and whether the units are time or units/time. Therefore there are four ways to compute the process variable which are shown below.

Input = fast; Units = time

$$PV = \text{Factor} * 10^{P10} / \text{Pulses}$$

Input = fast; Units = units/time

$$PV = \text{Factor} * \text{Pulses} * 10^{P10}$$

Input = slow; Units = time

$$PV = \text{Factor} * \text{Time} * 10^{P10}$$

Input = slow; Units = units/time

$$PV = \text{Factor} * 10^{P10} / \text{Time}$$

Where: PV = process variable
Factor = the multiplier enter as '**Fact**'
P10 = the power of ten entered as '**P10**'
Pulses = the pulses per second measured by the fast input

Marathon Monitors, Inc.

Time = the time between pulses in milliseconds measured by the slow input

The decimal point location is not a part of the calculations and is only used to place the decimal point as desired. It may be necessary to adjust the **P10** value to increase the resolution when the decimal point is used.

The control modes which use the converted setpoint vs input are useful in application where time is being control by varying speed. Since the time-speed relation is non-linear, the control parameters (proportional band, etc.) may have to change when controlling at a low setpoint instead of a high setpoint. The converted setpoint mode converts the setpoint into the equivalent input value. Therefore, the control loop controls to a speed value when the process variable is a time value. Care must be used when using this feature for several reasons. The slow input is a time value and using this method may not change anything. Also, the converted setpoint value is not visible and may have converted to an extremely large number. If the P10 value is not zero or the factor is significantly larger or smaller than 1.000, the appropriate equation above should be used to solve for the converted setpoint. The converted setpoint is the input value that satisfies the appropriate equation when the PV is replaced with the setpoint value.

CALIBRATION

INTRODUCTION

The 10PULSE does not require any input calibration, However the analog output must be calibrated for either voltage or current as required.

Calibration Displays and Keyboard Operation

When in the calibration mode the displays and front panel keys take on special assignments. The process display shows the value of the input being calibrated with a flashing digit. This flashing digit indicates the relative sensitivity of the arrow keys, as described following the key descriptions. The set display indicates whether the zero value or the span value is being modified. The set display messages are as follows:

<u>Message</u>	<u>Description</u>
AI.nu	Zero Analog Input
AI.SP	Span Analog Input
AO.nu	Zero Analog Output
AO.SP	Span Analog Output

It is very important to be sure the set display is indicating the proper mode before making an adjustment or the wrong value will be changed.

In the calibration mode, the following keys perform the described functions:

<u>Key</u>	<u>Function</u>
<-	Increases the adjustment sensitivity. When the adjustment is at the most sensitive position (far left position), a further press of the key loops the adjustment to the least sensitive position (far right position).
->	Decreases the adjustment sensitivity. When the adjustment is at the least sensitive position (far right position), a further press of the key loops the adjustment to the most sensitive position (far left position).
	Increases the indicated calibration factor by the value set with the adjustment sensitivity.
v	Decreases the indicated calibration factor by the value set with the adjustment sensitivity.

Marathon Monitors, Inc.

setpt value.	Presets the Zero or Span calibration factors to the theoretical value.
Enter factors.	Alternates between Zero and Span and saves the calibration factors.
Auto/man	Saves the calibration factors and exits from calibration mode.

Adjustment Sensitivity

The adjustment sensitivity works in the following manner. If the far right digit in the process display is flashing then each press of the up or down arrow key will change the indicated factor by one calibration unit. This is the least sensitive position. If the left most digit is flashing then each press of the up or down arrow key will change the indicated factor by a thousand calibration units. Likewise the middle digits will indicate sensitivities of a hundred and ten calibration units respectively. The input value will usually change by an amount less than the calibration factor; however, by observation of the change, the sensitivity can be selected in order to allow the calibration factors to be adjusted more quickly.

Analog Output Calibration

Introduction

The Analog Output signal can be configured as: 0 to 5V or 4 to 20mA. The output mode for the Analog Output is determined by how the output is wired (See Section 1.25). Any time the mode of operation is switched between current and voltage the output must be recalibrated. The output does not have to be recalibrated when switching between signal types, however.

For example, if the output is calibrated for 0 to 5 volts, and it is desired to change from Process Variable to Proportional Output, no recalibration is necessary (5 volts will be equal to 100%).

Review section 3.1 for operation of the keys during calibration mode. With the Analog output calibration, the Process display (the top set of LEDs) will be all dashes (----).

The Analog Output may be calibrated for other current and voltage ranges : 0-20 mA, 1-5 V, etc. with a slight decrease in signal accuracy.

Calibrating the Output

Marathon Monitors, Inc.

Calibration procedure:

1. Connect the measuring device: recorder, voltmeter, or ammeter to the proper output terminals.
2. Activate the calibration mode by pressing the [Enter] and [Setpt] keys at the same time.
3. Using the Enter key, select the zero mode (display: AO.nu).
4. Using the arrow keys, adjust the output until the measuring device indicates the zero value : 0 volts for voltage, and 4 mA for current.
5. Press the [Enter]key to select span mode (display: AO.SP).
6. Using the arrow keys, adjust the output until the measuring device indicates the span value (i.e. 5 volts for voltage or 20mA for current).
7. Repeat steps 3 through 6 until no additional change is needed.
8. Press Rem/Auto/Man to exit calibration mode

Host Communications

Hardware Description

The HOST communications is RS-485, Half Duplex, even parity and baud rates of 1200 or 4800. Terminal connections are made on the rear panel at TBB-7 and TBB-8. Twisted pair wire with or without a shield must be used for all communications wiring. Conventional RS-232 cable is required along with a half-duplex RS-232/422 convertor (P/N FG/500-0501) .

A typical Host Computer connection, will have the following pins jumpered together as follows:

9-Pin = 1,4,6,8 25-Pin = 5,6,8,20

Consult the Computer's Documentation for your particular connections.

When connected to a host computer the 10PULSE SIO should never be placed into Request mode (the SIO factor under setup must be below 32).

Protocol Format

Response

If an error free and valid message was received by the 10PULSE it will respond with the first character being an (ACK) HEX(06) and then echo the message received inserting any requested data. If an error was detected or an invalid request made, the first character would be a (NAK) HEX(15).**Message**

The message protocol format is displayed, with explanations.
Message Protocol Format

AICdddDLE

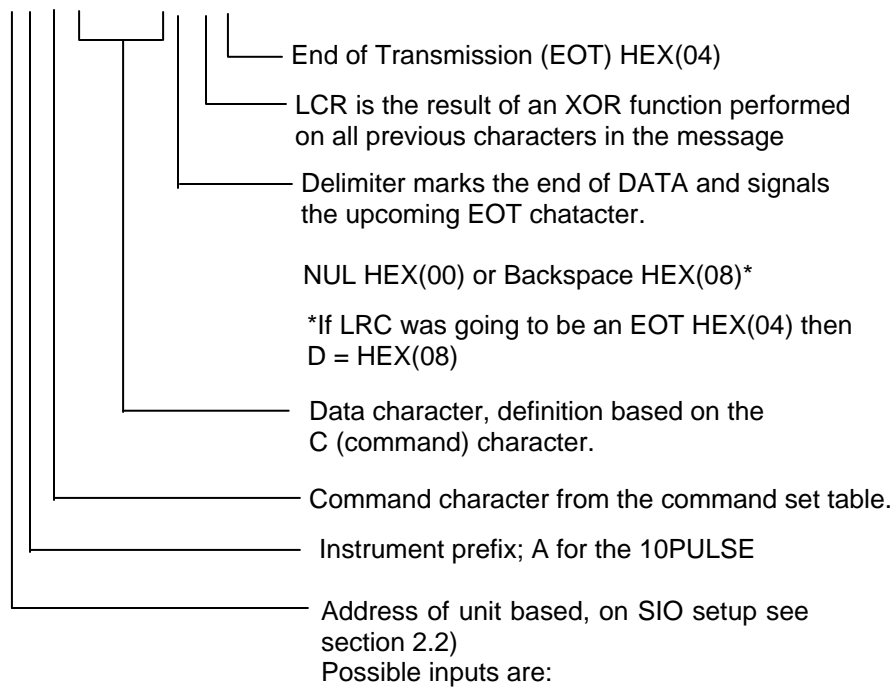

- ASCII
- 0 6 B
- 1 7 C
- 2 8 D
- 3 9 E
- 4 A F
- 5

Command Set

The 10PULSE command set is as follows

<u>COMMAND LETTER</u>	<u>DESCRIPTION</u>
l (as in limits)	Read Process value
m	Read % output
p	Read Auto/Manual mode
o	Read Remote/Local (always responds REMOTE)
i	Read Setpoint
h	Read Setpoint
r	Read Calculated Value #1
s	Read Calculated Value #2
l (as in Instrument)	Update Setpoint Temporarily
J	Update Setpoint Permanently
M	Set % Output and force manual mode
P	Update Auto/Manual mode

- Notes:
- 1) The 10PULSE uses the same Command set as the 10PRO and is therefore compatible with All MMI instrumentation as a 10PRO.
 - 2) All READ commands are lower case letters. All UPDATE commands are upper case letters.