

# Probe Buddy

## Smart O<sub>2</sub> Probe Simulator & Tester



CONNECT WITH US



**MANUAL #: 013**

Revision #	Revision Date	Revision Description
008	February 24, 2020	Description of sections DUAL KEY FUNCTIONS and STANDBY MODE amended
007	August 16, 2018	Instrument Cables included
006	May 23, 2018	Foil revision, process values, cable types, cal and factory mode
005	May 8, 2018	Updated process equations and factor menus
004	April 25, 2018	
003	April 2, 2018	
002	March 22, 2018	
001	September 20, 2017	
000	September 17, 2017	

**COPYRIGHT<sup>(C)</sup>**

No part of this publication may be reproduced, transmitted, transcribed, stored in a retrieval system, or translated into any language or computer language, in any form or by any means, electronic, mechanical, magnetic, optical, chemical, manual, or otherwise, without prior written permission of United Process Controls Inc.

**DISCLAIMER:**

The **PROBE BUDDY** is to be used by the industrial operator under his/her direction. United Process Controls Inc. (UPC) is not responsible or liable for any product, process, damage or injury incurred while using the PROBE BUDDY. United Process Controls Inc. makes no representations or warranties with respect to the contents hereof and specifically disclaims any implied warranties or merchantability or fitness for any purpose.

**TECHNICAL ASSISTANCE**

For all questions or concerns regarding the operation of the PROBE BUDDY, please consult the last page of this manual for contact information.

# Table of Contents

<b>1</b>	<b>DESCRIPTION.....</b>	<b>5</b>
1.1	LCD Graphic Display .....	5
1.2	Signal Connectors .....	5
1.3	Keyboard .....	6
1.3.1	Single Key Functions .....	6
1.3.2	Dual Key Functions.....	7
1.4	Normal Operation .....	7
1.5	Standby Mode .....	8
1.6	Input Mode .....	9
1.6.1	Using Input Mode.....	9
1.7	Output Mode.....	9
1.7.1	Using Output Mode .....	10
1.8	Probe Test Mode .....	11
1.8.1	Why Measure Sensor Impedance?.....	11
1.9	Alarm Display .....	12
<b>2</b>	<b>SETUP MENU.....</b>	<b>13</b>
<b>3</b>	<b>PROCESS FORMULAS .....</b>	<b>17</b>
3.1	Carbon Formula.....	17
3.2	Dew Point Formula .....	17
3.3	Oxygen Formula .....	18
<b>4</b>	<b>CALIBRATION .....</b>	<b>19</b>
4.1	Calibration Displays and Keyboard Operation.....	20
4.2	Preparing for Input Calibration.....	21
4.2.1	Calibration of Inputs .....	21
4.3	Preparing for Output Calibration.....	22
4.3.1	Calibrating the Outputs Signals.....	22
4.4	Calibration of Cold Junction.....	22
<b>5</b>	<b>DIAGNOSTIC ALARMS .....</b>	<b>23</b>
<b>6</b>	<b>BATTERY REPLACEMENT .....</b>	<b>23</b>
<b>7</b>	<b>TECHNICAL DATA.....</b>	<b>24</b>
7.1	LCD Graphic Display .....	24
7.2	Analog Signals.....	24
7.3	General.....	25

7.4	Standards Conformity.....	25
<b>8</b>	<b>REFERENCES.....</b>	<b>25</b>
8.1	Available Cables:.....	25

# 1 DESCRIPTION

The United Process Controls Sensor Simulator and Tester (PROBE BUDDY) has been designed for the maintenance or system engineer in mind. The PROBE BUDDY gives the operator a valuable tool for testing any UPC oxygen sensor as well as the ability to simulator a working sensor connected to process control systems.

The important features of the tester are:

- Operates as sensor test/meter or sensor signal simulator
- Accepts selectable TC and mV inputs from any oxygen sensor
- Outputs selectable TC and mV signals to simulate an oxygen sensor
- Performs a sensor impedance test when connected to the sensor
- Computes carbon, dewpoint or oxygen in input or output mode
- Low power LCD display for HMI
- Small hand-held package
- Easy access connections on the top panel
- Operates on standard 9V battery

## 1.1 LCD Graphic Display

The LCD display is a low power 132x32 Pixels graphic display, equivalent to 4x22 characters.

## 1.2 Signal Connectors



There is a sensor millivolt and sensor thermocouple connector located on the top of the PROBE BUDDY. The standard T/C connector is a B type standard mini-thermocouple plug with alligator clips. The millivolt connector is a standard banana plug with alligator clips. Optional cables are available that provide mating connectors for UPC probes – Carbonseer, Quicksilver, AccuCarb, AtmoProbe – and other sensors and installed cables. See the table in the reference section of this manual for a list of available cables.

### 1.3 Keyboard

The PROBE BUDDY keyboard has eight keys that operate as individual keys or in combinations of two keys.

These keys are separated into two groups, the mode group and the navigation group.



Figure 1 Mode Group Keys

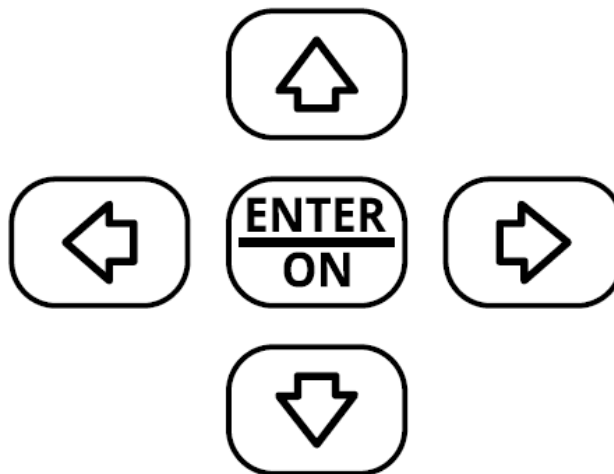
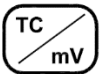



Figure 2 Navigation Group Keys

Each key has a principal function, but combo keys can be used for additional operations.

#### 1.3.1 Single Key Functions

 **TC / mV** toggles between the TC and mV selection when configured for output mode. It also serves to move the cursor from the TC to the mV values. Use the arrow keys to position the cursor and change the digit value.

 **IN / OUT** selects the IN/OUT mode. Both the millivolt and T/C signals shift from input to output when this button is toggled. Output levels for either signal can be adjusted, if ramp mode is not active. When input mode is selected, the actual signal levels are displayed and are not adjustable.

 **Setup** allows access to the setup menu. Press and hold for 5 seconds to enter Setup mode.



**Enter / ON** starts up the simulator and allows data entry in the setup mode. Press and hold the Enter key for 1 second to turn on and 5 seconds to turn off. The Enter key sets values or parameter selections, once required changes have been made. The Enter key will shift to different display windows when the PROBE BUDDY is in input mode.



**Left Arrow** moves the digit cursor to the left in output mode or moves left through the main menu selection in setup mode.

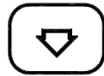

**Down Arrow** decreases the selected digit value in output mode or moves down the selected setup menu.



**Up Arrow** increases the selected digit value in output mode or moves up in the selected setup menu.

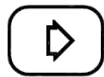

**Right Arrow** moves the digit cursor to the right in output mode or moves right through the main menu selection in setup mode.

### 1.3.2 Dual Key Functions

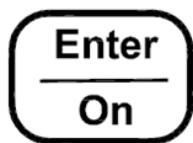
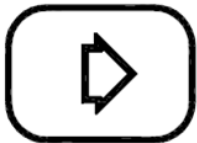

#### **Right Arrow + Enter / ON**

Pressing the Right Arrow and Enter keys simultaneously starts or stops the sensor test.



#### **Left Arrow + Enter / ON**

Pressing the Left Arrow and Enter keys simultaneously, when PROBE BUDDY is in Standby mode, switches to Service mode.

## 1.4 Normal Operation

The following figure shows the PROBE BUDDY display layout.

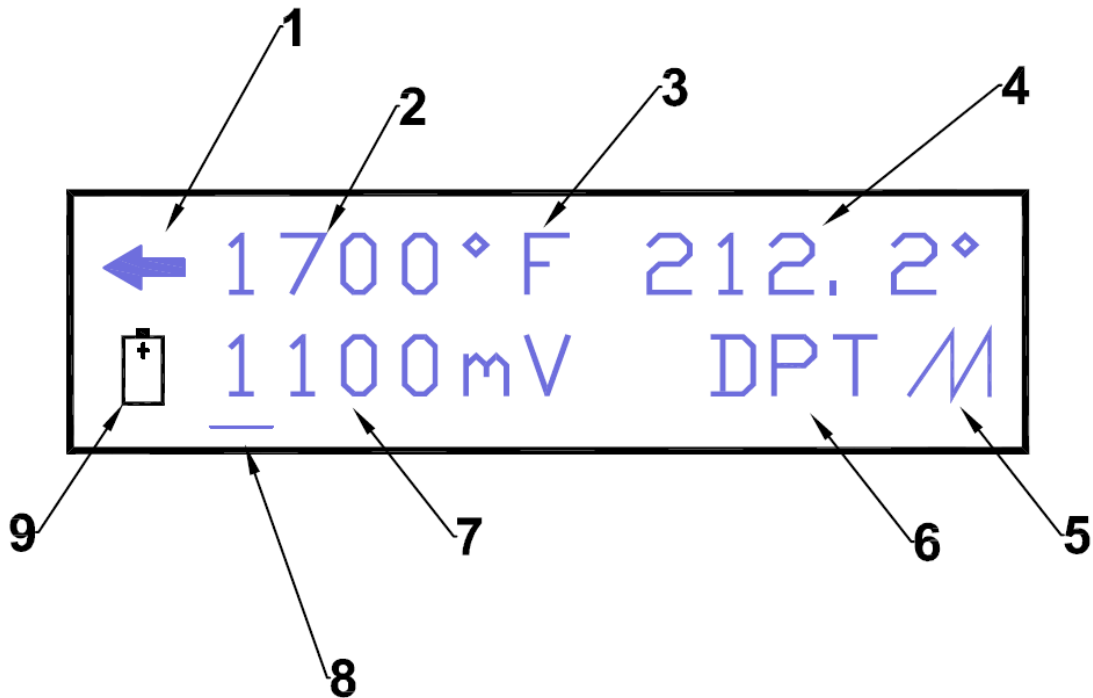

1. **SIGNAL DIRECTION ICON** - Changes the signal direction of both the thermocouple and millivolt signal by pressing the **IN/OUT** key. Left arrow (pointing out) indicates output mode. Right arrow (pointing in) indicates input mode.
2. **TEMPERATURE** – Display of thermocouple signal is based on the thermocouple type and temperature scale (°C/°F) selected in the setup menu.
3. **TEMPERATURE SCALE** – Indicates the temperature scale
4. **PROCESS VALUE** – Selected process is displayed here based on the temperature and millivolt signals, either inputs or outputs. The scale will change according to the process.
5. **RAMP** – Indicates that the selected output signal is ramping from a selected start and stop range. The ramp function is enabled in the **SETUP / OUTPUTS** menu. One or both outputs will ramp if enabled. Changing values are displayed.
6. **PROCESS** – Indicates the selected process: DPT for dewpoint, %C for carbon, %O2 for oxygen, and PPM for %O2 values below 00.01% oxygen.
7. **SENSOR MILLIVOLTS** – Shows the measured or set sensor millivolt output.
8. **DIGIT CURSOR** – Cursor indicates the digit selected to change. The cursor shifts from temperature to millivolts when the **TC/MV** key is pressed. The arrow keys change the cursor position and digit value. The cursor is only available when the signal output mode is selected.
9. **BATTERY LOW ICON**– Indicates when the battery power is low and should be replaced.

## 1.5 Standby Mode

The PROBE BUDDY is in standby mode when the display is blank. The unit will turn on when the Enter key is pressed for 1 second. The unit has an adjustable wake state time that can be selected in the **SETUP / DISPLAY / SLEEP MODE SHUTDOWN** parameters. This setting



determines how long the unit will remain on, without any key being pressed, during the specified period of time. This feature is available to minimize power drain on the battery.

## 1.6 Input Mode

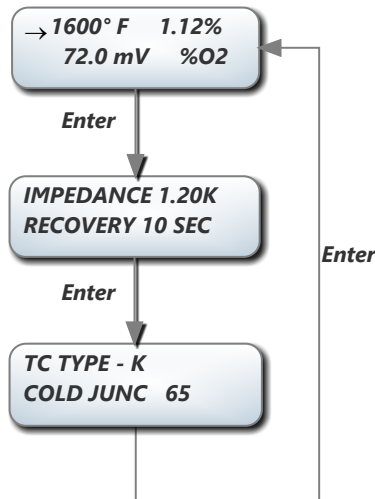

The input function has been selected with the calculated oxygen display for the thermocouple and millivolt input signals. Pressing the Enter key cycles between the available displays

### 1.6.1 Using Input Mode

Input mode is used to check or test the outputs of a sensor in a working furnace. The sensor should be at or above its minimum temperature range 1100°F (600°C). Disconnect the sensor from the monitoring or control system and connect the PROBE BUDDY to the TC and mV signal connections from the sensor.

If you are using the cable set with alligator clips, there will be a cold junction error introduced to the temperature measurement, but the intention here is to confirm operation of the TC and confirm the process value.

## 1.7 Output Mode

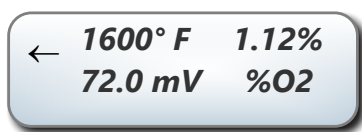

The output function has been selected with the calculated oxygen display for the selected thermocouple and millivolt outputs. Pressing the TC/mV key cycles between the TC/mV output values. The ◀ or ▶ keys move the cursor on the digits of the value selected.

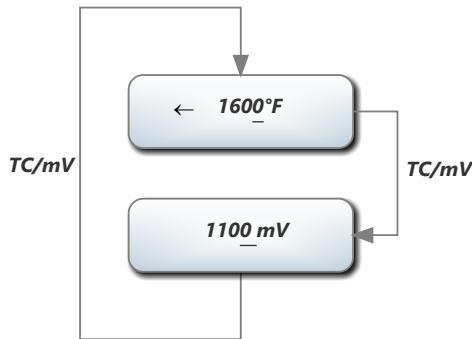

Output mode only displays the signal screen but allows the operator to cycle between the TC setting and the mV setting.

The position of the cursor is indicated by the flashing cursor under the selected digit.

This method is much more efficient than the 'press and wait' method and allows the operator to instantly change the magnitude of the output.

The flashing cursor indicates which digit can be changed by pressing the up or down arrows to increase or decrease the value. The digit will change with each key press. Each digit value cycles from 0 to 9 or 9 to 0 when the arrow keys are continually pressed.

## Value Change

### Up/Down Arrow

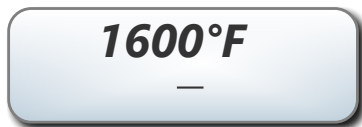

Left ← → Right  
**Cursor Shift**

The operator can change the position of the cursor with the discrete right or left arrow key presses. The cursor will continually shift from LSD to MSD or MSD to LSD if the arrow keys are continually pressed.

This scheme allows the operator to change the output values quickly without having to wait for fixed or dual speed value changes and the need to time the key release. The output signal changes and settles to the selected value as soon as the Enter key is pressed. The displayed process value is recalculated with the new output values and displayed.

### 1.7.1 Using Output Mode

The PROBE BUDDY is used in output mode to test and verify that the monitoring or control instruments are working or to simulate changes in the sensor signals using the ramp mode for either or both signals. To modify the process, it is generally more useful to ramp only the mV signal and set the temperature output to the typical operational level.

To set up for output mode:

- Change PROBE BUDDY to output mode by pressing the IN/OUT key until the signal direction icon points left (out).
- Using the correct TC cable, connect the TC leads to the instrument thermocouple inputs. Observe the polarity of this connection. The negative lead of thermocouples is typically the red wire. NOTE: B type TC connections can be made with standard copper wire.
- Connect the mV cable to the instrument millivolt inputs. Observe the polarity of this connection.
- Move the digit cursor to the TC display by pressing the TC/mV key if it is not already flashing under the TC value.
- Press the ◀ or ▶ keys to move the cursor, and use ▲ or ▼ keys to change digit value.

## 1.8 Probe Test Mode

The probe impedance test is performed by measuring the voltage of the probe, applying a known shunt resistor across it, and then measuring the shunted voltage output. The value of the shunt resistor is 10kohm for oxygen sensors.

To run a probe impedance test it is necessary to setup the probe testing parameter in the SETUP Probe Menu, and the PROBE BUDDY is configured for signal inputs. Please refer to Probe parameters table for an explanation of these setup parameters. You may choose to accept the defaults for the other parameters in this menu or change them to suit your applications. It is necessary that the sensor be above the MIN PROBE TEMP parameter setting for this test to run. It is also necessary for the probe to measure a stable process gas during this test. To start the test, press the ENTER and ► keys at the same time. The test can be stopped by pressing the ENTER and ► keys again.

The following table explains the operations of the impedance test. The PROBE BUDDY will display the averaging time countdown and the results.

Sequence #	Description
1	Inhibit process variable calculations
	Freeze alarms at last state except clear any previous probe test failure alarm
	Store present probe millivolt reading
	Apply shunt resistor across probe
2	Wait for impedance test timer, fixed time of 30 seconds
	Compute impedance of probe and remove shunt resistor. Save measured impedance as PROBE IMPEDANCE in INFO menu.
	If impedance is greater than PROBE IMP LIMIT, then set probe test failure alarm.
3	Wait for probe to recover to >=99% of original millivolts
	Evaluate actual recovery time to IMP RECVRY TIME
	If recovery time is greater than IMP RECVRY TIME, then set probe test failure alarm.
	Store recovery time (or max value) as IMP RECVRY TIME in INFO menu

### 1.8.1 Why Measure Sensor Impedance?

It is important to track sensor impedance over a period of time to help determine the replacement schedule for the sensor. A high impedance (>50 KΩ) indicates that the electrode contact on the probe zirconia is deteriorating to a level that probably warrants replacement. High sensor impedance results in a lower signal output from the sensor and an eventual failure of the electrode connection on the process side of the zirconia ceramic. This deterioration is more of a factor in highly reducing atmospheres. In such applications, it may be necessary to check the impedance at least once a month. Under light reducing, annealing, or brazing operations, the impedance may not have to be checked unless there is a question about the probe's performance.

A typical impedance for a new probe is less than 1 KΩ. As the probe starts to age, the impedance will increase. Past 20 KOHM the sensor should be monitored more closely. Above 50 KΩ, the sensor should be replaced. If it is necessary to replace the sensor, remove it carefully following the instructions supplied with the sensor. Do not discard a sensor with a high impedance. It may be possible to rebuild the sensor if the ceramic parts are intact. Contact United Process Controls for information on rebuilding your sensor. An impedance test can only be performed if the probe temperature is at or above 1100°F (600°C) with a stable atmosphere present.

A 10KΩ resistor is shunted across the sensor output. The sensor impedance is calculated as:  
$$R_x = [(E_o/E_s)-1]*R_s$$

Where  $R_x$  = sensor impedance,  $E_o$  = sensor's open circuit voltage,  $E_s$  = shunted sensor's voltage, and  $R_s$  = shunt resistor. The units of  $R_x$  are the same as  $R_s$ .

**Probe Test  
Recovery Time**

The Sensor test process screen is displayed while a test is running.

If the Enter/▶ dual keys are pressed while the PROBE BUDDY is configured for outputs, the display will momentarily display the message - CHANGE TO INPUT MODE.

## 1.9 Alarm Display

Alarm display alerts the operator about a fault in the PROBE BUDDY or signals exceeding the limits of the inputs.

**ALARM  
FLASH CSUM**

A major fault or alarm screen must be acknowledged using the Enter key. System fault alarms will reoccur if the fault continues.

→ **HHHH°C    0.00%**  
**72.0mV    %O2**

High value displays when the signal exceeds the display or maximum limit of the signal input.

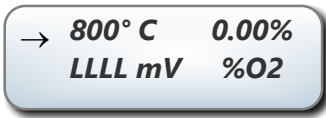

Low value displays when the signal exceeds the display or lower limit of the signal input.

## 2 SETUP MENU

Holding the Setup key for 5 seconds opens the Setup Menu.

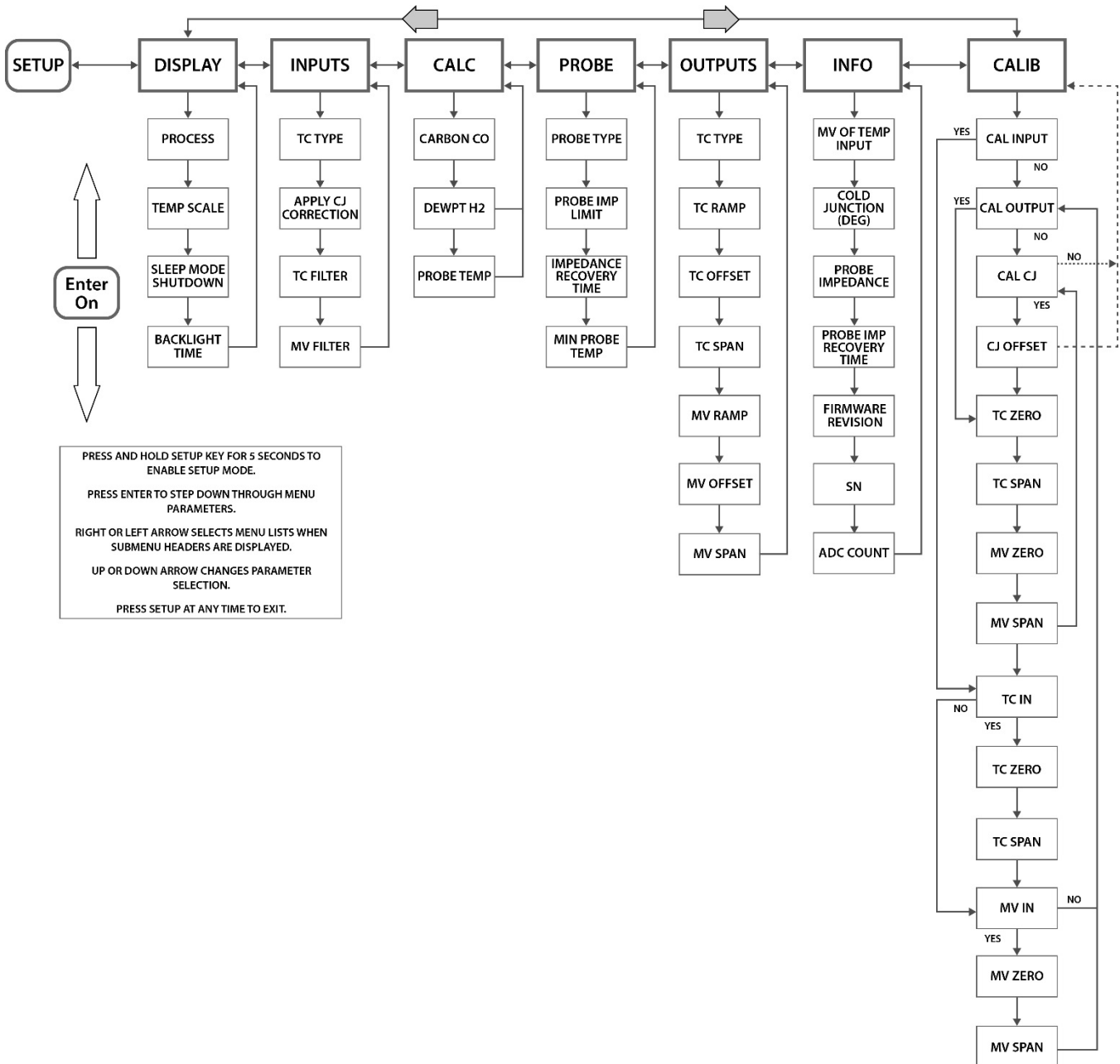

Press the ◀ or ▶ keys to move the display across the main categories of the setup menu. The Enter key selects the category and then moves the display vertically down the selected menu. Menu or parameter lists loop back at the end of any menu or category.

**Display** Selects the process for calculation and display: carbon, dew point, and oxygen. The Sleep Mode Shutdown parameter allows for different shut down times.

### Display Menu

Parameter Name	Units or Options	Range	Review
PROCESS	Carbon, Dewpt, O2	Display range: Carbon: 0-2.55% Dewpt: -99.9 to 212.0°F (-73 to 100°C) O2: 0.01%-20.9% (ppm below 0.01%, 9999ppm to 100ppm)	Selects the process value that is displayed with the temperature and mV values.
TEMP SCALE	F OR C		Sets temperature scale for temperature display and dewpt calculation.
SLEEP MODE	1, 5, 10, 30, ALWAYS ON	Select number values (mins) or ALWAYS ON to disable the sleep mode.	Sets the time the PROBE BUDDY will stay on after the last key press. If there is no key press after the selected period of time, the PROBE BUDDY goes into standby mode.
BACKLIGHT TIME	ALWAYS ON, 1 sec, 5 sec, 10 sec, 30 sec, 1 min, 5 min	Select number values or ALWAYS ON (Default)	Sets the time the backlight will stay on after the last key press. If there is no key press after the selected period of time, the backlight turns off but the display is still active. Backlight returns on next key press.

**Inputs** Selects TC type (B, K, R, S), temperature scale (C or F), and averaging for TC and mV inputs.

### Input Menu

Parameter Name	Units or Options	Range	Description
TC TYPE	K, R, S, B	See TC reference table	See Input calibration for thermocouple ranges.
APPLY CJ COMP	YES or NO		Applies the cold junction correction or not when a thermocouple type is selected. Default is YES.
TC FILTER		0 – 450	Temperature filter setting in seconds. Filters the temperature

Parameter Name	Units or Options	Range	Description
			value with a moving average time window.
MV FILTER		0 – 450	Millivolt filter setting in seconds. Filters the millivolt reading with a moving average time window.

**Calculations** Select and edit CO or hydrogen compensation value.

### Calculation Menu

Parameter Name	Units or Options	Range	Description
Carbon CO	%	1-50	Adjusts the CO value to accommodate for changes in the sensor or the furnace. Default is 20.
Dewpt H2	%	1-99	Used in the dewpt equation with a default value of 40.

**Probe** Selects impedance limits, test recovery limit, and minimum temperature limit for test. The impedance test is only active in input TC/mV mode.

### Probe Setup

Parameter Name	Units or Options	Range	Description
PROBE IMP LIMIT	KOHMS	10 – 100	Sets maximum impedance for Probe alarm
IMPEDANCE RECOVERY TIME	SECONDS	0 – 250	Sets maximum Probe recovery time, timer cut short if probe recovers faster. The Probe alarm is set if the probe signal does not recover while this timer is active.
MIN PROBE TEMP	°F or °C	0 – 3000	Tests input temperature reading to allow for sensor test. Reading > Min Temp then allow impedance test.

**Outputs** Selects TC type (B, K, R, S). Set the ramp time base or 0 to disable. Set temperature offset and span values for ramp range. Set the MV ramp time base or 0 to disable. Set MV output offset and span for ramp range. Ramps can be enabled for TC, MV, or both. If any ramp time is > 0, then ramp(s) start as soon as the PROBE BUDDY is returned to normal operation.

### Output Menu

Parameter Name	Units or Options	Range	Description
TC TYPE	B, K, R, S	See TC reference table for required output range	See Input calibration for thermocouple ranges.

Parameter Name	Units or Options	Range	Description
TC RAMP	0, 30, 45, 60	Ramp rate in seconds	0 disables ramp function. Ramp is a sawtooth with ramp from offset to span and drop back to offset.
TC OFFSET	In F of C scale depending on TEMP SCALE selection	32-5432°F Or 0-3000°C	This is the minimum value the ramp function. Default is minimum of selected TC type. Updated only when TC type changes.
TC SPAN	In F of C scale depending on TEMP SCALE selection	32-5432°F Or 0-3000°C	This is the maximum value the ramp function. Default is maximum of selected TC type. Updated only when TC type changes.
MV RAMP	0, 30, 45, 60	Ramp rate in seconds	0 disables ramp function. Ramp is a sawtooth with ramp from offset to span and drop back to offset.
MV OFFSET	Starting value on mV signal for ramp output.	0 – 2000mV	This is the minimum value of the ramp function. Default for carbon and dewpoint is 1000mV, 0mV for oxygen process.
MV SPAN	Maximum value of ramp	0 – 2000mV	This is the maximum value the ramp function. Default for carbon and dewpoint is 1800, 80mV for oxygen.

**Info** General Information with diagnostic information.

### Info Menu

Parameter Name	Units or Options	Range	Description
MILLIVOLT TEMP IN	MILLIVOLTS	0 to 100	Displays direct mV of Temperature input. Shows 0 if mode is set to output.
COLD JUNCTION	DEG (F OR C)	-20 to 255°F -29 to 124°C	Displays actual cold junction temperature
PROB IMPEDANCE	Kohms	0 to 255	Displays last probe impedance value.
IMP RECVRY TIME	SECONDS	0 to 250	Displays last impedance recovery time.
FIRMWARE REV	Version number		Refer to this number prior to service.
SERIAL NUMBER	Serial Number		Refer to this number when returning the device for service



### 3 PROCESS FORMULAS

There are three main process formulas available: carbon, dew point, and oxygen. The carbon and dew point formulas assume an endothermic atmosphere in equilibrium.

#### 3.1 Carbon Formula

The primary factor effecting this process is the amount of carbon monoxide, normally assumed to be 20%. This calculation is accurate for endothermic atmospheres operating in equilibrium, but the CO correction variable allows for adjustment of the carbon calculation based on actual %CO readings or results from material tests. The PROBE BUDDY's sensor millivolt output simulates the signal from an in-situ zirconia sensor. The T/C output simulates the integrated temperature T/C in the oxygen sensor.

$$\%Carbon = 5.102 * \frac{e^{(Eo-786)/0.043102Tk}}{(4728.5 * (.20 / CO)) + e^{(Eo-786)/0.043102Tk}}$$

Where: Tk = Sensor temperature Kelvin  
 Eo = Sensor millivolt output  
 e = natural log  
 CO = Variable CO%

CO is a user variable that can be changed in the SETUP / CALC / CO/H2 parameter. The default for this variable is 0.20. The .20 in the numerator of the CO ratio assumes 20% in a normal endothermic process.

##### Test Case 1:

Temp = 1600°F = 1144.261K  
 mV = 1050  
 CO = 0.20  
 %Carbon = 0.2182

##### Test Case 2:

Temp = 1700°F = 1199.817K  
 mV = 1155  
 CO = .17  
 %Carbon = 0.9397

The displayed %Carbon value will be rounded up to X.XX. Displayed value range is 0 - 2.55%.

#### 3.2 Dew Point Formula

The primary factor effecting this process is the amount of hydrogen, normally assumed to be 40%. This calculation is accurate for endothermic atmospheres operating in equilibrium. The

PROBE BUDDY’s sensor millivolt output simulates an in-situ zirconia sensor. The T/C output simulates the integrated temperature T/C in the oxygen sensor. The result of the calculation is dew point in °F.

$$DP = (4238.7 / (9.55731 - \text{LOG}_{10}(\text{PH}_2) + (\text{mV} - 1267.8) / (0.05512 * \text{Tr}))) - 460$$

mV = millivolts  
 PH<sub>2</sub> = partial pressure of hydrogen (default = .40)  
 TR = Temp Rankin  
 DP = dew point °F (or °C if converted)

Test Case:

H2%	Temp F	Temp R	mV	DewF	DewC
0.40	1652.00	2111.67	1100	37.873	3.263
0.40	1652.00	2111.67	1000	93.755	34.308
0.40	1472.00	1931.67	900	192.020	88.900
H2%	Temp F	Temp R	mV	DewF	DewC
0.30	1652.00	2111.67	1100	30.673	-0.737
0.30	1652.00	2111.67	1000	84.862	29.368
0.30	1472.00	1931.67	900	179.725	82.070

The displayed dew point value is rounded up to XXX.X. This result in Fahrenheit is converted to Celsius, if Celsius is selected as the temperature scale.

The displayed range of values is -99.9°F (-73.3°C) to 212°F (100°C).

This calculation is only valid for an endothermic atmosphere in a state of equilibrium. The equation is not accurate for a dew point of exothermic gases or other applications.

### 3.3 Oxygen Formula

The oxygen calculation is based on the sensor millivolt output of an in-situ zirconia sensor with a 20.9% reference oxygen and an integral temperature sensor. There are no adjustments to the calculation.

$$\%O_2 = 0.2095 / e^{(\frac{E_o}{0.0215TR})}$$

Where: Tk = Sensor temperature in Kelvin  
 Eo = Sensor millivolt output  
 e = natural log

Test Case:

Temp = 1425°C = 1698.15K  
 Eo = 85mV  
 O<sub>2</sub> = 0.02042 → 2.042%

The displayed percent oxygen value is rounded to XX.XX. As the oxygen value drops below the least significant digit (00.01%), the display will automatically shift to X.X PPM. No additional adjustment factors are required. Zirconia sensors can read very low oxygen

conditions, and the PROBE BUDDY can simulate these conditions. However, calculated oxygen values in the ppm range do not agree with volumetric ppm readings and are not displayed numerically.

Oxygen calculation range: 0.1 PPM to 20.9%

## 4 CALIBRATION

There are two analog signal connections that function as inputs or outputs and a cold junction compensation sensor on the thermocouple connector. The input level is determined by which terminals are used for the input signal.

Make sure the PROBE BUDDY is turned off. Then follow the steps listed in the following figure. Press and hold the Left Arrow and then the Enter key until the PROBE BUDDY turns on.

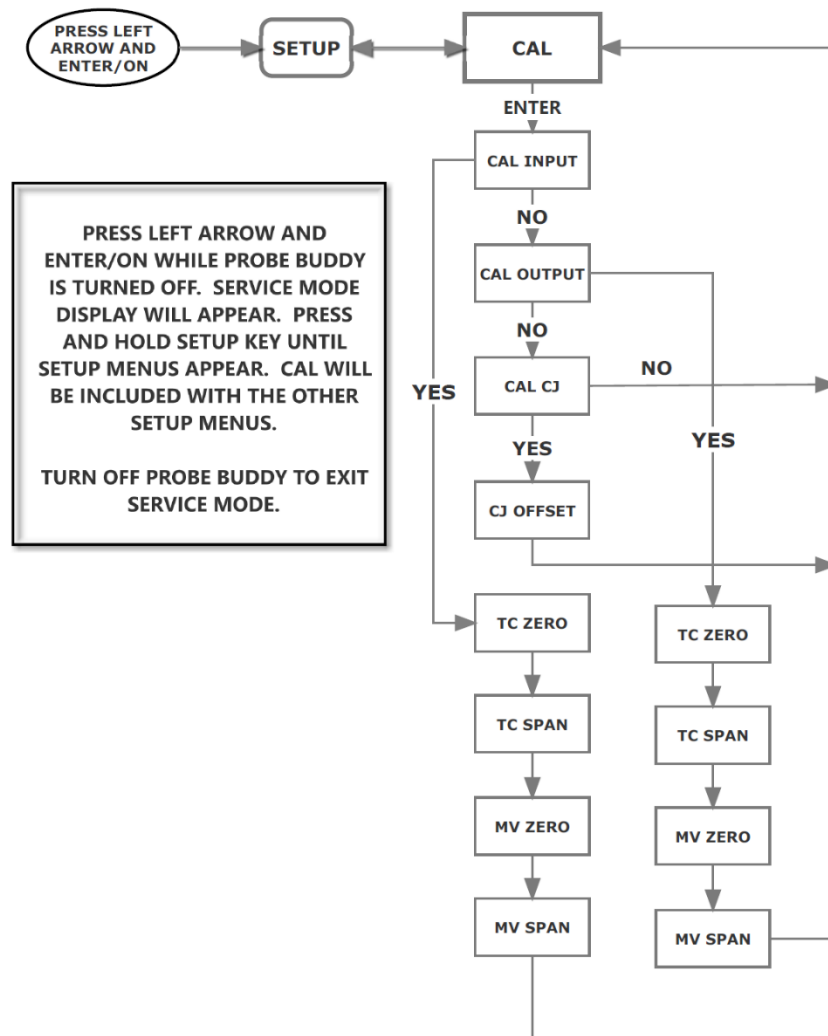

When the PROBE BUDDY powers up in SERVICE mode, the display appears as shown below:



Both the TC and mV values show the input signals in mV. If these values match the mV signal inputs then only the cold junction calibration may be necessary.

Change to Output mode and enter typical values for the TC mV and mV outputs. Make sure the TC and mV connections are plugged into mV meters to verify the output signals. The following figure shows the output for TC set to 10mV and the output for MV set to 500mV

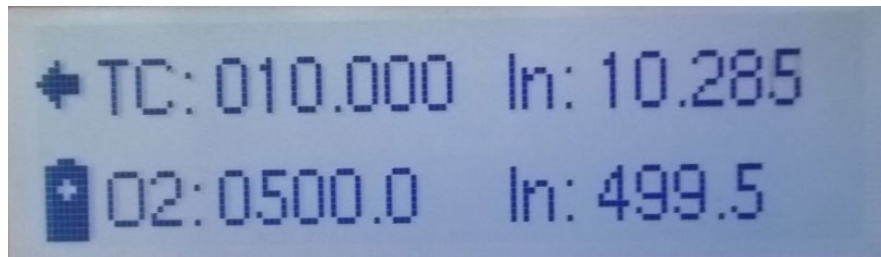

If the same values are shown on the attached mV meters, then it is not necessary to calibrate the outputs.

The only measure that may need calibrating is the Cold Junction (input).

#### 4.1 Calibration Displays and Keyboard Operation

When entering the Calibration Menu, the operator has to answer questions depending on which I/O functions have to be calibrated. If the CAL INPUT prompt selection is YES, then the parameters related to the thermocouple input and millivolt input can be changed. If this prompt is skipped by pressing the Enter key, then a second prompt, CAL OUTPUT is displayed. If this prompt is answered with a YES, then the preset outputs for TC and MV zero and span will be generated. The operator can adjust values for each setting to match these preset values.

In the Calibration Menu, the display and panel keys function similar to other modes. The LCD display shows the input and calibration point being calibrated. The upper line of the display indicates that the instrument is in CAL mode. The lower display line indicates the actual input or output level at the connection selected.

It is very important that the display indicates the proper type and zero or span parameter before making an adjustment, otherwise the wrong value will be changed.

Once the particular calibration mode is selected, the following keys perform the described functions:

<u>Key</u>	<u>Function</u>
UP ARROW	Increases the displayed value.
DOWN ARROW	Decreases the displayed value.
RIGHT ARROW	Shifts the cursor to the upper digits to adjust the calibration factor. The most significant digit of the display has the most effect on the displayed value.
LEFT ARROW	Shifts the cursor to the lower digits to adjust the calibration factor. The least significant digit allows for the smallest adjustment.
ENTER	Moves to the next calibration step and saves the calibration changes. Wraps back to the CAL menu heading, if continually pressed.
SETUP	Exits Cal mode, saves any changes, and returns to normal operation mode.

## 4.2 Preparing for Input Calibration

The following items are required to calibrate thermocouple and millivolt inputs. The TC extension wire and calibrator setting must match the PROBE BUDDY thermocouple setting.

- Calibrated millivolt source, 0 – 2000mV with a 0.1 mV resolution
- Calibrated TC millivolt source, -10mV to 70mV with a 0.1 uV resolution
- Copper wire with banana plug to connect millivolt source mV input
- Copper wire with uncompensated mini-thermocouple plug to connect the TC mV source to the TC input
- Calibrated thermocouple simulator with internal cold junction compensation
- Thermocouple extension wire and similar mini thermocouple plug for the type of thermocouple to be used

The TC zero and span calibration is done with the mV source. The cold junction calibration is done with the TC source and set to the same thermocouple type as the PROBE BUDDY.

### 4.2.1 Calibration of Inputs

Calibration procedure:

1. In Calibration mode, press and hold the SETUP key to go to setup mode.
2. Press the ◀ or ▶ keys until the CALIB menu is shown.
3. Press Enter to go to CAL INPUT, press the ▲ or ▼ key to select Yes.
4. Press Enter to display the TC 0mV page.
5. Use a TC millivolt source with copper wire. Connect to the TC input connector.
6. Set the source output for 0.000mV.
7. Press Enter. The input will be averaged and the calibration values set.
8. The TC 100mV page is displayed.
9. Set the source output to 100.000mV.
10. Press Enter. The input will be averaged and the calibration values set.
11. Display changes to MV 0mV.
12. Connect mV source to mV connect and set to 0.00mV.

13. Press Enter. The input will be averaged and the calibration values set.
14. Display changes to MV 2000mV.
15. Change mV source output to 2000.00mV.
16. Display will show CALIBRATION SAVED
17. Continue to Output Calibration or Cold Junction calibration or press SETUP to escape.

### **4.3 Preparing for Output Calibration**

The following items are required to calibrate thermocouple and millivolt outputs. The TC extension wire and calibrator setting must match the PROBE BUDDY thermocouple setting.

- Calibrated millivolt meter, 0 – 2000mV with a 0.1 mV resolution
- Calibrated millivolt meter, -10mV to 70mV with a 0.1 uV resolution
- Copper wire with banana plug to connect millivolt meter PROBE BUDDY MV jack.
- Copper wire with uncompensated mini-thermocouple plug to connect a meter to the PROBE BUDDY TC jack.

#### **4.3.1 Calibrating the Outputs Signals**

The same calibration procedure can be used for either output channel. The difference is in the mV level: 0-100mV for the TC output and 0-2000mV for the sensor millivolt output.

1. At CAL OUTPUT, change No to Yes.
2. Press Enter to display the TC 0mV page.
3. Use a millivolt meter with copper wire and an uncompensated TC connector.
4. Connect to the TC connector to the PROBE BUDDY.
5. Adjust the number displayed on the second line of the PROBE BUDDY to read 0mV on the meter. Allow the reading to stabilize between adjustments.
6. Press Enter when the meter reading is averaging around 0.000mV.
7. The TC 100mV page is displayed.
8. Adjust the number on the second line until the meter reading is averaging around 100.000mV.
9. Press Enter.
10. Display changes to MV 0mV.
11. Adjust the number on the second line until the meter reading is averaging around 0.00mV.
12. Press Enter.
13. Display changes to MV 2000mV.
14. Adjust the number on the second line until the meter reading averages around 2000.00mV.
15. Display will show CALIBRATION SAVED

### **4.4 Calibration of Cold Junction**

1. Connect the thermocouple extension wire and plug for the type of thermocouple selected in the PROBE BUDDY INPUTS / TC TYPE parameter.
2. Set the calibrator to 25°C.

3. In the OFFSET screen, enter a plus or negative value that will correct the R value on the right to 25°.
4. Press Enter to save the cold junction offset.
5. Display will show CALIBRATION SAVED
6. The display will return to CALIB.
7. Press the SETUP key to return to the Calibration mode display.

## 5 DIAGNOSTIC ALARMS

Diagnostic alarms are shown on the display when a fault is detected in the internal hardware during power up. These alarms included:

EEPROM CSUM FAULT	A fault has been detected in the EEPROM.
ADCx FAULT	The analog / digital converter 1 or 2 has failed to initialize or failed self-calibration.
LOW	Low Battery power detected and displayed before shut down.
LOW TEMP	Displays in step 1 of the sensor test screen, if the input temperature is too low for the sensor to function. Oxygen sensors operate at temperatures above 1100°F (600°C). This value is set in the Setup menu / PROBE / MIN PROBE TEMP parameter. This value can be modified or disabled if the temperature is not connected as an input, assuming the sensor is operating above the minimum range.
CHANGE TO OUTPUT MODE	This prompt displays temporarily when at sensor test is attempted but the PROBE BUDDY is in the output mode. The sensor test can only run when the PROBE BUDDY is connected to a valid sensor mV signal.

The front panel display will show **LLLL** if the process value is below the display resolution or signal range. **HHHH** will appear as the process value if signal is above the input range or display resolution. It may be necessary to adjust the exponent and/or the decimal point settings if these symbols occur.

Multiple alarm conditions can be seen by pressing the Enter key to cycle through active alarm displays.

## 6 BATTERY REPLACEMENT

When the battery replacement icon appears, it will be necessary to replace the 9V battery. The battery is accessible on the back of the case near the bottom edge. Slide the battery cover down and replace the battery.

Please follow all local, state, or national regulations for battery disposal.

## 7 TECHNICAL DATA

### 7.1 LCD Graphic Display

The LCD display is based on the Electronic Assembly EA DOGM132W-5 display module:

- Resolution: 132x32 Pixels
- Viewing Area: 48mm x 13mm
- Text Color: Black
- Background Color: White
- Backlight: Configurable

### 7.2 Analog Signals

Thermocouple Input

Thermocouple Scale: NIST 175, ITS-90

Type K 0-1200°C, reference 0°C: 0 – 48828.0 uV  
 Type S 0-1760°C, reference 0°C: 0 – 18612.38 uV  
 Type R 0-1760°C, reference 0°C: 0 – 21006.36 uV  
 Type B 0-1820°C, reference 0°C: 0 – 13813.50 uV

- Range: 0-100 mV
- Resolution: 20 bit
- Accuracy: 0.02% of FS (at 25°C)
- Full Scale Temperature Coefficient: 10 ppm/°C
- Input Impedance: >100 MΩ
- Cold Junction Compensation: 0.03°C per °C

Thermocouple Type	°F		°C	
	Zero	Span	Zero	Span
<b>B</b>	<b>800</b>	<b>3000</b>	420	1680
K	32	2300	0	1200
R	300	3000	150	1650
S	300	3000	150	1650

**Thermocouple Output:**

- Range: 0-100 mV
- Resolution: 16 bit
- Accuracy: 0.05% of FS (at 25°C)
- Full Scale Temperature Coefficient: 10 ppm/°C
- Max Operating Current: 20mA

**Millivolt Input:**

- Range: 0-2000mV
- Resolution: 20 bit
- Accuracy: 0.02% of FS (at 25°C)



- Full Scale Temperature Coefficient: 10 ppm/°C
- Input Impedance: >100 MΩ

**Millivolt Output:**

- Range: 0-2000Mv
- Resolution: 16 bit
- Accuracy: 0.05% of FS (at 25°C)
- Full Scale Temperature Coefficient: 10 ppm/°C
- Max Operating Current: 20mA

**7.3 General**

Battery Type: 9V NEDA 1604 battery  
 Operating Temperature: 5°C to 55°C  
 Storage Temperature: -20°C to 70°C  
 Dimension: 1" x 3.25" x 6.5"  
 Weight: .45# 1.17# with case (without battery)

**7.4 Standards Conformity**

CE Marked  
 EN 61010-1:2010 Safety Requirements for Electrical Equipment for Measurement, Control, and Laboratory Use.  
 EN 61000-6-2:2008 Electromagnetic compatibility (EMC) - Part 6-2: Generic standards - Immunity for industrial environments  
 EN 61000-6-4:2008+A1:2012 Electromagnetic compatibility (EMC) - Part 6-4: Generic standards - Emission standard for industrial environments  
 EN 50581:2013-03 Technical documentation for the assessment of electrical and electronic products with respect to the restriction of hazardous substances

**8 REFERENCES**

**8.1 Available Cables:**

Sensor Cables				
PB	WW	-XX	-YY	
CABLE LENGTH				
1 METER	01			
2 METER	02			
3 METER	03			
Sensor Type				
	Accucarb	AC		
	Quicksilver	CS		
	Carbonseer	CS		
	Carbonseer-M	CS		

<b>Sensor Cables</b>		
Oxyfire	<b>OX</b>	
NitroCarb	<b>NC</b>	
CS87	<b>NC</b>	
<b>T/C Type</b>		
	No TC	<b>XX</b>
	B	<b>BB</b>
	R/S	<b>RS</b>
	K	<b>KK</b>
Adapter for converting to signal source is included		



Reach us at [www.group-upc.com](http://www.group-upc.com)

United Process Controls brings together leading brands to the heat treating industry including Atmosphere Engineering, Furnace Control, Marathon Monitors and Process-Electronic, and Waukee Engineering. We provide prime control solutions through our worldwide sales and services network with easy-to-access local support.



Americas	Asia	Europe
<p><a href="mailto:support.na@group-upc.com">support.na@group-upc.com</a></p> <p><b>USA:</b> +1 414 462 8200</p> <p><b>Canada:</b> +1 514 335-7191</p>	<p><a href="mailto:service@mmichina.cn">service@mmichina.cn</a></p> <p><b>Shanghai:</b> +86 21 3463 0376</p> <p><b>Beijing:</b> +86 10 8217 6427</p>	<p><a href="mailto:support.eu@group-upc.com">support.eu@group-upc.com</a></p> <p><b>France:</b> +33 3 81 48 37 37</p> <p><b>Germany:</b> +49 7161 94888-0</p> <p><b>Poland:</b> +48 32 296 66 00</p>