

Waukee Flo-Meter

Installation, Operation And Maintenance Manual – revision 3



Manual #: 001

Rev No: 3

Date: 25 March 2013

COPYRIGHT

No part of this publication may be reproduced, transmitted, transcribed, stored in a retrieval system, or translated into any language or computer language, in any form or by any means, electronic, mechanical, magnetic, optical, chemical, manual, or otherwise, without prior written permission of United Process Controls Inc.

DISCLAIMER:

The **Waukee Flo-Meter** is to be used by the industrial operator under his/her direction. Waukee Engineering is not responsible or liable for any product, process, damage or injury incurred while using the **Waukee Flo-Meter**. United Process Controls Inc. makes no representations or warranties with respect to the contents hereof and specifically disclaim any implied warranties or merchantability or fitness for any particular purpose.

For assistance please contact:

United Process Controls Inc.

TEL: +1-414-462-8200 • FAX: +1-414-462-7022

Toll free North America: +1-800-438-3347

waukee.support@group-upc.com

www.group-upc.com

TABLE OF CONTENTS

1. INTRODUCTION	4
2. FLO-METER OVERVIEW	5
3. SPECIFICATIONS.....	6
4. INSTALLATION	7
4.1 <i>M Series Flo-Meter Preparation.....</i>	7
4.2 <i>L Series Flo-Meter Preparation</i>	7
4.3 <i>S Series Flo-Meter Preparation</i>	8
4.4 <i>Piping the Flo-Meter</i>	8
4.5 <i>Recommended Piping</i>	9
4.6 <i>Solenoid Valve Use.....</i>	10
4.7 <i>External Flow Control.....</i>	10
4.8 <i>Flo-Meter Final Assembly.....</i>	10
5. CALIBRATION AND MAINTENANCE.....	11
5.1 <i>Points to Check When Servicing the Flo-Meter.....</i>	11
6. FLO-METER MANUAL CONTROL VALVES.....	12
7. FLO-METER INLET CONDITIONS	13
7.2 <i>Gas Flo-Meter Correction Factor</i>	13
7.3 <i>Liquid Flo-Meter Correction Factor.....</i>	16
8. TROUBLESHOOTING	16
9. APPENDIX “A” - DRAWINGS.....	18
10. Waukee Warranty Policy, Disclaimer and Limitation of Liability.....	19

1. INTRODUCTION

The Purpose of this Manual

Thank you for purchasing a Waukee Flo-Meter. This manual shows you how to install and maintain Waukee Flo-Meter. This manual contains important information and should be read and understood by all individuals who install, use or service this equipment.

Technical Support

We strive to make our manuals the best in the industry. We rely on your feedback to let us know if we are reaching our goal. If you cannot find the solution to your particular application, or, if for any reason you need technical assistance, please call us at:

+1-414-462-8200 Toll free North America: +1-800-438-3347

Our technical support group will work with you to answer your questions. They are available Monday through Friday from 8:00 A.M. to 4:30 P.M. Central Standard Time. We also encourage you to visit our web site where you can find technical and non-technical information about our products and company.

www.group-upc.com

If you have a comment, question or suggestion about any of our products, services, or manuals, please e-mail or contact us by phone.

Conventions Used



When you see the “exclamation point” icon in the left-hand margin, the paragraph to its immediate right will be a warning. This information could prevent injury, loss of property, or even death in extreme cases. Any warning in this manual should be regarded as critical information that should be read in its entirety. The word **WARNING** or **CAUTION** in boldface will mark the beginning of the text.

2. FLO-METER OVERVIEW

The Waukee Flo-Meter is a precision instrument for the indication of rates of flow of air, liquid and industrial gases. Each Flo-Meter is calibrated to the specific specifications of the application as specified when ordered. Meet NFPA requirements for “Visual indication of flow”. Available in a wide range of sizes for almost any gas or liquid, with capacities from 5CFH (.14CMH) to 40,000CFH (1,132CMH)* for gases and 1.5GPH (5.7LPH) to 20GPH (75LPH)*for liquids. Flo-Meters can be panel mounted, and are designed to be trouble free and easily maintained.

*Capacities are based on standard conditions.



WARNING: Flo-Meters that are equipped with a Valve are not designed for positive shut-off. Valves may leak gas into equipment and cause asphyxiation or poisoning to personnel within confined space. If positive shut-off is desired install a mechanical valve prior to the Flo-Meter and verify that it is shut-off prior to servicing equipment attached to the unit.

3. SPECIFICATIONS

Waukee Flo-Meters are available in many different configurations some of the configurations are:

- Add a Standard or Precision manual control valve for manual flow control
- Add a Waukee-Tronic Flow Sensor to send a 4-20mA signal to a Field Device to log the flow
- Add a Electronic Control Valve (Ex. Valve-Tronic-Plus, SAV-Plus, or Ratio-Prover) for automatic flow control
- Add a Flo-Alarm to trigger a high or low flow alarm.
- If you require a set flow rate, add an orifice valve. (Ex. Purge Nitrogen)

Waukee Flo-Meters are designed to operate at a specific temperature, pressure and with a specific gas type. In order to maintain accuracy, the Flo-Meter must be used for the conditions it was calibrated for.

Accuracy:

±3.5% of Reading between 25 and 90% of Full Scale

Max Pressure:

S1 thru S7 - 100psi (689kPa)
 SF1 thru SF7 – 100psi (689kPa)
 M1 thru M11 – 50psi (344kPa)
 L1 thru L6 – 50psi (344kPa)
 L7 thru L10 – 50psi (344kPa)
 MPX1 thru MPX11 – 100psi (689kPa)
 LPX1 thru LPX6 – 100psi (689kPa)
 LPX7 thru LPX10 – 50psi (344kPa)

Inlet/Outlet Connections:

S1 thru S7 – ¼” MNPT
 SF1 thru SF7 – ¼” MNPT
 M1 thru M7 – ¾” FNPT
 M8 thru M11 – 1¼” FNPT
 L1 thru L3 – 1¼” FNPT
 L4 thru L6 – 2” FNPT
 L7 – 3” FNPT
 L8 & L9 – 4” FNPT
 L10 – 5” FNPT

Gas Flo-Meter Materials:

Flo-Meter Components – Aluminum
 Calibration weights – Lead /SS
 Standard Seals – Buna-N
 High Temp Seals - Silicon

Liquid Flo-Meter Materials:

Flo-Meter Components – Brass
 Calibration weights – Brass/SS
 Standard Seals – EP



WARNING: Exceeding the maximum pressure rating may cause the sight glass tube to shatter. Use of a pressure relief valve is required by NFPA guidelines and recommended by Waukee. Failure to advise to this warning may result in damage to the Flo-Meter as well as personal injury.

4. INSTALLATION

The Flo-Meter is shipped as a complete unit. Before installation of the Flo-Meter, inspect it for any signs of shipping damage. Then check the Flo-Meter “Data Plate”, “Scale” and “Gas Tab” to ensure it was built to your specifications.

4.1 M Series Flo-Meter Preparation

Before installation of the Flo-Meter carefully remove the Guard Assembly, to achieve this, lay the Flo-Meter on its back on a work space. Then hold the Guard Assembly with one hand, while unscrewing the Union Nut counterclockwise with the other hand to loosen it. Refer to Figure 1



CAUTION: Once the Guard Assembly is loose from the Flo-Meter make sure to carefully pull the Guard Assembly from the Flo-Meter straight back off the Float Rod Assembly. Moving the Guard Assembly to one side or another during removal may result in damage to the Float Rod Assembly. Inaccurate readings may result if the Float Rod is bent.

Once the Guard Assembly is removed from the Flo-Meter, remove the Float Rod Assembly by grasping onto the Float Stop Body and carefully pulling it straight back out of the Flo-Meter. Verify that the serial number stamped on the Float Rod Assembly matches the serial number on the Flo-Meter. Then store it in a safe location until the Flo-Meter Body is mounted.

4.2 L Series Flo-Meter Preparation

Before installation of the Flo-Meter carefully remove the Guard Assembly, to achieve this, lay the Flo-Meter on its back on a work space. Screw the Hoke Screw clockwise into the Flo-Meter to hold the Float Rod Assembly in place. Then hold the Guard Assembly with one hand, while unscrewing the Union Nut counterclockwise with the other hand to loosen it. Refer to Figure 2.



CAUTION: Once the guard assembly is loose from the Flo-Meter make sure to carefully pull the Guard Assembly from the Flo-Meter straight back off the Float Rod Assembly. Moving the Guard Assembly to one side or another during removal may result in damage to the Float Rod Assembly. Inaccurate readings may result if the Float Rod is bent.

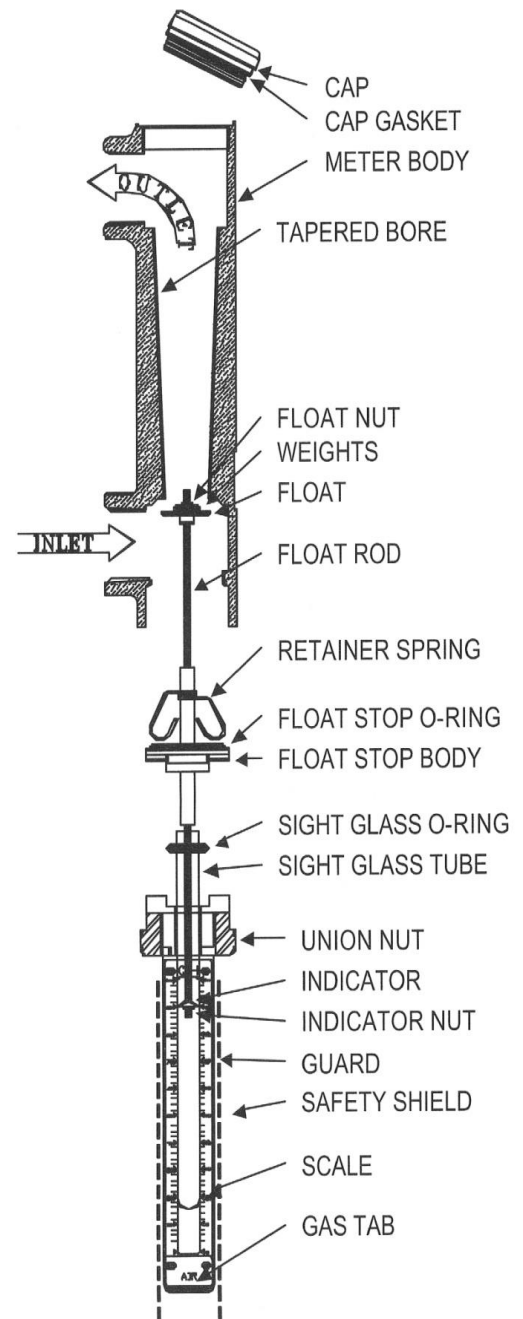

Figure 1

Once the Guard Assembly is removed from the Flo-Meter, remove the Float Rod Assembly by grasping onto the Float Stop Body, then loosen the “Hoke Screw” until the Float Rod Assembly is loose. Carefully pull the Float Rod Assembly straight back out of the Flo-Meter. Verify that the serial number stamped on the Float Rod Assembly matches the serial number on the Flo-Meter. Then store it in a safe location until the Flo-Meter body is mounted.

4.3 S Series Flo-Meter Preparation

Before installation of the Flo-Meter carefully remove the Guard Assembly, to achieve this, lay the Flo-Meter on its side on a work space. Then hold the Guard Assembly with one hand, while unscrewing the Union Nut counterclockwise with the other hand to loosen it. Refer to Figure 3.



CAUTION: Once the Guard Assembly is loose from the Flo-Meter make sure to carefully pull the Guard Assembly and Float Rod Assembly from the Flo-Meter straight back off the Flo-Meter. Moving the Guard Assembly to one side or another during removal may result in damage to the Float Rod Assembly. Inaccurate readings may result if the float rod is bent.

Once the Guard Assembly and Float Rod Assembly are removed from the Flo-Meter, verify that the serial number stamped on the Float Rod Assembly matches the serial number on the Flo-Meter. Then store it in a safe location until the Flo-Meter Body is mounted.

4.4 Piping the Flo-Meter

When piping the Flo-Meter the inlet is at the lower end and the outlet is at the upper end. Use threading compound sparingly as any excess may enter the Flo-Meter and affect its performance. It is important that the Flo-Meter Body be piped absolutely vertical, as deviation may cause errors in flow indication. If possible, install a pressure tap at the inlet of the Flo-Meter for easy verification of correct inlet pressure. See Figure 4 for recommended piping.



WARNING: Flo-Meter must be earth grounded. Ungrounded Flo-Meters may become a source of ignition.

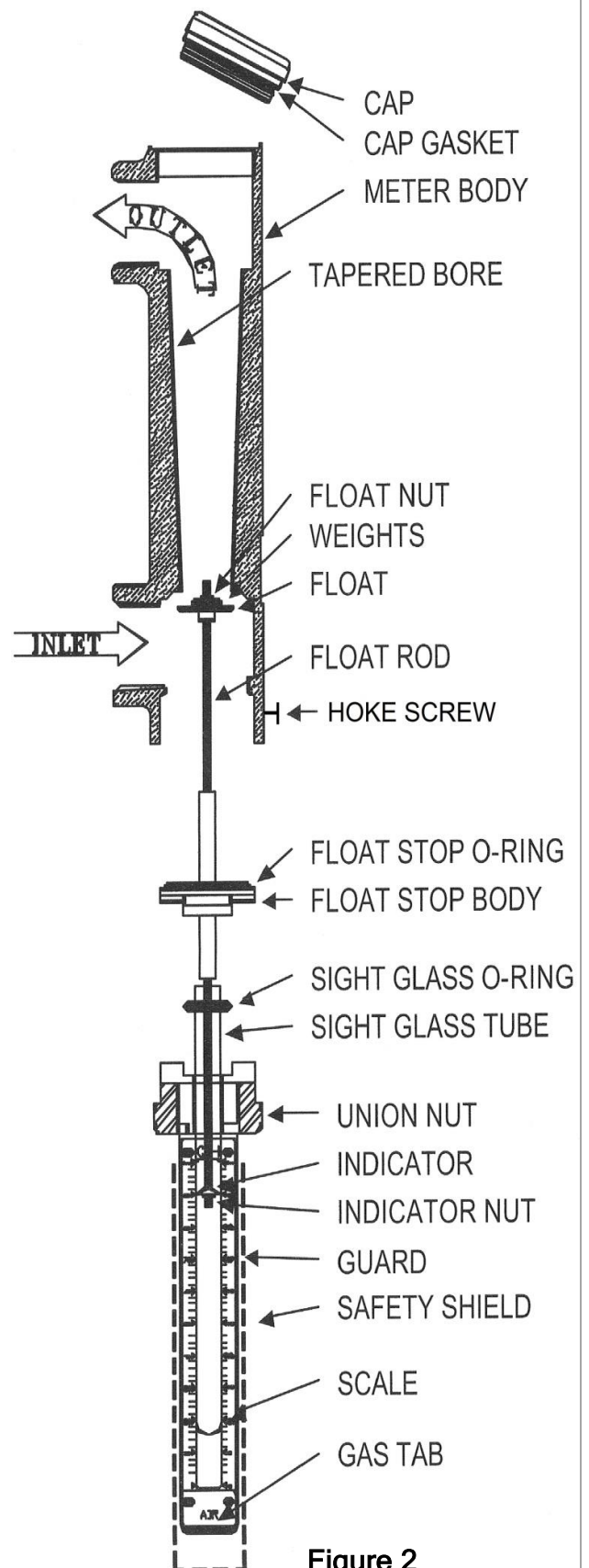

Figure 2

4.5 Recommended Piping

Waukee recommends piping the Flo-Meter as shown below in Figure 4. The first regulator is only required if the supply pressure from the tank is higher than 100psi. The next regulator should be located prior to the inlet of the Flo-Meter and set to the pressure the Flo-Meter is calibrated for. A pressure relief valve should be installed in-between the final regulator and Flo-Meter and set to a pressure of 20% or less than the maximum rated pressure of the Flo-Meter. The pressure relief valve protects the Flo-Meter in the event of over pressurization and is required per NFPA guidelines. Manual lockable ball valves should be located at the inlet and outlet of the Flo-Meter. The ball valves serve two purposes. They provide positive shut-off for service of equipment that the Flo-Meter is connected to, and also provides a shut-off for easy replacement of the Flo-Meter if ever required. The unions on the Inlet and Outlet of the Flo-Meter are not required, but provide an easy and convenient way to swap the Flo-Meter out with another Flo-Meter if needed.



CAUTION: If the supply fluid is a high pressure supply, greater than 100 psi (689kPa). It is extremely important to use two pressure regulators. The first regulator should step the pressure down to about double of the final pressure to the Flo-Meter and the final regulator should be set to the calibration pressure of the Flo-Meter. This will protect the Flo-Meter from high pressure fluid in the event that a regulator was to fail.

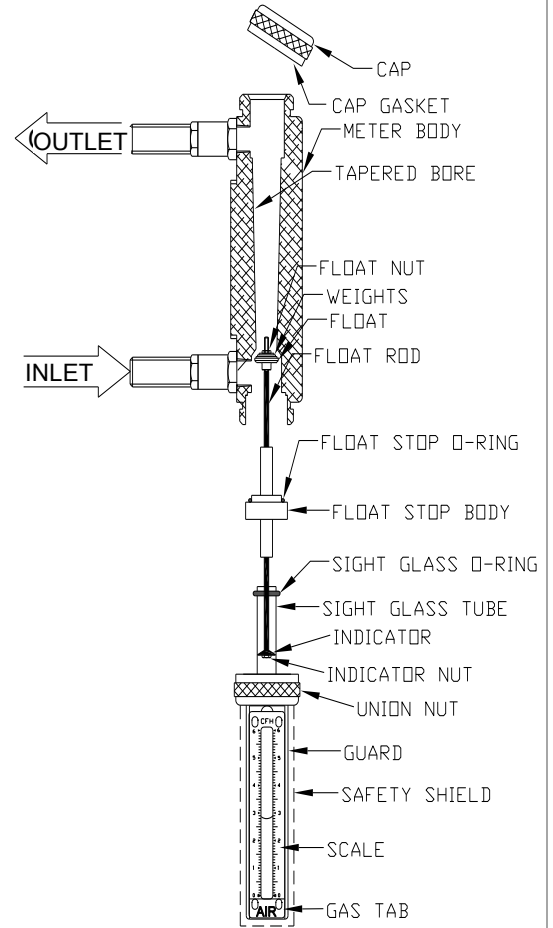

Figure 3

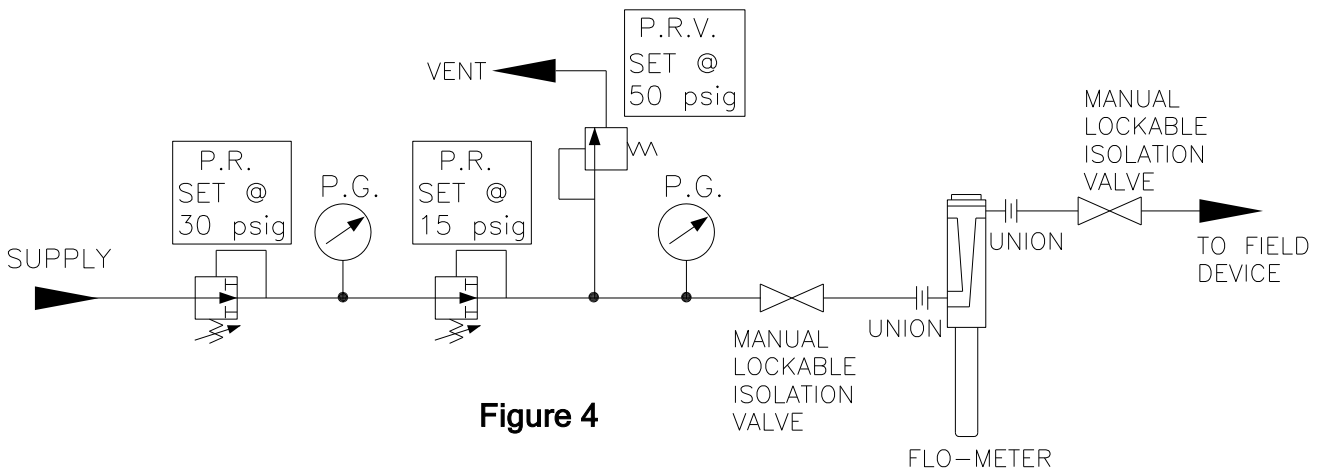

Figure 4

4.6 Solenoid Valve Use

If your application requires the use of a solenoid valve for flow control it is recommended to only use Float Rod Assemblies designed to absorb the shock from the pressure spike caused by solenoid valves. When ordering a Flo-Meter for use with a solenoid valve, make sure to order it with a “Buffer Spring” The buffer spring absorbs the shock due to spiking caused by solenoid valves and prologs the life of the Float Rod Assembly. Figure 5 shows a Float Rod Assembly with a buffer spring.

4.7 External Flow Control

If your application requires the use of an external flow control valve (Ex. Butterfly Valve, Orifice) it should be located on the outlet of the Flo-Meter. Installing the valve prior to the Flo-Meter will result in inaccuracies in the Flo-Meter readings.

4.8 Flo-Meter Final Assembly

Once the Flo-Meter is mounted, remove the red tape from the Float Rod. Insert the Float Rod Assembly into the Flo-Meter by pulling the float upwards about 3” holding it in this position by grasping the float rod and the bottom of the “Float Stop Body” simultaneously as shown in Figure 6 for M & L Series and Figure 7 for S series. Carefully guide the float rod into the bore of the Flo-Meter. Before releasing your grasp of the float rod assembly, ensure that the it is held in place with either the retaining spring (M series Flo-Meters) or with the Hoke Screw (L series Flo-Meters) or with Guard Assembly (S series) Remove the Sight Glass Tube from the Guard Assembly and fill the tube with Waukee Flo-Meter Oil so that the level of oil is approximately one (1) inch from the top. **Note:** Do not put oil in the Sight Glass Tube of meters used for **oxygen** or **liquid** service. Oxygen Flo-Meters should be run dry, or with distilled water. Flo-Meters for liquid service will automatically fill the sight glass tube with liquid when in service. Place the Sight Glass Tube back into the Guard Assembly, making sure the Sight Glass Tube O-ring is properly seated, and then carefully install the Guard Assembly on to the Flo-Meter.

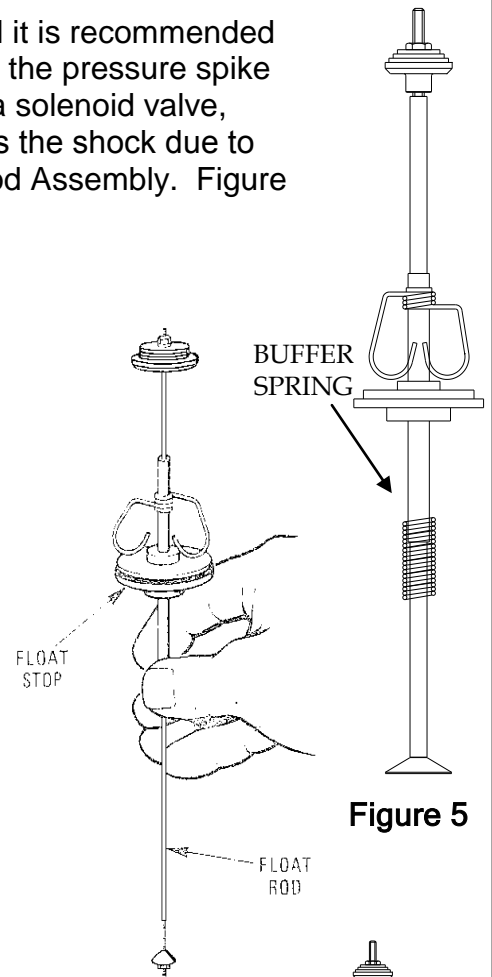

Figure 5

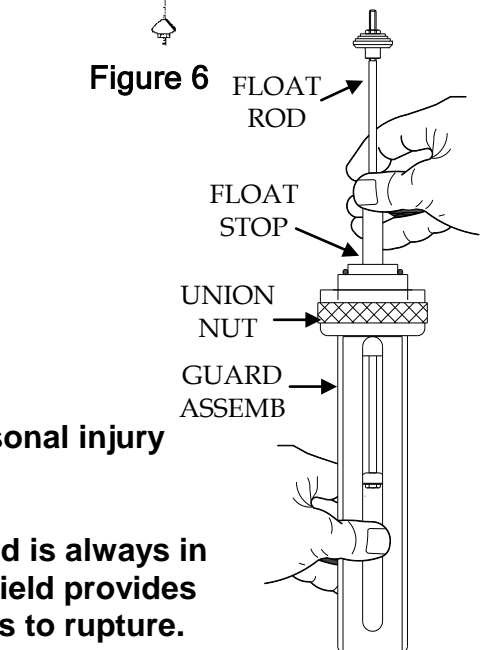

Figure 6

Figure 7



WARNING: Do not fill the Sight Glass Tube with Flo-Meter oil on meters used for Oxygen service. Use of oil may cause fire or explosion. Serious personal injury may result from fire or explosion.



WARNING: Be sure clear polycarbonate Safety Shield is always in place when Flo-Meter is in operation. The Safety Shield provides protection in the event that the Sight Glass Tube was to rupture. Severe injury may result to personnel if Safety Shield is not in place.

5. CALIBRATION AND MAINTENANCE

Waukee Flo-Meters are calibrated in our ISO/IEC 17025:2005 accredited laboratory and are traceable to NIST (National Institute of Standards and Technology). Waukee recommends having the Flo-Meters calibrated annually. The Flo-Meters can be either sent back to the factory for re-calibration or a field service technician can visit your facilities and calibrate the Flo-Meters in the field. For additional information regarding our calibration services, please contact Waukee.

Waukee Flo-Meters are designed for fast and easy maintenance. Maintenance intervals are depended on the cleanliness of the gas and the application. For example a Flo-Meter used for Endothermic gas service will require more maintenance intervals then a Flo-Meter for Nitrogen service. It is recommended that you setup a maintenance program within your organization for when to service each Flo-Meter in your facility. The Flo-Meter's performance will degrade if it is not properly maintained and will result in inaccurate flow readings.

5.1 Points to Check When Servicing the Flo-Meter

The following will require removal of the Float Rod Assembly, for removal and installation of the Float Rod Assembly refer to the "Installation" section of this manual. Also refer to the "Installation" section for location of components. Ensure Supply gas is turned off before performing any service work on any Flo-Meters.

- Are the Pressure, Temperature and Specific Gravity (Gas Type) being used the same as what the Flo-Meter is calibrated for? This information can be found on the Serial Plate located on the front of the Flo-Meter. (See Figure 8) Pressure is very critical to the accuracy of the Flo-Meter, for every 1psi (6.9kPa) from calibrated pressure will result in about a 3% inaccuracy in reading. The temperature will also have a slight effect on the accuracy of the Flo-Meter, for every 10° of deviation from the calibrated temperature will result in about a 1% inaccuracy. Using a different gas type then what the Flo-Meter was calibrated for may result in huge inaccuracies, depending on what the Flo-Meter is calibrated for and what gas type is currently flowing through the Flo-Meter. If any of these values deviate from what the Flo-Meter is calibrated for, you can use a correction factor to find out the actual flow rate for a given indicated flow rate. Use the Correction factor formula located in this manual.

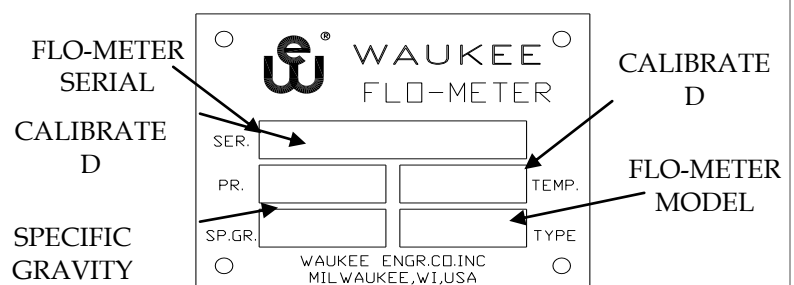

Figure 8

- Does the serial number on the Flo-Meter match the number stamped on the Float Stop Body? Each Flo-Meter is matched with a Float Rod Assembly. No two Flo-Meters are the same, even if both Flo-Meters are calibrated for the same specifications. The serial numbers must match in order for accurate flow measurement.

3. Is the Bore of the Flo-Meter Clean? If not, use a mild detergent or degreaser and nylon bore brush and carefully clean the bore of the Flo-Meter. Dirt and foreign material inside the Flo-Meter may cause poor performance and inaccuracies in flow readings.
4. Is the Float Rod Assembly Clean? If not, use a mild detergent or degreaser and a rag and carefully clean the Float Rod Assembly. Be very careful not to bend the Float Rod when cleaning the Float Rod Assembly. Bending the Float Rod will result in poor performance and inaccurate readings.
5. Are the Calibration Weights securely fastened to the top of the Float Rod and are they flat with respect to the top of the float? If not this could be the sign of the Flo-Meter being “Spiked”, and a new Float Rod Assembly should be ordered. If the Flo-Meter is being controlled by a solenoid valve resulting in “spiking” the Flo-Meter to full flow, make sure to order your replacement Float Rod Assembly with a “Buffer Spring”. The buffer spring will absorb the “Shock” due to spiking and prolong the life of the Float Rod Assembly.
6. Is the Float Rod straight? Rotate the float rod to determine if it is straight, bent Float Rods may result in undesirable operation and inaccuracies in flow reading. If the Float Rod is bent it is recommended to replace it with a new one.
7. Is Float Rod Stop Tube straight and perpendicular with Float Stop Body? If not, order a replacement Float Rod Assembly. Bent Float Rod Stop Tubes may cause poor performance and inaccurate readings.
8. Is the Flo-Meter mounted plumb? If not, re-pipe the Flo-Meter to make it plumb. If the Flo-Meter is not plumb, it could result in inaccuracies in flow measurement.
9. Are Seals and Gaskets in good condition? Inspect all seals and gaskets for cracks, tears, brittleness or abrasions. Order a gasket kit and replace all seals if any are bad.
10. Inspect Sight Glass Tube for any cracks or chips and replace if any are found.
11. Is Flo-Meter Oil Dirty? If so, replace with new Waukee Flo-Meter oil. Use Only Waukee Flo-Meter Oil, other oils may result in inaccuracies in the Flo-Meter readings.

6. FLO-METER MANUAL CONTROL VALVES

Waukee Flo-Meters are available with two types of manual control valves. Precision Manual Control Valves (Needle and Orifice) and Standard Manual Control Valves (Nylon Cone Nose) Precision valves provide precise control for liquids and gases and are designed to be used for a specific flow rate, while Standard Valves are not flow rate specific and are a more course flow control valve. The Valves are designed to be robust and require little maintenance.

7. FLO-METER INLET CONDITIONS

Waukee Flo-Meters are calibrated for use with a specific gas, temperature and pressure, deviation from any of the Flo-Meters calibrated parameters will result in inaccuracies in flow readings. If you need to use the Flo-Meter with different inlet conditions, it is recommended to either send the Flo-Meter back to Waukee to re-calibrate the Flo-Meter to the new inlet conditions or purchases a new Flo-Meter for the new inlet conditions. Note: Depending on how much the inlet conditions are changed, the Flo-Meter may not be recalibrated due to the Flo-Meter may not have the capacity to flow at the new inlet conditions and will require a new Flo-Meter. Before changing any Flo-Meter usage, be sure to consult with Waukee. Provide the serial number of the Flo-Meter you intent to change the inlet conditions along with what you are changing. Waukee will need this information to verify the propriety of your intended usage and the resultant calculations if you intend to use the Flo-Meter for any conditions other than those specified on the serial plate (Gas Type, Pressure, and Temperature).



CAUTION: Serious hazards can result by changing the usage. The Sight Glass Tube may break or leak at higher pressures and temperatures or internal components may corrode from the gas being used.

Flo-Meters for gas are not greatly affected by changes in temperature, but changes in gas type and especially pressure changes will greatly affect the accuracy of the Flo-Meter. Waukee has provided a correction factor for these changes. Refer to Gas Flo-Meter Correction Factor below.

Flo-Meters for liquids are not affected by pressure changes, but are affected by liquid type and especially temperature. Temperature changes the viscosity of the liquid and in turn affects the reading of the Flo-Meter. Refer to “Liquid Flo-Meter Correction Factor”.

7.2 Gas Flo-Meter Correction Factor

FORMULA:
$$SF = \sqrt{\frac{SG1}{SG2} \times \frac{T1}{T2} \times \frac{P2}{P1}}$$
 \Rightarrow $SF \times SR = AF$

Terms

SG1 = Specific Gravity of gas the Flo-Meter is calibrated for
 SG2 = Specific Gravity of the gas to be used in the Flo-Meter
 T1 = Absolute Temperature of gas the Flo-Meter is calibrated for
 T2 = Absolute Temperature of gas to be used in the Flo-Meter
 P1 = Absolute Pressure of gas the Flo-Meter is calibrated for
 P2 = Absolute Pressure of gas to be used in the Flo-Meter
 SF = Scale Factor
 SR = Scale Flow Reading
 AF = Actual Flow Rate

Conversion of Temperature to Absolute

Absolute Temperature = 460 + Nameplate Temperature in °F

Or

Absolute Temperature = 273 + Nameplate Temperature in °C

Conversion of Pressure to Absolute

Absolute Pressure = 14.7 + Nameplate Pressure in psi

Or

Absolute Pressure = 101.4 + Nameplate Pressure in kPa

Example 1

The supply pressure to the Flo-Meter is 5 psig and the Flo-Meter is calibrated for 1 psig and indicates a flow of 200 CFH.

1. Start by converting the Pressures to Absolute

$$P2 = 5 + 14.7 = 19.7$$

$$P1 = 1 + 14.7 = 15.7$$

2. Use the following values to calculate the Scale Factor (SF)

$$\sqrt{\frac{19.7}{15.7}} = 1.12$$

3. Multiply the scale reading of the Flo-Meter by the Scale Factor (SF)
 $200 \times 1.12 = 224$
 224 CFH is the actual flow, flowing thru the Flo-Meter at the new pressure.

Example 2

The supply pressure to the Flo-Meter is 34.5 kPa and the Flo-Meter is calibrated for 6.9 kPa and indicates a flow of 200 CFH.

1. Start by converting the Pressures to Absolute

$$P2 = 34.5 + 101.4 = 135.9$$

$$P1 = 6.9 + 101.4 = 108.3$$

2. Use the following values to calculate the Scale Factor (SF)

$$\sqrt{\frac{135.9}{108.3}} = 1.12$$

3. Multiply the scale reading of the Flo-Meter by the Scale Factor (SF)
 $200 \times 1.12 = 224$
 224 CFH is the actual flow, flowing thru the Flo-Meter at the new pressure.

Example 3

The supply gas temperature is 90°F and the Flo-Meter is calibrated for 70°F and indicates a flow of 200 CFH.

1. Start by converting the Pressures to Absolute

$$T2 = 460 + 90 = 550$$

$$T1 = 460 + 70 = 530$$

2. Use the following values to calculate the Scale Factor (SF)

$$\sqrt{\frac{530}{550}} = .98$$

3. Multiply the scale reading of the Flo-Meter by the Scale Factor (SF)
 $200 \times .98 = 196$
 196 CFH is the actual flow, flowing thru the Flo-Meter at the new Temperature.

Example 4

The supply gas temperature is 90°F and the Flo-Meter is calibrated for 70°F and indicates a flow of 200 CFH.

1. Start by converting the Pressures to Absolute

$$T2 = 273 + 32 = 305$$

$$T1 = 273 + 21 = 294$$

2. Use the following values to calculate the Scale Factor (SF)

$$\sqrt{\frac{294}{305}} = .98$$

3. Multiply the scale reading of the Flo-Meter by the Scale Factor (SF)
 $200 \times .98 = 196$
 196 CFH is the actual flow, flowing thru the Flo-Meter at the new Temperature.

7.3 Liquid Flo-Meter Correction Factor

Formula: $SF = \frac{VC}{NV} \implies SM \times SR = AF$

Terms

- SF = Scale Factor
- VC = Viscosity of Liquid at Flo-Meter calibrated temperature
- NV = Viscosity of Liquid at new temperature
- SR = Scale Flow Reading
- AF = Actual Flow Rate

Table 1 to the right shows the viscosity of Methanol at different temperatures. If the liquid you are using is not Methanol you will need to look-up the viscosity of the liquid you are using for the specific temperature as required by the above formula

Temperature	Viscosity (Centipoises)
20°F (-6.7°C)	0.9472
25°F (-3.9°C)	0.8948
30°F (-1.1°C)	0.8424
35°F (1.7°C)	0.7995
40°F (4.4°C)	0.7630
45°F (7.2°C)	0.7266
50°F (10.0°C)	0.6901
55°F (12.8°C)	0.6638
60°F (15.6°C)	0.6376
65°F (18.3°C)	0.6114
70°F (21.1°C)	0.5873
75°F (23.9°C)	0.5664
80°F (26.7°C)	0.5455
85°F (29.4°C)	0.5246
90°F (32.2°C)	0.5062

Table 1

Example 1

The supply methanol temperature is 90°F and the Flo-Meter is calibrated for 70°F and indicates a flow of 1 GPH.

1. Start by looking at Table 1 to find the viscosities of Methanol
 $VC = .5803$
 $NV = .5062$
2. Use the following values to calculate the Scale Factor (SF)

$$\frac{.5803}{.5062} = 1.146$$

3. Multiply the scale reading of the Flo-Meter by the Scale Factor (SF)
 $1 \times 1.146 = 1.146$
 1.146 GPH is the actual flow, flowing thru the Flo-Meter at the new Temperature.

8. TROUBLESHOOTING

PROBLEM	SYMPTOMS	PROBABLE CAUSE	RECOMMENDED ACTION
No Flow	Flo-Meter indicates Zero Flow	Solenoid Valve Closed Service Valve Closed Manual Control Valve Closed Float Stuck at Zero Flow Not enough supply pressure Plugged Limiting Orifice Valve or plumbing	Check Solenoid Valve Open any service valves Open Manual Control Valve Perform Maintenance on Flo-Meter Check Pressure Regulator Check all Plumbing for any clogging or plugs
Manual Valve does not adjust Flow	Turning the Valve clockwise or counterclockwise does not change the flow rate	Retaining screw on Control Knob is loose	Make sure Retaining Screw is aligned with flat on Valve Stem and tighten into place
Gas Leaking from Flo-Meter	Gas leakage	Loose connections or bad seals	Locate source of leak, If leak is at the inlet or outlet connections, remove pipe and apply sealing compound and re-install. If the leak is located on the top or bottom of the Flo-meter then hand tighten all fittings, if leak persists replace all seals in Flo-Meter.

9. APPENDIX “A” - DRAWINGS

On request

10. Waukee Warranty Policy, Disclaimer and Limitation of Liability

EXPRESS WARRANTY ON WAUKEE EQUIPMENT

WAUKEE warrants its products for a period of one (1) year from date of shipment from WAUKEE to the original purchaser to be free from defects in material and workmanship under normal recommended use, service, inspection and maintenance. Normal recommended use, service inspection and maintenance mean:

1. Not to be used in excess of nor below the rated capacity, pressures and temperature ranges specified in the applicable quotation, purchase order, acknowledgment, marketing literature, nameplate(s), specification sheet or the Installation, Operation, Inspection and Maintenance Manual (THE MANUAL);
2. Using only clean liquids or gases (only liquids in liquid Flo-Meters and only gases in gas Flo-Meters); air and fuel gases used in mixing equipment to be clean and free of solids all as further explained in THE MANUAL; and
3. Installation, operation, inspection and maintenance in compliance with THE MANUAL; and
4. The WAUKEE products being used only in:
 - a) Ambient environments lower than 132° Fahrenheit (54° Celsius) unless specifically designed and so labeled by WAUKEE for higher temperatures; and
 - b) Non-corrosive environments; and
 - c) Completely protected from moisture, rain, snow or other outside environments; and
 - d) Not to be used below 32° Fahrenheit (0° Celsius) unless special precautions are taken for low temperature conditions as shown in THE MANUAL
5. Being used only for applications permitted by THE MANUAL or other WAUKEE literature or special applications approved in a separate written authorization by WAUKEE

WARRANTY EXCEPTIONS

This Warranty does not apply to damage caused by any or all of the following circumstances or conditions:

1. Freight damage;
2. Parts, accessories, materials or components not obtained from nor approved in writing by WAUKEE;
3. Any consequential or incidental damages including but not limited to loss of use, loss of profits, loss of sales, increased costs, arising from the use of any product, system or other goods or services manufactured, sold or provided by WAUKEE;
4. Misapplication, misuse and failure to follow THE MANUAL or other literature, instructions or bulletins (including drawings) published or distributed prior to THE MANUAL

The exclusive remedy under this Warranty or any other express warranty is the repair or replacement without charge for labor and materials of any WAUKEE parts found upon examination by WAUKEE to have been defective. Since certain WAUKEE equipment is heavy, bulky and not deliverable by U.S. mail or other parcel

service, WAUKEE equipment may be returned only upon written consent of WAUKEE and then only to the location designated by WAUKEE. Generally such consent will be given only upon the condition that the customer assume and prepay all carrier charges and responsibility for damage in transit. Purchasers of WAUKEE products, equipment, goods or services waive subrogation on all items covered under their own or any other insurance.

DISCLAIMER

THIS WARRANTY IS EXCLUSIVE. WAUKEE EXPRESSLY DISCLAIMS ANY AND ALL OTHER WARRANTIES WHETHER EXPRESS OR IMPLIED INCLUDING ANY IMPLIED WARRANTY OF MERCHANTABILITY OR FITNESS FOR A PARTICULAR PURPOSE OR ANY PURPOSE.

No person, including any dealer, seller or other representative of WAUKEE is authorized to make, on behalf of WAUKEE, any representations beyond those contained in WAUKEE literature and documents or to assume for WAUKEE any obligations or duties not contained in this Warranty and Warranty Policy.

WAUKEE reserves the right to make design and other changes, modifications or improvements to its products, services, literature or systems, without any obligation, to furnish or install same on any previously sold or delivered products or systems.

LIMITATION OF LIABILITY

It is expressly agreed that the liability of WAUKEE is limited and WAUKEE does not function as an insurer. The purchaser and/or user agree that WAUKEE is not liable for loss, harm or damage due directly or indirectly to any occurrence or consequences there from. If WAUKEE should be found liable to anyone on any theory (except any express warranty where the remedy is set forth in Section 2 of this Warranty and Warranty Policy) for loss, harm or damage, the liability of WAUKEE shall be limited to the lesser of the actual loss, harm or damage or the purchase price of the involved WAUKEE equipment or service when sold (or when service performed) by WAUKEE to its customer. This liability is exclusive and regardless of cause or origin resulting directly or indirectly to any person or property from:

1. The performance or nonperformance of any obligations set forth in this Warranty and Warranty Policy;
2. 2 Any agreement including specifications between WAUKEE and the customer;
3. 3 Negligence, active, passive or otherwise of WAUKEE or any of its agents or employees;
4. Breach of any judicially imposed warranty or covenant of workmanship, durability or performance; and
5. Misrepresentation (under the Restatement, common law or otherwise) and/or strict liability involvement
6. Liability for fraud-in-the-inducement

INFORMATION NECESSARY TO OBTAIN TECHNICAL ASSISTANCE

For WAUKEE to appropriately respond to a request for assistance or evaluation of customer or user operating difficulty please provide at a minimum the following information:

1. Serial number and type or model of meter, compressor or other equipment and all other data shown on the nameplate and on the specific component which appears to be involved in the difficulty;
2. The date and from whom you purchased your WAUKEE equipment and your purchase order number

3. State your difficulty, being sure to mention at least the following:
4. Application
5. Input pressure where Flo-Meters or compressors are involved
6. Condition of filters, strainers or screens, upstream or downstream of the WAUKEE equipment
7. Gas or liquid temperatures and other ambient conditions at the time of the difficulty
8. Type of lubrication being used (if any) - give specifics
9. Any other relevant pressures including gauge readings both upstream and downstream of the WAUKEE equipment.
10. All electrical information available.
11. Performance activity.
12. Any other pertinent information. If a sketch would help explain the difficulty, please include one.

WARRANTY FIELD SERVICE

If warranty Field Service at the request of the purchaser or user is rendered and the difficulty is found not to be with WAUKEE's product, the purchaser shall pay the time and expense (at the prevailing rate at the time of the service) of WAUKEE's field representative(s). Charges for service, labor and other expenses that have been incurred by the purchaser, its customer or agent without written approval of WAUKEE will not be accepted. The OEM or other reseller is responsible for transmitting installation and operating instructions, THE MANUAL or other service literature supplied by WAUKEE with the equipment.

Reach us at www.group-upc.com

United Process Controls brings together leading brands to the heat treating industry including Waukee Engineering, Furnace Control, Marathon Monitors and Process-Electronic.

We provide prime control solutions through our worldwide sales and services network with easy-to-access local support.

UNITED PROCESS CONTROLS INC.
WAUKEE PRODUCTS PLANT
5600 West Florist Avenue, Milwaukee, WI 53218, U.S.A.

Phone: +1-414-462-8200 Fax: +1-414-462-7022
E-mail: waukee.sales@group-upc.com

