

## WHAT IS NITREG®-S

Stainless steels respond to nitriding differently than other ferrous alloys, and there are also significant differences within the stainless group as well. The primary reason for this is that depending on the chemistry of the steel it will behave differently with respect to the kinetics of layer formation, and it is a rather difficult process to control. In other words, unless you know what you are doing you may end up with nothing, or too little, or too much case depth or white layer, or even damaged parts.

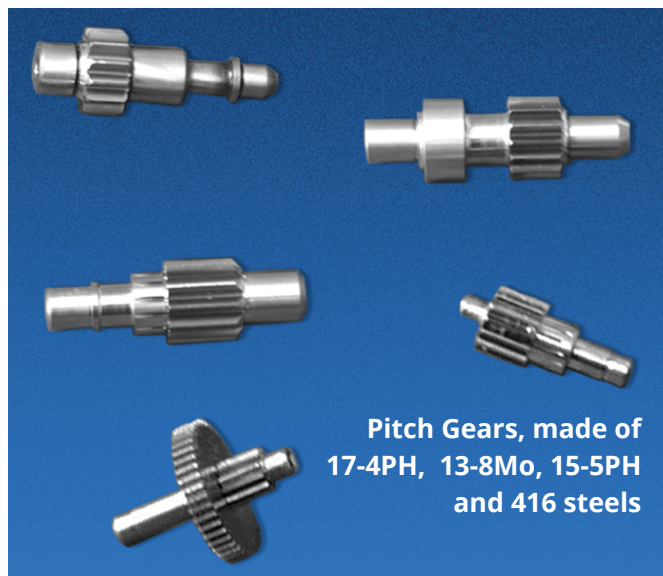

**NITREG®-S** is a process in which any stainless steel may be nitrided, with complete control over the formation of nitrided layers.

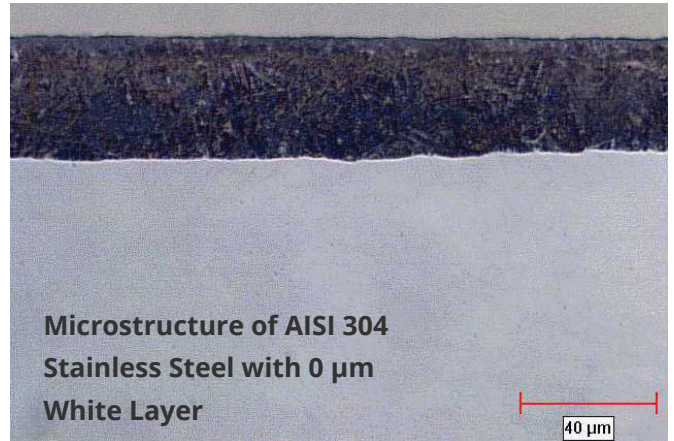

## NITREG®-S ADVANTAGE

- Attains excellent wear resistance
- Improves fatigue strength
- Prevents galling
- Does not alter chemical composition of alloy
- Has no effect on the steel's non-magnetic nature
- No change in the color, shape or size
- Uniformly hardened even small bores, tight grooves and sharp edges
- Green technology, no waste pollution

## HOW IS IT CONTROLLED?

With **NITREG®-S** the following aspects of the process are controlled:

- diffusion is the same as in any other well run, high quality nitriding process – it is a function of temperature and time in a suitable atmosphere
- ability to produce a diffusion case with zero white layer, or a layer of specific thickness
- the process is controlled primarily through:
  - proper sequence of stages
  - gas mixtures in individual stages of the process
  - temperatures
  - nitriding potential for control of the white layer formation

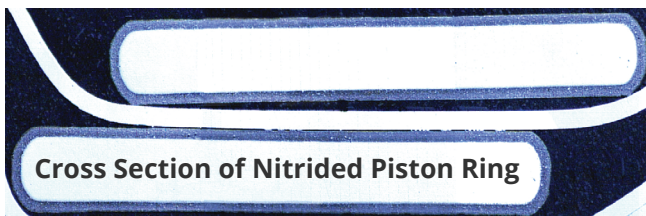
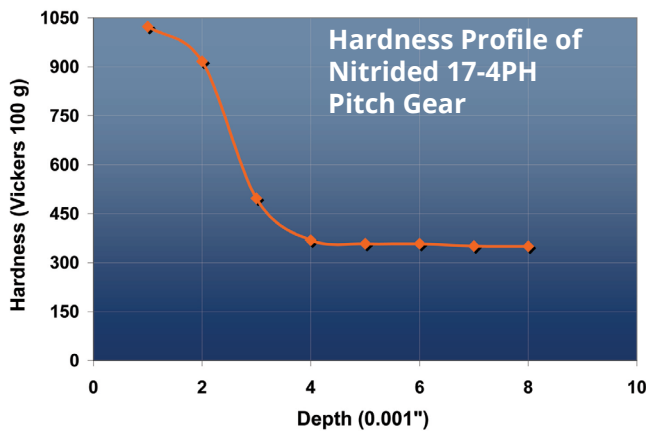

## RESULTS

The most significant characteristic of the Nitreg® family of nitriding technologies is our ability to control the development of the diffusion case separately from the compound (white) layer.

Some find it hard to believe, but we are able to produce any case depth combined with any white layer thickness, within the ranges described below. In nitriding of stainless steel it is extremely important to understand the risks in specifying a deep case or a thick compound layer. Stainless steels develop extremely hard nitrided layers, due to their alloy content, primarily chromium. Therefore a reasonable specification will rarely exceed a 0.006" (150 µm) case, and the white layer should generally be within the zero to 0.0004" (10 µm) range. Should these be exceeded, there is risk of damage due to the layer's inherent brittleness.

Users must also understand that nitriding may produce some loss of corrosion resistance. We have developed methods of minimizing the effect, an important issue in certain applications.

### Treatable Materials

- 303
- 422
- 17-4PH
- 13-8Mo
- A286
- High Nickel Alloys
- Inquire about other materials

### Typical Applications

- Actuator Components
- Gears, Gear-shafts
- Latches, Levers, Locks
- Pins, Plates
- Racks and Pinions
- Valve Stems
- And Many Others

### CANADA / USA

+1 514 335 7191  
nitrex@nitrex.com

### POLAND

+48 32 296 66 30  
nitrex.europe@nitrex.com

### CHINA

+86 (0) 10 6257 3050  
nitrex.china@nitrex.com

